

HANDBOOK



PARTNER Tepee





On-line handbook

Select one of the following means of access to view your handbook on-line...

Find your handbook on the PEUGEOT website, under "MyPEUGEOT".

This personal space offers advice and other useful information for the care and maintenance of your vehicle.

Scan this code for direct access to your handbook.



 If the "MyPEUGEOT" function is not available on the PEUGEOT public website for your country, you can find your handbook at the following address:

<http://public.servicebox.peugeot.com/ddb/>

Select:

- > the language,
- > the vehicle, its body style,
- > the print edition of your handbook appropriate for the date of registration of your vehicle.

Referring to the handbook on-line also gives you access to the latest information available, easily identified by the bookmark, associated with this symbol:





PEUGEOT

This handbook has been designed to help you make the most of your Partner in all circumstances and in complete safety.

Take the time to read through it so as to familiarise yourself with your vehicle.

This handbook covers all of the variations in equipment available across the whole Partner range. Your vehicle will be fitted with only some of the equipment described in this document, depending on its trim level, version and the specification for the country in which it was sold.

The descriptions and illustrations are given as indications only.

Automobiles PEUGEOT reserves the right to modify the technical characteristics, equipment and accessories without having to update this edition of the handbook.

This document forms an integral part of your vehicle. Remember to pass it on to the new owner in the event of the sale of the vehicle.

Welcome

Thank you for choosing this vehicle.

This handbook has been designed to enable you to make the most of your vehicle in all situations.

Key



safety warning



additional information



contributes to the protection of the environment

Contents

2

1. OVERVIEW		3. READY TO GO		4. EASE OF USE and COMFORT		5. SAFETY	
4-14		18-57		58-112		113-147	
Exterior	5	Key	18	Lighting	58	General safety recommendations	113
Interior	6	Alarm	20	Wipers	61	Hazard warning lamps	114
left hand drive	6	Doors	21	Trip computer	63	Horn	114
right hand drive	7	Tailgate	23	Cruise control	64	Parking brake	114
Instruments and controls	8	Rear roof flap	26	Speed limiter	67	Parking sensors	115
left hand drive	8	Central locking	27	Heating / Air conditioning		Reversing camera	117
right hand drive	10	Instrument panel	28	manual	70	Anti-lock braking system (ABS)	118
Technical data - Maintenance	12	Date and time	29	digital	72	EBA	118
		Warning lamps	32	Demisting and defrosting	75	ASR and DSC	119
		Fuel gauge	40	Front seats	77	Grip control	120
		Coolant	40	Rear bench seat	79	Active City Brake	122
		Under-inflation detection	41	Rear seats (5 seat version)	82	Seat belts	126
		Under-inflation detection with reinitialisation	43	Rear seats (7 seat version)	85	Airbags	129
		Service indicator	47	Modularity	92	Carrying children	133
		Lighting dimmer	48	Front fittings	94	Deactivating the passenger's front airbag	136
		Steering wheel adjustment	49	Zenith roof	97	Recommended seats	139
		Manual gearbox	49	Roof bars	102	Installation	141
		Gear shift indicator	50	Courtesy lamps	103	ISOFIX mountings	143
		6-speed electronic gearbox	51	Load space cover (5 seat version)	104	Recommended ISOFIX seat	144
		Stop & Start	53	Load space cover (7 seat version)	108	ISOFIX locations	145
		Starting and stopping	55	Mirrors	110	Child lock	147
		Hill start assist	56	Electric windows	112		
		Driving recommendations	57				
2. ECO-DRIVING							
15-17							
Environment	15						
Eco-driving	16						

6. ACCESSORIES**148-152**

Towing a trailer	148
Towbar with detachable swan neck towball	150
Other accessories	152

8. QUICK HELP**170-192**

Battery	170
Temporary puncture repair kit	172
Changing a wheel	173
Removable snow screen	179
Snow chains	180
Changing a bulb a fuse	181 187
a wiper blade	191
Being towed	192

**10. TECHNOLOGY
on BOARD****203-282**

7-inch touch screen	203
PEUGEOT Connect Sound (RD5)	265

The "Technology on board" section presents the new audio/navigation systems.

PEUGEOT Connect is the name given to all of the new equipment of the radio/navigation range.

7. CHECKS**153-169**

Opening the bonnet	154
Petrol engine	155
Diesel engine	156
Levels	157
Checks	159
Fuel	161
Fuel cut-off	163
Diesel priming pump	163
BlueHDi and AdBlue	164

**9. TECHNICAL
DATA****193-201**

Dimensions	193
Engines	197
Weights	197
Identification markings	201



Corresponds to a left hand drive vehicle.



Corresponds to a right hand drive vehicle.

INTRODUCTION



4



For any work on your vehicle, use a qualified workshop that has the technical information, skills and equipment required, all of which a PEUGEOT dealer is able to provide.

The equipment presented may be standard, an option or not available, depending on the model and can vary from one country to another or not be available in all countries of sale.

Within each section, symbols draw your attention to specific information:

-  directs you to the section and part which contains detailed information concerning a function,
-  indicates important information relating to use of the equipment,
-  alerts you to the safety of individuals and on-board equipment.

EXTERIOR

		<table border="0"> <tr> <td style="padding-right: 20px;">Dimensions</td> <td>193-196</td> </tr> </table>	Dimensions	193-196																																	
Dimensions	193-196																																				
<table border="0"> <tr> <td style="padding-right: 20px;">Accessories</td> <td>152</td> </tr> </table>	Accessories	152			<table border="0"> <tr> <td style="padding-right: 20px;">Remote control</td> <td>18-19</td> </tr> <tr> <td style="padding-right: 20px;">Changing the battery, reinitialisation</td> <td>19</td> </tr> <tr> <td style="padding-right: 20px;">Key</td> <td>18</td> </tr> <tr> <td style="padding-right: 20px;">Starting</td> <td>55</td> </tr> <tr> <td style="padding-right: 20px;">Hill start assist</td> <td>56</td> </tr> <tr> <td style="padding-right: 20px;">Central locking / unlocking</td> <td>18, 27</td> </tr> </table>	Remote control	18-19	Changing the battery, reinitialisation	19	Key	18	Starting	55	Hill start assist	56	Central locking / unlocking	18, 27																				
Accessories	152																																				
Remote control	18-19																																				
Changing the battery, reinitialisation	19																																				
Key	18																																				
Starting	55																																				
Hill start assist	56																																				
Central locking / unlocking	18, 27																																				
<table border="0"> <tr> <td style="padding-right: 20px;">Zenith roof</td> <td>97-98, 101</td> </tr> <tr> <td style="padding-right: 20px;">Roof bars</td> <td>102</td> </tr> <tr> <td style="padding-right: 20px;">Rear lamps, direction indicators</td> <td>58-59</td> </tr> <tr> <td style="padding-right: 20px;">3rd brake lamp</td> <td>186</td> </tr> <tr> <td style="padding-right: 20px;">Changing rear bulbs</td> <td>181-182, 185-186</td> </tr> <tr> <td style="padding-right: 20px;">Doors, tailgate</td> <td>23-25</td> </tr> </table>	Zenith roof	97-98, 101	Roof bars	102	Rear lamps, direction indicators	58-59	3rd brake lamp	186	Changing rear bulbs	181-182, 185-186	Doors, tailgate	23-25			<table border="0"> <tr> <td style="padding-right: 20px;">Wiper blades</td> <td>191</td> </tr> <tr> <td style="padding-right: 20px;">Door mirrors</td> <td>110</td> </tr> <tr> <td style="padding-right: 20px;">Side repeaters</td> <td>184</td> </tr> <tr> <td style="padding-right: 20px;">Active City Brake</td> <td>122-125</td> </tr> </table>	Wiper blades	191	Door mirrors	110	Side repeaters	184	Active City Brake	122-125														
Zenith roof	97-98, 101																																				
Roof bars	102																																				
Rear lamps, direction indicators	58-59																																				
3rd brake lamp	186																																				
Changing rear bulbs	181-182, 185-186																																				
Doors, tailgate	23-25																																				
Wiper blades	191																																				
Door mirrors	110																																				
Side repeaters	184																																				
Active City Brake	122-125																																				
<table border="0"> <tr> <td style="padding-right: 20px;">Rear roof flap</td> <td>26</td> </tr> <tr> <td style="padding-right: 20px;">Emergency control</td> <td>23</td> </tr> </table>	Rear roof flap	26	Emergency control	23			<table border="0"> <tr> <td style="padding-right: 20px;">Front lamps, foglamps, direction indicators</td> <td>58-60, 181-184</td> </tr> <tr> <td style="padding-right: 20px;">Headlamp beam height adjustment</td> <td>60</td> </tr> <tr> <td style="padding-right: 20px;">Changing front bulbs</td> <td>181-184</td> </tr> <tr> <td style="padding-right: 20px;">Snow cover</td> <td>179</td> </tr> </table>	Front lamps, foglamps, direction indicators	58-60, 181-184	Headlamp beam height adjustment	60	Changing front bulbs	181-184	Snow cover	179																						
Rear roof flap	26																																				
Emergency control	23																																				
Front lamps, foglamps, direction indicators	58-60, 181-184																																				
Headlamp beam height adjustment	60																																				
Changing front bulbs	181-184																																				
Snow cover	179																																				
<table border="0"> <tr> <td style="padding-right: 20px;">Number plate lamps</td> <td>186</td> </tr> </table>	Number plate lamps	186			<table border="0"> <tr> <td style="padding-right: 20px;">Front doors</td> <td>21</td> </tr> <tr> <td style="padding-right: 20px;">Sliding side doors</td> <td>22-23</td> </tr> <tr> <td style="padding-right: 20px;">Key</td> <td>18</td> </tr> <tr> <td style="padding-right: 20px;">Opening the bonnet</td> <td>154</td> </tr> <tr> <td style="padding-right: 20px;">Child lock</td> <td>147</td> </tr> </table>	Front doors	21	Sliding side doors	22-23	Key	18	Opening the bonnet	154	Child lock	147																						
Number plate lamps	186																																				
Front doors	21																																				
Sliding side doors	22-23																																				
Key	18																																				
Opening the bonnet	154																																				
Child lock	147																																				
<table border="0"> <tr> <td style="padding-right: 20px;">Spare wheel, jack, changing a wheel, tools</td> <td>173-178</td> </tr> <tr> <td style="padding-right: 20px;">Temporary puncture repair kit</td> <td>172</td> </tr> <tr> <td style="padding-right: 20px;">Inflation, pressures</td> <td>201</td> </tr> </table>	Spare wheel, jack, changing a wheel, tools	173-178	Temporary puncture repair kit	172	Inflation, pressures	201		<table border="0"> <tr> <td style="padding-right: 20px;">Brakes, pads</td> <td>114, 157, 159</td> </tr> <tr> <td style="padding-right: 20px;">Emergency braking</td> <td>118</td> </tr> <tr> <td style="padding-right: 20px;">ABS, EBFd</td> <td>118</td> </tr> <tr> <td style="padding-right: 20px;">ASR, DSC</td> <td>119</td> </tr> <tr> <td style="padding-right: 20px;">Grip control</td> <td>120-121</td> </tr> <tr> <td style="padding-right: 20px;">Active City Brake</td> <td>122-125</td> </tr> <tr> <td style="padding-right: 20px;">Tyres, pressures</td> <td>201</td> </tr> <tr> <td style="padding-right: 20px;">Snow chains</td> <td>180</td> </tr> <tr> <td style="padding-right: 20px;">Tyre under-inflation detection</td> <td>41-42</td> </tr> <tr> <td style="padding-right: 20px;">Tyre under-inflation detection with reinitialisation</td> <td>43-46</td> </tr> </table>	Brakes, pads	114, 157, 159	Emergency braking	118	ABS, EBFd	118	ASR, DSC	119	Grip control	120-121	Active City Brake	122-125	Tyres, pressures	201	Snow chains	180	Tyre under-inflation detection	41-42	Tyre under-inflation detection with reinitialisation	43-46		<table border="0"> <tr> <td style="padding-right: 20px;">Filler cap, fuel tank</td> <td>161-162</td> </tr> <tr> <td style="padding-right: 20px;">Fuel cut-off, Diesel priming</td> <td>163</td> </tr> <tr> <td style="padding-right: 20px;">AdBlue®, topping up</td> <td>38-39, 164-169</td> </tr> </table>	Filler cap, fuel tank	161-162	Fuel cut-off, Diesel priming	163	AdBlue®, topping up	38-39, 164-169	
Spare wheel, jack, changing a wheel, tools	173-178																																				
Temporary puncture repair kit	172																																				
Inflation, pressures	201																																				
Brakes, pads	114, 157, 159																																				
Emergency braking	118																																				
ABS, EBFd	118																																				
ASR, DSC	119																																				
Grip control	120-121																																				
Active City Brake	122-125																																				
Tyres, pressures	201																																				
Snow chains	180																																				
Tyre under-inflation detection	41-42																																				
Tyre under-inflation detection with reinitialisation	43-46																																				
Filler cap, fuel tank	161-162																																				
Fuel cut-off, Diesel priming	163																																				
AdBlue®, topping up	38-39, 164-169																																				
<table border="0"> <tr> <td style="padding-right: 20px;">Towing, lifting</td> <td>192</td> </tr> <tr> <td style="padding-right: 20px;">Towbar, swan neck towball</td> <td>148-151</td> </tr> <tr> <td style="padding-right: 20px;">Parking sensors</td> <td>115-116</td> </tr> <tr> <td style="padding-right: 20px;">Reversing camera</td> <td>117</td> </tr> </table>	Towing, lifting	192	Towbar, swan neck towball	148-151	Parking sensors	115-116	Reversing camera	117																													
Towing, lifting	192																																				
Towbar, swan neck towball	148-151																																				
Parking sensors	115-116																																				
Reversing camera	117																																				

Location

INTERIOR

6

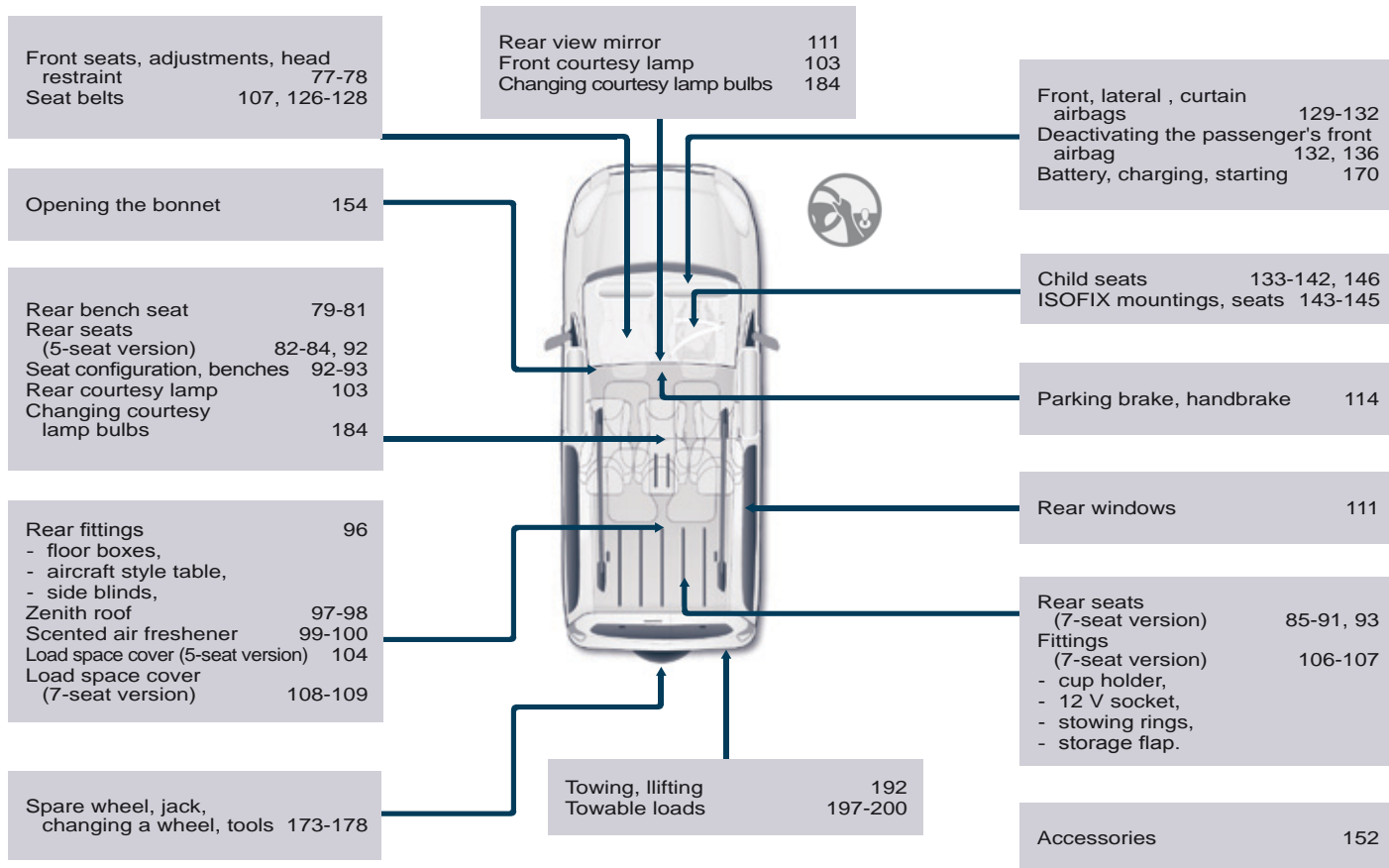

INTERIOR

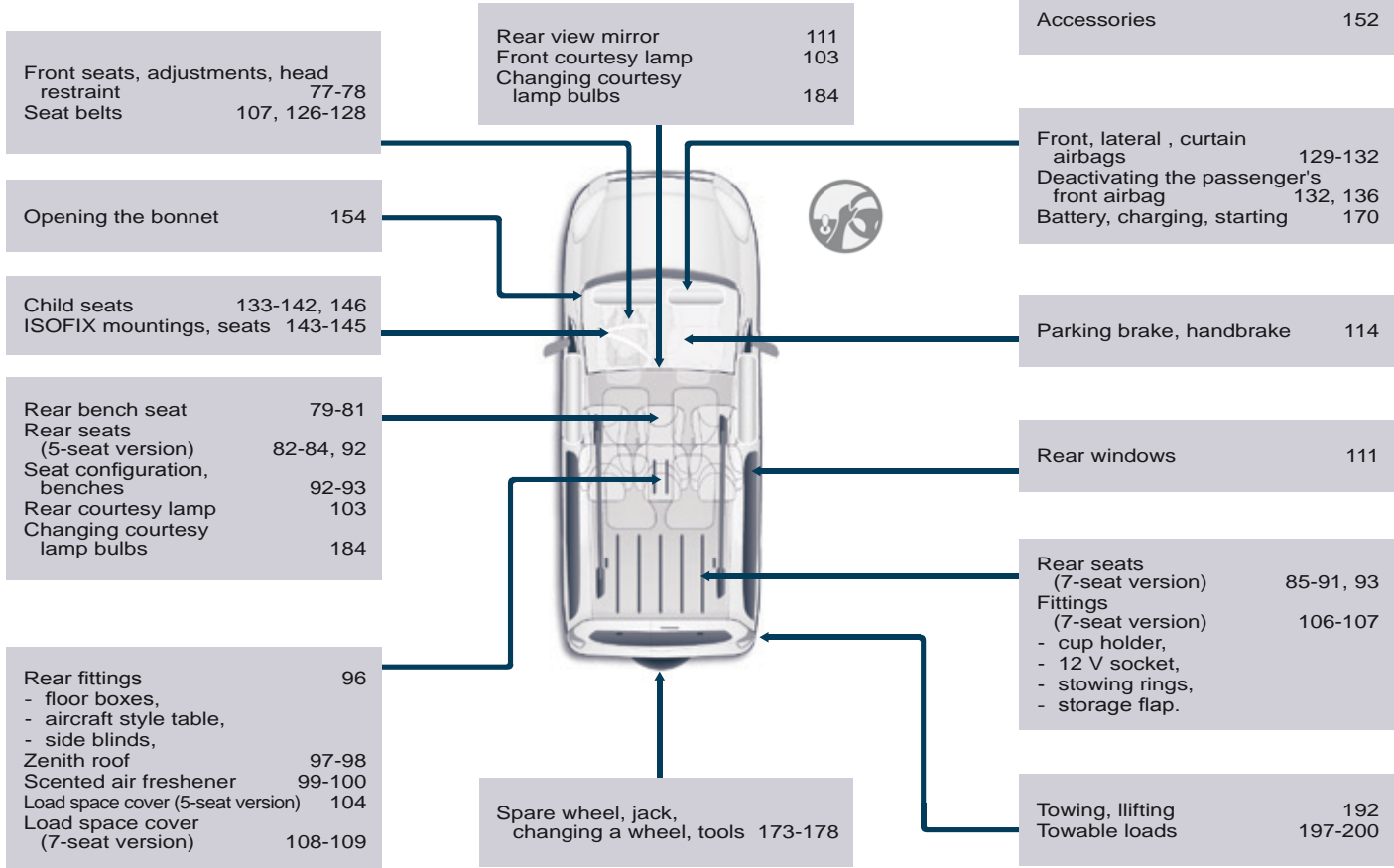

INSTRUMENTS AND CONTROLS

∞



Instrument panels, screens, dials	28-29
Setting the time in the instrument panel	29
Warning lamps, indicator lamps	32-39
Indicators, fuel gauge	40, 47-48
Lighting dimmer	48
Gear shift indicator	50

Wipers	61-62
Automatic rain sensitive wipers	61
Screen wash	62, 158
Trip computer	63

Lighting	58-60
Foglamps	59
LED daytime running lamps	59
Automatic illumination of headlamps	59-60

Cruise control	64-66
Speed limiter	67-69

ASR-ESC	119
Parking sensors	115-116
Electric mirrors	110
Headlamp beam height adjustment	60
Stop & Start	53-55

Dashboard, passenger compartment fuses	187-189
Opening the bonnet	154



Parking brake	114
---------------	-----



6-speed electronic gearbox	51-52
----------------------------	-------

Ignition switch	55
-----------------	----

Steering mounted controls:	
- Touch screen	206
- PEUGEOT Connect Sound (RD5)	267

Steering wheel adjustment	49
Horn	114

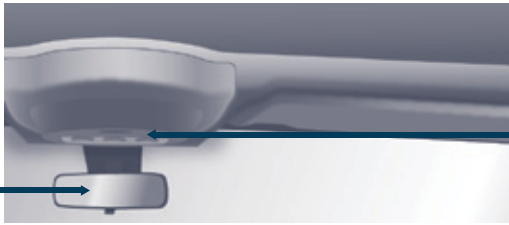

Rear view mirror 111
Child surveillance mirror 111

Courtesy lamps 103, 184

Touch screen 203-263
PEUGEOT Connect Sound (RD5) 265-282
Reversing camera 117



Screens, menus 28, 207, 268
Setting the time in the screen 30-31

Deactivating the passenger's front airbag 132, 136

Heating, ventilation
- heating 70-71, 74
- air conditioning A/C 70-71, 74
Digital air conditioning 72-73, 74
Demisting/defrosting 75-76

"Grip control" 120-121

Controls
- central locking 27
- electric child lock 147
- electric windows 112
- hazard warning lamps 114

Manual gearbox 49

Front fittings 94-95
- storage compartment.
- glove box,
- bottle holder,
- bag holder,
- centre console,
- overhead storage,
- sun visor,
- storage under seats.

INSTRUMENTS AND CONTROLS

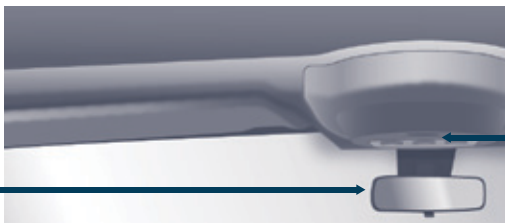

Rear view mirror 111
Child surveillance mirror 111

Courtesy lamps 103, 184

Screens, menus 28, 207, 268
Setting the time in the screen 30-31

Touch screen 203-263
PEUGEOT Connect Sound (RD5) 265-282
Reversing camera 117



Front fittings 94-95
- storage compartment.
- glove box,
- bottle holder,
- bag holder,
- centre console,
- overhead storage,
- sun visor,
- storage under seats.

"Grip control" 120-121

Heating, ventilation
- heating 70-71, 74
- air conditioning A/C 70-71, 74
Digital air conditioning 72-73, 74
Demisting/defrosting 75-76

Dashboard, passenger compartment fuses 187-189
Opening the bonnet 154



Controls
- central locking 27
- electric child lock 147
- electric windows 112
- hazard warning lamps 114

Manual gearbox 49



Lighting 58-60
 Foglamps 59
 LED daytime running lamps 59
 Automatic illumination of headlamps 59-60

6-speed electronic gearbox 51-52

Cruise control 64-66
 Speed limiter 67-69

Steering wheel adjustment 49
 Horn 114

Parking brake 114

Instrument panels, screens, dials 28-29
 Setting the time in the instrument panel 29
 Warning lamps, indicator lamps 32-39
 Indicators, fuel gauge 40, 47-48
 Lighting dimmer 48
 Gear shift indicator 50



Wipers 61-62
 Automatic rain sensitive wipers 61
 Screen wash 62, 158
 Trip computer 63

Deactivating the passenger's front airbag 132, 136

Ignition switch 55

ASR-ESC 119
 Parking sensors 115-116
 Electric mirrors 110
 Headlamp beam height adjustment 60
 Stop & Start 53-55

Steering mounted controls:
 - Touch screen 206
 - PEUGEOT Connect Sound (RD5) 267

TECHNICAL DATA - MAINTENANCE

12

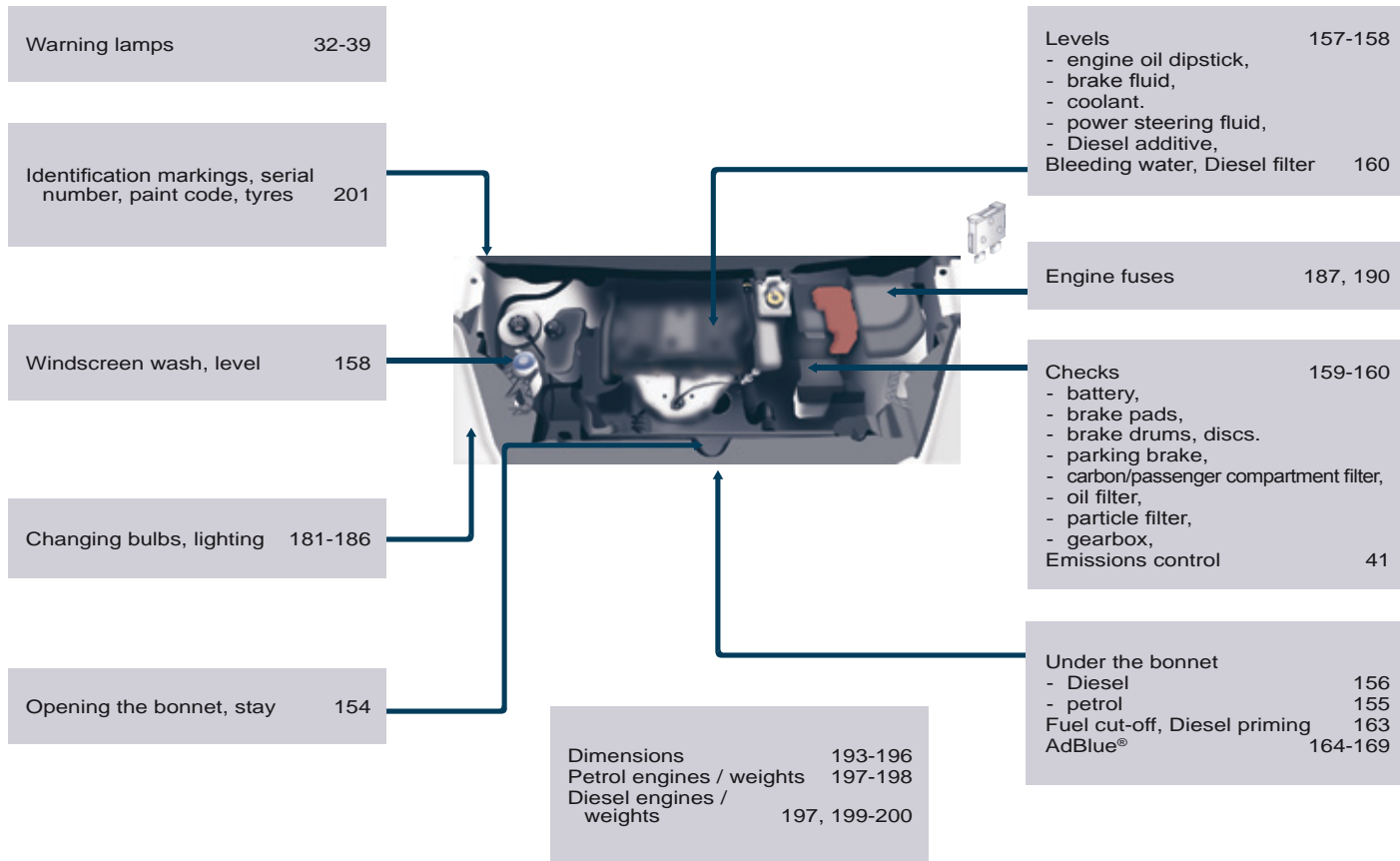

INSTRUMENTS AND CONTROLS

1. Lighting and direction indicator stalk.
2. Instrument panel with screen.
3. Wipers, screenwash, trip computer control stalk.
4. Ignition.
5. Audio system controls.
6. Driver's front airbag, horn.
7. Steering wheel height and reach adjustment.
8. Cruise control, speed limiter controls.
9. Switch panel, parking sensors, headlamp beam adjustment, ESC, Stop & Start.
10. Bonnet release.
11. Electric door mirror adjustment.
12. Electric window switches.
13. Switch panel: hazard warning lamps, central locking, child lock.
14. Cigarette lighter.
15. Heating-ventilation controls.
16. Electronic gearbox controls or Grip control button.
17. Touch screen.
18. USB port (with electronic gearbox)
19. USB port (with manual gearbox).





INSTRUMENTS AND CONTROLS

1. Lighting and direction indicator control stalk.
2. Instrument panel with screen.
3. Wiper, screenwash, trip computer control stalk.
4. Ignition switch.
5. Audio system controls.
6. Driver's front airbag, horn.
7. Steering wheel height and reach adjustment.
8. Cruise control, speed limiter controls.
9. Switch panel, parking sensors, headlamp beam adjustment, ESC, Stop & Start, alarm.
10. Bonnet release lever.
11. Electric door mirror controls.
12. Electric window switches.
13. Switch panel: hazard warning, central locking, child lock.
14. Cigarette lighter.
15. Heating-ventilation controls.
16. Electronic gearbox controls or Grip control button.
17. Touch screen.
18. USB port (with electronic gearbox).
19. USB port (with manual gearbox).



Environment

With you, PEUGEOT acts to protect the environment.

We invite you to visit the www.peugeot.co.uk website.

As the driver, you also can contribute to protecting the environment in the following way:

- drive smoothly, without frequent and harsh acceleration,
- observe the service intervals; we recommend that services are carried out by a PEUGEOT dealer, authorised to collect used batteries and fluids,
- in order to preserve the reliability of the engine and emission control systems, do not use engine oil additives.

 Refer to information on eco-driving at the end of this section.

Eco-driving

Eco-driving is a range of everyday practices that allow the motorist to optimise their fuel consumption and CO₂ emissions.

Optimise the use of your gearbox

With a manual gearbox, move off gently and change up without waiting. During acceleration change up early.

With an automatic or electronic gearbox, give preference to automatic mode and avoid pressing the accelerator pedal heavily or suddenly.

The gear efficiency indicator invites you to engage the most suitable gear: as soon as the indication is displayed in the instrument panel, follow it straight away.

For vehicles fitted with an electronic or automatic gearbox, this indicator appears only in manual mode.

Drive smoothly

Maintain a safe distance between vehicles, use engine braking rather than the brake pedal, and press the accelerator progressively. These practices contribute towards a reduction in fuel consumption and CO₂ emissions and also help to reduce the background traffic noise.

If your vehicle has cruise control, make use of the system at speeds above 25 mph (40 km/h) when the traffic is flowing well.

Control the use of your electrical equipment

Before moving off, if the passenger compartment is too warm, ventilate it by opening the windows and air vents before using the air conditioning.

Above 30 mph (50 km/h), close the windows and leave the air vents open.

Remember to make use of equipment that can help keep the temperature in the passenger compartment down (sunroof and window blinds...).

Switch off the air conditioning, unless it has automatic regulation, as soon as the desired temperature is attained.

Switch off the demisting and defrosting controls, if not automatic. Switch off the heated seat as soon as possible.

Switch off the headlamps and front foglamps when the level of light does not require their use.

Avoid running the engine before moving off, particularly in winter; your vehicle will warm up much faster while driving.

As a passenger, if you avoid connecting your multimedia devices (film, music, video game...), you will contribute towards limiting the consumption of electrical energy, and so of fuel.

Disconnect your portable devices before leaving the vehicle.

Limit the causes of excess consumption

Spread loads throughout the vehicle; place the heaviest items in the bottom of the boot, as close as possible to the rear seats.

Limit the loads carried in the vehicle and reduce wind resistance (roof bars, roof rack, bicycle carrier, trailer...). Use a roof box in preference.

Remove roof bars and roof racks after use.

At the end of winter, remove snow tyres and refit your summer tyres.

Observe the recommendations on maintenance

Check the tyre pressures regularly, when cold, referring to the label in the door aperture, driver's side.

Carry out this check in particular:

- before a long journey,
- at each change of season,
- after a long period out of use.

Don't forget the spare wheel and the tyres on any trailer or caravan.

Have your vehicle serviced regularly (engine oil, oil filter, air filter, passenger compartment filter...) and observe the schedule of operations recommended in the manufacturer's service schedule.

With a BlueHDi Diesel engine, if the SCR system is faulty your vehicle becomes polluting; go to a PEUGEOT dealer or a qualified workshop without delay to have the emissions of nitrogen oxides brought back to the legal level.

When refuelling, do not continue after the third cut-off of the nozzle to avoid any overflow.

At the wheel of your new vehicle, it is only after the first 1 800 miles (3 000 kilometres) that you will see the fuel consumption settle down to a consistent average.



KEY

This locks and unlocks the vehicle's doors, opens and closes the fuel filler cap, as well as starting and stopping the engine.



REMOTE CONTROL

Unlocking



Press this button to unlock all of your vehicle's doors.

The direction indicators flash twice.

Locking



Press this button to lock all of your vehicle's doors.

The direction indicators flash once.

If one of the doors is open or is not closed correctly, the central locking will not work.

Deadlocking

A second press on the closed padlock on the remote control within five seconds after locking changes the locking to deadlocking.

This is confirmed by fixed lighting of the direction indicators for approximately two seconds.

Deadlocking renders the exterior and interior door opening handles inoperative: do not leave anyone inside the vehicle when it is deadlocked.

If deadlocking is activated from inside the vehicle using the remote control, it will change to normal locking when the vehicle is started.

Unfolding / folding



If you do not press the button, you may damage the key's folding mechanism.

Good practice

Take care not to allow the remote control to come into contact with grease, dust, rain or a damp environment.

A heavy object attached to the key (key ring, ...) weighing on the shaft of the key in the switch, may cause a malfunction.



REMOTE CONTROL

Changing the battery

Battery ref.: CR1620 / 3 volts.

The "battery flat" information is given by an audible signal, accompanied by a message in the screen.

To replace the battery, unclip the casing using a coin at the ring.

If the remote control does not work after the battery has been changed, reinitialise the remote control.

There is a risk of damage if the replacement battery is not the correct type.

i Use only identical batteries or batteries of an equivalent type to those recommended by PEUGEOT dealers.

Do not discard the remote control batteries, they contain metals which are harmful to the environment.

Deposit them at a PEUGEOT dealership, or at an authorised collection point.

Reinitialising the remote control

Following changing of the remote control battery or disconnection of the vehicle battery, the remote control may have to be reinitialised.

Wait at least one minute before using the remote control.

Insert the key in the ignition switch with the buttons (padlocks) of the remote control facing you.

Switch on the ignition.

Press the locking padlock for at least five seconds within the next ten seconds.

Switch off the ignition.

Wait at least one minute before using the remote control.

The remote control is now working again.

ELECTRONIC IMMOBILISER

All of the keys contain an electronic immobiliser device.

This device locks the engine supply system. It is activated automatically when the key is removed from the ignition.

After the ignition is switched on, a dialogue is established between the key and the electronic immobiliser system.

The metal part of the key must be unfolded correctly for correct dialogue to take place.

If you lose your keys

Visit a PEUGEOT dealer with the vehicle's V5 registration certificate and your identification document.

A PEUGEOT dealer will be able to retrieve the key code and the transponder code so that a replacement key can be ordered.

Good practice

Do not make any modifications to the electronic immobiliser system.

Operating the remote control, even when it is in your pocket, may result in involuntary unlocking of the doors.

The simultaneous use of other high frequency equipment (mobile telephones, domestic alarms...), may interfere with the operation of the remote control temporarily.

The remote control does not operate while the key is in the ignition, even if the ignition is off.

When purchasing a second-hand vehicle, have the keys memorised by a PEUGEOT dealer, so as to be sure that the keys in your possession are the only ones that can be used to start the vehicle.

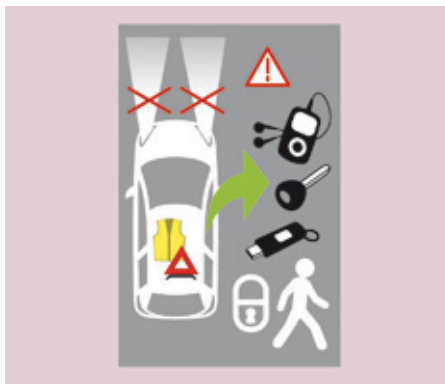

Don't forget

When leaving the vehicle, check that the lighting is off and nothing of value is visible.

As a safety precaution (with children on board), remove the key from the ignition when leaving the vehicle, even for a short time.



ALARM

If fitted on your vehicle, this provides two types of protection:

- exterior protection: it sounds if a front/rear door or the bonnet is opened.
- interior protection: it sounds if the volume inside the passenger compartment changes (breaking of a window or a movement inside the vehicle).

If your vehicle is fitted with a separation partition, the interior protection is not active in the load space.

Locking the vehicle with complete alarm

Setting the alarm

- Switch off the ignition and get out of the vehicle.
- Set the alarm within five minutes of getting out of the vehicle, by locking or deadlocking using the remote control. The red LED, located in the button, flashes once per second.

Disarming

- Unlock the vehicle with the remote control or switch on the ignition, the red LED goes off.

Locking the vehicle with exterior protection only

If, while you are away from the vehicle, you wish to leave a window partially open or a pet inside the vehicle, you should choose exterior protection only.

- Switch off the ignition.



- In the next ten seconds, press the button until the red LED is on continuously.

- Get out of the vehicle.
- Within the next five minutes, set the alarm by locking or deadlocking using the remote control (the red LED flashes once a second).

Triggering

The siren sounds, the direction indicators flash for approximately 30 seconds and the red LED flashes rapidly.

- To switch it off, insert the key and switch on the ignition.

When the alarm has been triggered ten times in succession (when triggered for the eleventh time) it is deactivated. Repeat the procedure for setting the alarm.

Locking the vehicle without alarm

- Insert the key in the lock on the driver's door and lock it.

Do not set the alarm when washing your vehicle.

Failure of the remote control

When the alarm is set but the remote control does not operate:

- Unlock the doors with the key and open the door. The alarm is triggered.
- Switch on the ignition in the next ten seconds. The alarm is disarmed.

Incorrect operation

When the ignition is switched on, if the red LED remains on for ten seconds, there is a fault in the siren connection.

Contact a PEUGEOT dealer to have the system checked.

Automatic setting of the alarm

Depending on the country in which the vehicle is sold, the alarm is set automatically approximately 2 minutes after the last door is closed.

To prevent triggering of the alarm when a door is opened, you have to press the remote control unlocking button again.

- ⓘ Do not make any modifications to the alarm system as this could cause faults.



FRONT DOORS

From the outside

Use the remote control to lock/unlock the vehicle.

Insert the metal part of the key in the lock on the driver's side if the remote control does not work.



From the inside

Use the door opening control to unlock and open the door concerned.

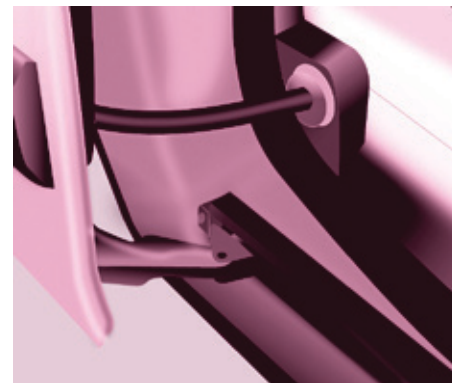

SLIDING SIDE DOORS

From the outside

Pull the handle towards you then towards the rear and open the side door guiding the rearward sliding to beyond the point of resistance to hold it open.

A mechanical system prevents opening of the left-hand side door when the fuel filler flap is open.

From the inside

Unlock the side door using this handle and open it, guiding the rearward sliding to the point of resistance. Pass this point to hold the door open.

Close the side door using the handle to start the sliding and pass the point of resistance. Then, use the shaped recess at the top of the door pillar to guide the door until it locks.

Do not use the grab handle to slide the door.

Good practice

Take care not to block the guide space on the floor to allow the door to slide correctly.

If your vehicle is parked on a slope, guide the sliding of the side door. In fact, the door could open or close more rapidly due to the slope of the ground and could cause injury.

For safety and operation reasons, do not drive with the sliding side doors open.



Operation in the event of a battery failure

Front and side passenger doors

In the event of a battery or of the central locking fault, use the lock to lock the doors mechanically.

- To open the door and get out of the vehicle, pull the interior control.
- To lock the door, insert the key in the lock, located on the edge of the door, then turn it **one eighth of a turn**.

Driver's door

- Insert the key in the lock, then turn it to the right to lock or to the left to unlock.



TAILGATE

Opening

From outside

Locking/unlocking is by means of the remote control.

To open, press the control below the trim then raise the tailgate.

A pull strap is available to close the tailgate from the high position.

Guide the closing of the tailgate to the balance point of its travel then push on the tailgate to close it fully.



From inside

(emergency control)

In the event of a central unlocking operating fault, this permits unlocking of the tailgate from the inside.

Insert a small screwdriver in the opening, between the tailgate and the floor. To unlock the lock, move the catch to the left then push the tailgate.



Tailgate screen

The opening rear screen allows you to access the rear of the vehicle directly, without having to open the tailgate.

Opening

After unlocking the vehicle using the remote control or the key, press the control and raise the rear screen to open it.

Closing

Close the rear screen by pressing the centre of the glass until it is fully closed.

i The tailgate and tailgate screen cannot both be open at the same time, to prevent damage to the screen.



HINGED REAR DOORS

The hinged rear doors are asymmetrical (2/3 - 1/3), with the smaller door on the right. They are fitted with a central lock.

From outside

To open, pull the handle towards you.



Pull the lever to open the right-hand door.

To close, start with the right-hand door then close the left-hand door.

With the roof rear flap, the rear bumper has been reinforced to serve as a footrest when entering the vehicle.



In practice

It is possible to drive with the right-hand door open to make it easier to carry long loads. The left-hand door is kept closed by the distinctive "yellow" lock, positioned at the base of the door. This closed door must not be used as a load retainer.

Driving with the right-hand door open is a special dispensation. Comply with the usual safety indications to warn other drivers.



Opening to approximately 180°

A check strap system permits extension of the opening from approximately 90° to approximately 180°.

Pull the yellow control when the door is open.

The check strap will engage again automatically on closing.

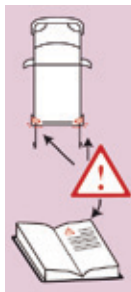

When parked with the rear doors open to 90°, the doors mask the rear lamps. To signal your position to other road users driving in the same direction who may not have seen your vehicle, use a warning triangle or other device required by the legislation in your country.

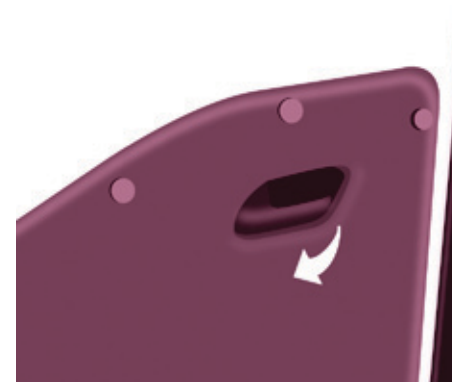

From inside

When present on the vehicle, pulling this handle towards you opens the left-hand door.

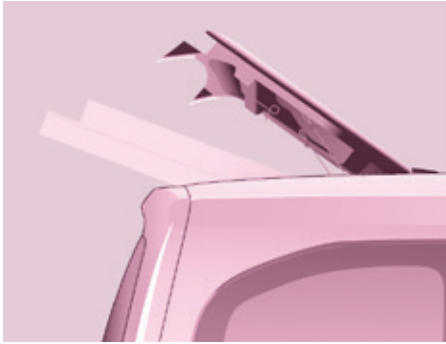

REAR ROOF FLAP

This rear roof flap is only compatible with side-hinged rear doors.

To open the rear roof flap:

- raise the black paddle of the toggle,
- relieve the toggle by pressing the rear roof flap (downwards) then release the hook,
- lift the rear roof flap,
- pass the point of resistance to secure the rear roof flap using the support stays.

Never drive without the stays in place.

To close the rear roof flap:

- check that the support bar is secured correctly,
- lower the rear roof flap,
- while pressing the rear roof flap (downwards), take hold of the two loops of the spring then place the hook in its housing,

- lower the black paddle to secure the rear roof flap.

Securing the rear roof flap places it on the seal correctly and ensures sealing without noise.

Support bar

A support bar is provided for transporting long loads, after opening the rear roof flap.

Fold back the support bar by lifting the lever.

Guide it to the door pillar.

Support the long loads to be transported, lift them and reposition the support bar with one hand.

Ensure that it is secured correctly by pressing the handle downwards past the point of resistance and secure the loads firmly.

The side supports can be used as hooking points.

Never attach any load to the rear roof flap.

i The rear bumper has been reinforced to serve as a footrest when entering the vehicle.

Never drive without the support bar in place.

! The rear doors only lock when the support bar is installed.

When the rear roof flap is open, take care when driving where height is restricted.

Never rest loads directly on the rear doors.

Comply with the usual indications, to warn other drivers.

Reserve the use of the rear roof flap for short journeys.

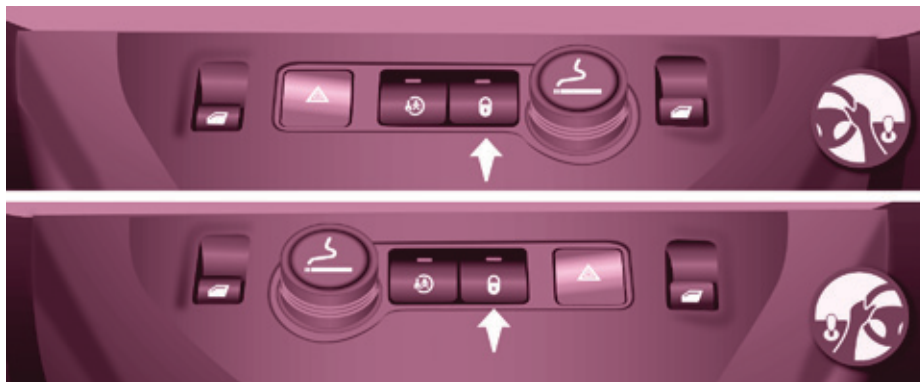

CENTRAL LOCKING



An initial press permits central locking of the vehicle, when all of the doors are closed.

A second press permits central unlocking of the vehicle.

The control is inactive when the vehicle has been locked using the remote control or the key from the outside.

The doors can still be opened from the inside.

The control switch LED:

- flashes when the doors are locked with the vehicle stationary and the engine off,
- comes on when the doors are locked and from the time the ignition is switched on.



Driving with the doors locked may make access to the interior more difficult in an emergency.

Anti-intrusion security

Locking while driving

When the vehicle moves off, as soon as you reach approximately 6 mph (10 km/h), the system locks the doors. The characteristic central locking noise is heard. The LED in the switch on the dashboard central switch panel comes on.

During the journey, opening a door results in complete unlocking of the vehicle.

Activating / deactivating the function



With the ignition on, press and hold this switch to activate or deactivate the function.

Door open warning lamp



If this warning lamp comes on, check that all of your vehicle's doors are closed correctly.

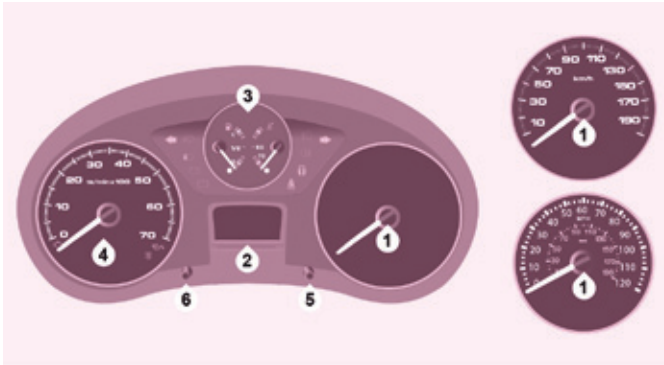

INSTRUMENT PANEL

Dials

1. Distance recorder in kilometres / miles.
2. Display screen.
3. Fuel gauge, coolant temperature gauge.
4. Rev counter.
5. Trip distance recorder / service indicator reset.
6. Instrument panel lighting dimmer.

Display screens

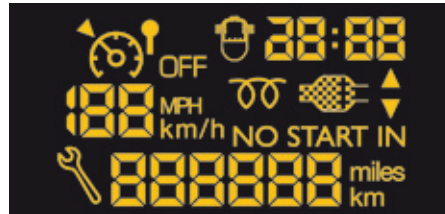

Level 1

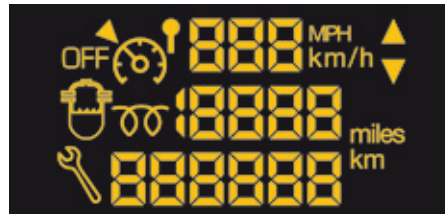

Level 2

with the touch screen



Screens

The format of the information presented in the screen depends on the vehicle's equipment level.



Instrument panel without screen

DATE AND TIME

Centre console without screen



To adjust the time, use the left-hand button on the instrument panel:

- Turn to the left: the minutes flash.
- Turn to the right to increase the minutes (hold the button to the right for rapid scrolling).
- Turn to the left: the hours flash.
- Turn to the right to increase the hours (hold the button to the right for rapid scrolling).

- Turn to the left: 24H or 12H is displayed.
- Turn to the right to select 24H or 12H.
- Turn to the left to complete the time adjustment.

After approximately 30 seconds without any action, the screen returns to the normal display.



Centre console with screen



The display - time sequence is linked according to model (version). The access to the "Date" adjustment is only active when the model version offers a date in words.

Instruments and controls



Screen C



Press the **MENU** button.



Using the arrows, select **PERSONALISATION CONFIGURATION**.



Press to confirm the selection.



Using the arrows, select **DISPLAY CONFIGURATION**.



Press to confirm the selection.



Using the arrows, select **ADJUST DATE AND TIME**.



Press to confirm the selection.



Adjust the settings one by one confirming by pressing the **OK** button.



Then select the OK tab in the screen and confirm.



Touch screen



☞ Select the "**Configuration**" menu.



☞ In the secondary page, press on "**Time/Date**".

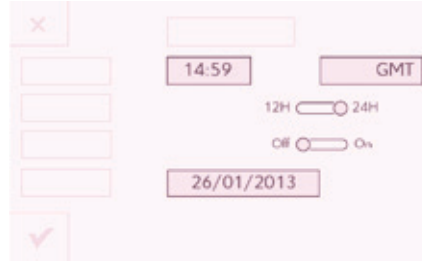

☞ Select "**Adjust time**" or "**Adjust date**" and modify the settings using the number keypad, then confirm.









☞ Press "**Confirm**" to quit.

WARNING LAMPS





32







Each time the vehicle is started: a series of warning lamps comes on applying a self-test check. They go off almost immediately. Engine running: the lamp becomes a warning if it remains on continuously or flashes. This initial warning may be accompanied by an audible signal and a message in the screen. Do not ignore these warnings.

Warning lamp		is	indicates	Solution - action
	STOP	on, associated with another warning lamp and accompanied by a message in the screen.	major faults linked with the "Brake fluid level", "Engine oil pressure and temperature", "Coolant temperature", "Electronic brake force distribution" and "Power steering" warning lamps.	You must stop as soon as it is safe to do so. Park and switch off the ignition. Have it checked by a PEUGEOT dealer or a qualified workshop.
	Parking brake / Brake fluid level / EBFD	on.	that the parking brake is applied or has not been released fully.	Releasing the parking brake switches off the warning lamp.
		on.	low brake fluid level.	Top up using a fluid recommended by PEUGEOT.
		remaining on even though the level is correct and associated with the ABS warning lamp.	a fault with the electronic brake force distribution.	You must stop as soon as it is safe to do so. Park and switch off the ignition. Have it checked by a PEUGEOT dealer or a qualified workshop.
	Engine oil pressure and temperature	on while driving.	low pressure or a high temperature.	Park and switch off the ignition then allow to cool. Visually check the level. Chapter 7, "Levels" section.
		remaining on, even though the level is correct.	a major fault.	Have it checked by a PEUGEOT dealer or a qualified workshop.





Warning lamp		is	indicates	Solution - action
	Coolant temperature and level	on with needle in the red zone.	an abnormal increase in temperature.	Park and switch off the ignition then allow to cool. Visually check the level.
		flashing.	a drop in the coolant level.	Chapter 7, "Levels" section. Contact a PEUGEOT dealer or a qualified workshop.
	Service	on temporarily.	minor faults or warnings.	Consult the alert log in the display or screen. If your vehicle is equipped with a trip computer or a screen: refer to the "Steering mounted controls" section in Chapter 4. Contact a PEUGEOT dealer or a qualified workshop.
		remaining on.	major faults.	
	Seat belt not fastened	on then flashing.	the driver and/or front passenger has not fastened their seat belt.	Pull the strap then insert the tongue in the buckle.
		accompanied by an audible signal then remains on.	the vehicle is moving with the driver's and/or front passenger's seat belt not fastened.	Check that the seat belt is fastened by pulling the strap. Chapter 5, "Seat belts" section.
	ECO	on.	The Stop & Start system has put the engine in STOP mode following a vehicle stop (red light, traffic jam, etc...).	As soon as you want to move off, the warning lamp goes off and the engine restarts automatically in START mode.
		flashes for a few seconds, then goes off.	STOP mode is temporarily unavailable. or START mode has been invoked automatically.	Chapter 3, "Stop & Start" section.







Instruments and controls

Warning lamp		is	indicates	Solution - action
	Front / lateral airbag	flashing or remaining on.	a failure of an airbag.	Have the system checked by a PEUGEOT dealer or a qualified workshop without delay. Chapter 5, "Airbags" section.
	Front passenger's airbag deactivated	on.	the intentional deactivation of this airbag in the presence of a rearward facing child seat.	Chapter 5, "Airbags" or "child safety" section.
	Low fuel level	on with gauge needle in the red zone.	When it first comes on, there remains around 8 litres of fuel in the tank. The distance you can drive on this fuel depends on your style of driving and the engine type.	You must fill up with fuel to avoid running out. This warning lamp comes on each time you switch on the ignition until you have filled up. Capacity of the tank: approximately 60 litres (or 55 litres according to version). Never risk driving until the tank is empty, this could damage the emissions and injection systems.
		flashing.	cutting off of the fuel supply following a serious impact.	Restore the supply. Chapter 7, "Fuel" section.
	EOBD emission control system	flashing or remaining on.	a failure of the system.	There is a risk of damage to the catalytic converter. Have it checked by a PEUGEOT dealer or a qualified workshop.
	Battery charge	on.	a fault in the charging circuit.	Check the battery terminals, ... Chapter 8, "Battery" section.
		flashing.	placing of the active functions on standby (economy mode).	Chapter 8, "Battery" section.
		remaining on, in spite of the checks.	an ignition or injection malfunction.	Have it checked by a PEUGEOT dealer or a qualified workshop.





Warning lamp		is	indicates	Solution - action
	Power steering	on.	a fault with the system.	The vehicle retains conventional steering without assistance. Have it checked by a PEUGEOT dealer or a qualified workshop.
	Door open detection	on and accompanied by a message in the screen.	that a door is not closed correctly.	Check that all of the doors are closed.
	ABS	remaining on.	a fault with the anti-lock braking system.	The vehicle retains conventional braking. Have it checked by a PEUGEOT dealer or a qualified workshop.
	ESC	flashing.	triggering of the ASR or DSC regulation.	The system optimises traction and improves the directional stability of the vehicle. Chapter 5, "Driving safety" section.
		remaining on.	a fault with the system. E.g.: under-inflation of the tyres.	E.g.: check the pressure of the tyres. Have it checked by a PEUGEOT dealer or a qualified workshop. (Wheel speed sensor, hydraulic valve block, ...).
	Under-inflation	on.	The tyre pressure is too low in or more wheels.	Check the tyre pressure as soon as possible. This check must be done with the tyres cold.
		flashing then remaining on, accompanied by the Service warning lamp, and depending on equipment, the display of a message.	The tyre pressure monitoring system has a fault or one of the wheels does not have a sensor.	Detection of under-inflation is no longer assured. Have it checked by a PEUGEOT dealer or a qualified workshop.
	Particle filter	on.	a problem with the particle filter (fuel additive level, risk of blockage, ...).	Have the filter checked by a PEUGEOT dealer or a qualified workshop. Chapter 7, "Levels" section.

Instruments and controls

Warning lamp		is	indicates	Solution - action
	Dipped beam headlamps / Daytime running lamps	on.	a manual selection or automatic illumination of headlamps.	Turn the ring on the lighting control stalk to the second position.
			illumination of the dipped beam headlamps from the time the ignition is switched on: daytime running lamps (depending on the country in which the vehicle is sold).	Chapter 4, "Steering mounted controls" section.
	Main beam headlamps		pulling of the stalk towards you.	Pull the stalk to return to dipped beam headlamps.
	Direction indicators	flashing with audible signal.	a change of direction via the lighting stalk.	Flashing right: push stalk downwards. Flashing left: push stalk upwards.
	Front foglamps	on.	a manual selection.	The foglamps only operate if the sidelamps or dipped beam headlamps are on.
	Rear foglamps	on.	a manual selection.	The foglamps only operate if the sidelamps or dipped beam headlamps are on. In conditions of normal visibility, switch them off to avoid breaking the law. "This lamp is a dazzling red".



Warning lamp in the screen	is	indicates	Solution - action
 Cruise control	on.	cruise control selected.	Manual selection. Chapter 4, "Steering mounted controls" section.
 Speed limiter	on.	speed limiter selected.	Manual selection. Chapter 4, "Steering mounted controls" section.
 Gear shift indicator	on.	a recommendation independent of the type and density of traffic.	To reduce fuel consumption, change to an appropriate gear with a manual gearbox. The driver retains responsibility to follow this indication or not.
 Diesel pre-heating	on.	climatic conditions requiring pre-heating.	Wait until the warning lamp goes off before operating the starter.
 Presence of water in the Diesel filter	on and accompanied by a message in the screen.	water in the Diesel filter.	Have the filter bled by a PEUGEOT dealer or a qualified workshop without delay. Chapter 7, "Checks" section. According to country.
 Service spanner	on.	that a service will be due shortly.	Refer to the list of checks in the warranty and maintenance record. Have the service carried out by a PEUGEOT dealer or a qualified workshop.
 Time	flashing.	adjustment of the time.	Use the left-hand button on the instrument panel. Chapter 3, "Instruments and controls" section.

AdBlue®

Alert	Information	Solution - action
	<p>1st level of alert</p> <p>There is an audible signal when the ignition is switched on. The warnings are intermittent and then become permanent when switching on the ignition or when driving.</p> <p>The remaining driving range is counted down from 1 500 miles (2 400 km) to 375 miles (600 km). The range figure reduces in steps of 200 miles (300 km).</p>	<p>The contents of the AdBlue® tank has dropped to a level sufficient for a range of less than 1 500 miles (2 400 km).</p> <p>Have the fluid topped-up using an AdBlue® container or bottles.</p>
 	<p>2nd level of alert</p> <p>There is an audible signal when the ignition is switched on.</p> <p>The warnings are intermittent (every 30 seconds) and then become permanent every time the ignition is switched on or when driving.</p> <p>The remaining driving range is counted down from 350 miles (600 km) to zero, reducing in steps of 30 miles (50 km).</p>	<p>You must have the AdBlue® topped-up and not wait for a breakdown.</p>
<p>In the display screen.</p>	<p>Temporary display: "NO START IN".</p>	
<p>In the touch screen.</p>	<p>Select:</p> <ul style="list-style-type: none">  - "Driving assistance".  - "Diagnostic". <p>CHECK</p>	<p>The driving range is displayed.</p>
	<p>3rd level of alert</p> <p>The AdBlue® tank is empty.</p>	<p>Starting is impossible.</p> <p>It is essential to add at least 3.8 litres of AdBlue® additive to the additive tank.</p>

 For more information on filling, refer to the chapter 7, AdBlue® section.

SCR emissions control system - BlueHDi Diesel

Alerts	Information	Solution - action
 +  + 	<p>The UREA, Service and diagnostic warning lamps come on, an SCR emissions control system fault has been detected.</p> <p>After 30 miles (50 km) without AdBlue® Confirmation of the fault which is not related to a lack of fluid.</p>	<p>This is a temporary fault, the alert disappears as soon as the exhaust emissions return to normal levels.</p> <p>The remaining driving range 700 miles (1 100 km). Go to a PEUGEOT dealer or a qualified workshop as soon as possible to avoid a breakdown.</p>
	<p>The fault is confirmed. The next time the ignition is switched on, the authorised driving range will be displayed in miles (kilometres) and the alert will be repeated every 30 seconds. The limit of the driving range has been reached, exhaust emissions levels are above the limits. Starting is impossible.</p>	<p>To restart the engine, you must contact a PEUGEOT dealer or a qualified workshop.</p>



FUEL GAUGE

The fuel level is tested each time the key is turned to the "running" position.

The gauge is positioned on:

- **1**: the fuel tank is full, approximately 60 litres.
- **0**: the reserve is now being used, the warning lamp comes on continuously. The reserve when the warning first comes on is approximately 8 litres.



Refer to chapter 7, "Fuel" section.



COOLANT TEMPERATURE

The needle is positioned before the red zone: normal operation.

In arduous conditions of use or hot climatic conditions, the needle may move close to the red graduations.

What you should do if the needle enters the red zone:

Reduce your speed or let the engine run at idle.

What you should do if the warning lamp comes on:

- stop immediately, switch off the ignition. The fan may continue to operate for a certain time, up to approximately 10 minutes,
- wait for the engine to cool down in order to check the coolant level and top it up if necessary.

As the cooling system is pressurised, follow the procedure below to avoid the risk of scalding:

- wait at least one hour after switching off the engine before carrying out any work,
- unscrew the cap by 1/4 turn to allow the pressure to drop,
- when the pressure has dropped, check the level in the header tank,
- if necessary, remove the cap to top up.

If the needle remains in the red zone, have the system checked by a PEUGEOT dealer or a qualified workshop.



Refer to chapter 7, "Levels" section.

EMISSIONS CONTROLS



EOBD (European On Board Diagnosis) is a diagnostics system which complies with, among others, the standards on emissions limits of:

- CO (carbon monoxide),
- HC (unburnt hydrocarbons),
- NOx (nitrogen oxides), detected by oxygen sensors placed downstream of the catalytic converters,
- particles.

i The driver is warned of any malfunction of this emissions control system by the illumination of this warning lamp in the instrument panel.

If this warning lamp comes on, have it checked by a PEUGEOT dealer or a qualified workshop.

UNDER-INFLATION DETECTION



This system continuously monitors the pressures of the four tyres, as soon as the vehicle is moving.

A pressure sensor is located in the valve of each tyre (except the spare wheel).

The system triggers an alert if a drop in pressure is detected in one or more tyres.

i The tyre under-inflation detection system is an aid to driving which does not replace the need for vigilance on the part of the driver.

i This system does not avoid the need to check the tyre pressures regularly (including the spare wheel) and before a long journey.

Driving with under-inflated tyres adversely affects road holding, extends braking distances and causes premature tyre wear, particularly under arduous conditions (vehicle loaded, high speed, long journey).

i Driving with under-inflated tyres increases fuel consumption.

i The tyre pressures for your vehicle can be found on the tyre pressure label.

+ Refer to chapter 9, "Identification markings" section.

The tyre pressures must be checked when the tyres cold (vehicle stopped for 1 hour or after driving for less than 6 miles (10 km) at moderate speed). Otherwise, add 0.3 bar to the values indicated on the label.

Under-inflation alert



The alert is given by the fixed illumination of this warning lamp, accompanied by an audible signal, and depending on equipment, the display of a message.

In the event of a problem on one of the tyres, the symbol or the message appears, according to equipment, to identify it.

- Reduce speed, avoid sudden steering movements or harsh brake applications.
- Stop as soon as it is safe to do so.
- In the event of a puncture, use the temporary puncture repair kit or the spare wheel (according to equipment),
or
- if you have a compressor, the one in the temporary puncture repair kit for example, check the four tyre pressures when cold,
or
- if it is not possible to check the tyre pressures at the time, drive carefully at reduced speed.



The loss of pressure detected does not always lead to visible deformation of the tyre. Do not rely on just a visual check.



The alert is maintained until the tyre or tyres concerned is reinflated, repaired or replaced.

The spare wheel (space-saver type or a steel rim) does not have a sensor.

Operating fault



The flashing and then fixed illumination of the under-inflation warning lamp accompanied by the illumination of the "Service" warning lamp, and depending on equipment, the display of a message indicates a fault with the system.

In this case, monitoring of the tyre pressures is not assured.



This alert is also displayed when one or more wheels is not fitted with a sensor (for example, a space-saver or steel spare wheel).

Go to a PEUGEOT dealer or a qualified workshop to have the system checked or, following the repair of a puncture, to have the original wheel, equipped with a sensor, refitted.

UNDER-INFLATION DETECTION WITH REINITIALISATION

System which automatically checks the pressures of the tyres while driving.

The system monitors the pressures in the four tyres, once the vehicle is moving.

It compares the information given by the four wheel speed sensors with **reference values, which must be reinitialised every time the tyre pressures are adjusted or a wheel changed.**

The system triggers an alert as soon as it detects a drop in the inflation pressure of one or more tyres.

 The under-inflation detection system does not replace the need for vigilance on the part of the driver.

This system does not avoid the need to check the tyre pressures (including the spare wheel) every month as well as before a long journey.

Driving with under-inflated tyres impairs road holding, extends braking distances and causes premature tyre wear, particularly under arduous condition (high loading, high speed, long journey).

 Driving with under-inflated tyres increases fuel consumption.

 The inflation pressures defined for your vehicle can be found on the tyre pressure label.

For more information on the identification markings, refer to the corresponding section.

Tyre pressures should be checked when the tyres are "cold" (vehicle stopped for 1 hour or after a journey of less than 6 miles (10 km) at moderate speeds).

Otherwise (when hot), add 0.3 bar to the pressures shown on the label.

Under-inflation alert



This is given by fixed illumination of this warning lamp, accompanied by an audible signal and, depending on equipment, the display of a message.

- ☞ Reduce speed immediately, avoid excessive steering movements and sudden braking.
- ☞ Stop the vehicle as soon as it is safe to do so.

 The loss of pressure detected does not always cause visible bulging of the tyre.

Do not satisfy yourself with just a visual check.

☞ If you have a compressor, such as the one in the temporary puncture repair kit, check the pressures of the four tyres when cold.

☞ If it is not possible to make this check immediately, drive carefully at reduced speed.

or

☞ In the event of a puncture, use the temporary puncture repair kit or the spare wheel (depending on equipment).

 The alert is maintained until the system is reinitialised.

Reinitialisation

It is necessary to reinitialise the system every time one or more tyre pressures are adjusted, and after changing one or more wheels.

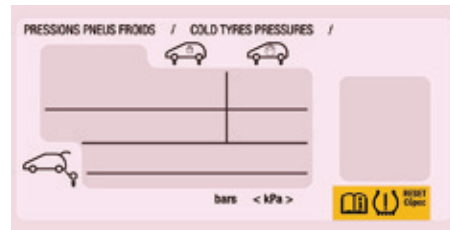

 Before reinitialising the system, ensure that the pressures of the four tyres are correct for the use of the vehicle and in line with the recommendations on the tyre pressure label.

The under-inflation alert can only be relied on if the reinitialisation of the system has been done with the pressures in the four tyres correctly adjusted.

The under-inflation detection system does not give a warning if a pressure is incorrect at the time of reinitialisation.

Reinitialisation of the system must be done with the **ignition on** and the vehicle stationary:

- in the vehicle configuration menu for vehicle fitted with a display screen,
- using the button on the dashboard, for vehicles without display screen.

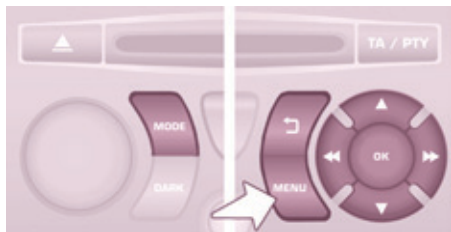

Screen A

- ☞ Press the **MENU** button for access to the main menu.
- ☞ Press the "▲" or "▼" button to select the menu **Veh config**, then confirm by pressing the **OK** button.
- ☞ Press the "▲" or "▼" button to select the "**Reinit inflat**", menu, then confirm by pressing the **OK** button.
A message is displayed to confirm the instruction.
- ☞ Confirm by pressing the **OK** button.

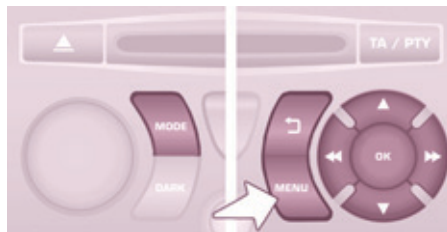

Screen C

- ☞ Press the **MENU** button for access to the main menu.
- ☞ Press the "▲" or "▼" button to select the "**Personalisation-configuration**" menu, then confirm by pressing the **OK** button.
- ☞ Press the "▲" or "▼" button to select the "**Define vehicle parameters**" menu, then confirm by pressing the **OK** button.
- ☞ Press the "▲" or "▼" button to select the "**Tyre pressures**" menu, then the "**Reinitialisation**" menu, then confirming by pressing the **OK** button.
A message confirms the reinitialisation.

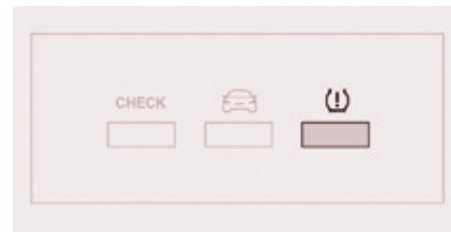

Touch screen

- ☞ Press the **MENU** button.
- ☞ Select the "**Driving**" menu.
- ☞ In the secondary page, select "**Under-inflation initialisation**".
A message is displayed to confirm the reinitialisation instruction.
- ☞ Select "**Yes**" or "**No**", then confirm.
A message confirms the reinitialisation.



Dashbord button

- ☞ Make a long press on this button.
A high tone audible signal confirms the reinitialisation.
- A low tone audible signal indicates that the reinitialisation was not completed.

The new pressure settings registered are considered to be reference values by the system.

i The under-inflation alert can only be relied on if the system has been reinitialised with all four tyres inflated to the correct pressures.

i **Snow chains**
The system does not have to be reinitialised after fitting or removing snow chains.

Operating fault



The flashing and then fixed illumination of the under-inflation warning lamp accompanied by illumination of the Service warning lamp indicates a fault with the system.

In this case, under-inflation monitoring of the tyres is no longer assured.

Have the system checked by a PEUGEOT dealer or a qualified workshop.

i Before doing anything to the system, the pressures of the four tyres must be checked and the system reinitialised.

SERVICE INDICATOR

This programme's service intervals according to the use of the vehicle.

Operation

A few moments after the ignition has been switched on, the spanner indicating a service operation comes on; the display for the total distance recorder gives (in round figures) the distance remaining before the next service.

The points at which a service is due are calculated from the last indicator zero reset.

The point at which a service is due is determined by two parameters:

- the distance travelled,
- the time which has elapsed since the last service.

i The distance remaining before the next service may be weighted by the time factor, depending on the type of driving.

More than 1 000 miles/km before the next service is due

Example: 4 800 miles/km remain before the next service is due. When the ignition is switched on and for a few seconds, the screen shows:



A few seconds after the ignition is switched on, the oil level is displayed (depending on version), then the total distance recorder resumes normal operation showing the total and trip distances.

Less than 1 000 miles/km before the next service is due

Each time the ignition is switched on and for a few seconds, the spanner flashes and the number of miles/kilometres remaining is displayed:



A few seconds after the ignition is switched on, the oil level is displayed (depending on version), then the total distance recorder resumes normal operation and the spanner remains on. This indicates that a service should be carried out shortly.

Service overdue



Each time the ignition is switched on and for a few seconds, the spanner flashes and the excess distance is displayed.

With the engine running the spanner remains on until the service has been carried out.

For BlueHDi Diesel versions, this alert is also accompanied by the fixed illumination of the Service warning lamp, on switching on the ignition.

i For BlueHDi Diesel versions, the spanner can also come on early, according to the level of deterioration of the engine oil. Deterioration of the engine oil depends on the conditions of use of the vehicle.

Zero reset

Your PEUGEOT dealer or a qualified workshop carries out this operation after each service.

However, if you carry out the service yourself, the re-set procedure is as follows:

- switch off the ignition,
- press and hold the trip recorder reset button,
- switch on the ignition.

The display begins a countdown.

When the display shows "**=0**", release the button; the spanner disappears.

 After this operation, if you wish to disconnect the battery, lock the vehicle and wait for at least five minutes, otherwise the zero re-set will not be registered.

Engine oil level indicator

Depending on your vehicle's engine, when the ignition is switched on, the engine oil level is indicated for a few seconds, after the service information.



Oil level correct



Low oil level

Flashing of "OIL", linked with the service warning lamp, accompanied by an

audible signal and a message in the screen, indicates a low oil level which could damage the engine.

If the low oil level is confirmed by a check using the dipstick, it is essential that the level is topped up.



Oil level gauge fault

Flashing of "OIL--" indicates a malfunction of the engine oil level

indicator. Contact a PEUGEOT dealer or a qualified workshop.



The level read will only be correct if the vehicle is on level ground and the engine has been off for more than 30 minutes.



Dipstick

A = maximum, never exceed this level as a surplus of oil may damage the engine.

Contact a PEUGEOT dealer or a qualified workshop without delay.

B = minimum, top up the level via the oil filler cap, using the grade of oil suited to your engine.

Trip recorder zero reset button



With the ignition on, press the button until the zeros appear.

Lighting dimmer



With the lighting on, press the button to vary the brightness of the instruments and controls.

When the lighting reaches the minimum (or maximum) setting, release the button then press it again to increase (or reduce) the brightness.

As soon as the lighting is of the required brightness, release the button.



STEERING WHEEL ADJUSTMENT

When the vehicle is stationary, release the steering wheel adjustment mechanism by pulling the lever.

Adjust the steering wheel for height and reach, then lock the mechanism by pushing the lever fully forward.

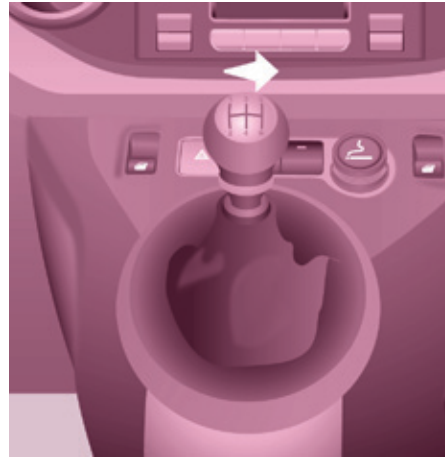

5-speed

MANUAL GEARBOX

To change gear easily, always depress the clutch pedal fully.

To prevent the mat from becoming caught under the pedal:

- ensure that the mat is positioned and secured correctly on the floor,
- never fit one mat on top of another.

When driving, avoid leaving your hand on the gear knob as the force exerted, even if slight, may wear the internal components of the gearbox over time.



6-speed

Engaging reverse gear

In the 6-speed configuration, raise the collar below the gear knob.

 The lever should be moved slowly to reduce noise.

To engage reverse gear, wait until the vehicle has come to a complete stop.

Changing into 5th or 6th gear

To engage the gear correctly, move the gear lever fully to the right.

Gearbox and steering wheel

50

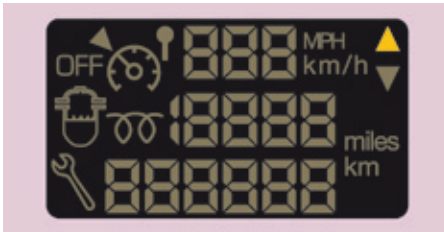

GEAR SHIFT INDICATOR

System which reduces fuel consumption by recommending the most appropriate gear.

With an electronic gearbox, the system is only active in manual mode.

Depending on the driving situation and your vehicle's equipment, the system may advise you to skip one (or more) gear(s). You can follow this instruction without engaging the intermediate gears.

The gear engagement recommendations must not be considered compulsory. This is because the configuration of the road, the traffic density and safety remain determining factors when choosing the best gear. Therefore, the driver remains responsible for deciding whether or not to follow the indications given.

This function cannot be deactivated.



The information appears in the instrument panel in the form of an arrow. It may be accompanied by a recommended gear.

i The system adapts its gear change recommendation according to the driving conditions (slope, load, ...) and the demands of the driver (power, acceleration, braking, ...).

The system never suggests:

- engaging first gear,
- engaging reverse gear.

6-SPEED ELECTRONIC GEARBOX



Mode selection

- automatic mode: gear selector in position **A**.
- manual mode: gear selector in position **M**.

 For safety:

It is only possible to come out of position **N** if the brake pedal is pressed.

The change from position **A** (driving in automatic mode) to position **M** (driving in manual mode) or vice versa can be made at any time. The warning lamp **A** goes off in the instrument panel.



Moving off

- To start the engine, the gear selector must be in position **N**.
- Press firmly on the brake pedal.
- Operate the starter.
- When the engine is running, place the gear selector on **R**, **A** or **M** as desired.
- Release the brake pedal and accelerate.

If the gear selector is not in position **N**, and/or if the brake pedal is not pressed, the engine will not start. Repeat the above procedure.

Reverse gear



Engaging reverse gear

Move the gear selector to **R**.

Only attempt to select reverse gear when the vehicle is stationary.

Neutral



Changing to neutral

Move the gear selector to **N**. If the vehicle is moving, do not select this position even momentarily.

Gearbox and steering wheel

Automatic mode



Changing to automatic mode

Move the gear selector to **A**.

The gearbox then operates in automatic mode, without any action on your part.

It constantly selects the gear that is best suited to the following conditions:

- driving style,
- road profile,
- optimum fuel consumption.

Manual mode



Changing to manual mode

Move the gear selector to **M**.

Changing gear



Pull on the "+" control paddle to change up.
Pull on the "-" control paddle to change down.

- If the vehicle stops or reduces speed (for example when approaching a stop sign), the gearbox changes down automatically, to first gear if needed.
- It is not necessary to release the accelerator completely during gear changes.
- A gear change instruction is accepted only if the engine speed permits.
- For safety reasons, depending on the engine speed, a change down may be performed automatically.

 In situations of high engine speeds (heavy acceleration), a change up will not occur unless the driver operates the electronic gearbox control paddle.

Acceleration

For optimum acceleration (e.g. to overtake another vehicle), simply press the pedal beyond the point of resistance at the end of its travel, by pressing down firmly.

Vehicle stationary, with the engine running

In the event of a prolonged stop with the engine running, the gearbox changes automatically to neutral **N**.

Stopping the vehicle

Before stopping the engine, put the gear selector in position **N**.

In all cases, it is essential to apply the parking brake. Check that the parking brake warning lamp is on in the instrument panel.

 Before doing anything in the engine compartment, check that the gear selector is in neutral **N**.

STOP & START

The Stop & Start system puts the engine temporarily on standby - STOP mode - during stops in the traffic (red lights, traffic jams, or other...).

The engine restarts automatically - START mode - as soon as you want to move off.

The restart takes place instantly, quickly and silently.

Perfect for urban use, the Stop & Start system reduces fuel consumption and exhaust emissions as well as the noise level when stationary.

Operation

Going into engine STOP mode

 The "ECO" warning lamp comes on in the instrument panel and the engine goes into standby:

- **with a manual gearbox**, at speeds below 12 mph (20 km/h), when you put the gear lever into neutral and release the clutch pedal,
- **with a 6-speed electronic gearbox**, at speeds below 5 mph (8 km/h), when you press the brake pedal or put the gear lever into position **N**.

If your vehicle is fitted with the system, a time counter calculates the sum of the periods in STOP mode during a journey. It rests itself to zero every time the ignition is switched on with the key.

 With a 6-speed electronic gearbox, for your comfort during parking manoeuvres, STOP mode is not available for a few seconds after coming out of reverse gear.

STOP mode does not affect the functionality of the vehicle, such as braking, power steering, for example.

 Never refuel with the engine in STOP mode; you must switch off the ignition with the key.

Special cases: STOP mode unavailable

STOP mode is not invoked when:

- the vehicle is on a steep slope (rising or falling),
- the driver's door is open,
- the driver's seat belt is not fastened,
- the vehicle has not exceeded 6 mph (10 km/h) since the last engine start using the key,
- the engine is needed to maintain a comfortable temperature in the passenger compartment,
- demisting is on,
- some special conditions (battery charge, engine temperature, braking assistance, ambient temperature...) where the engine is needed to assure control of a system.

 In this case, the "ECO" warning lamp flashes for a few seconds, then goes off.

This operation is perfectly normal.

Stop & Start

Going into engine START mode



The "ECO" warning lamp goes off and the engine starts:

- **with a manual gearbox**, when you fully depress the clutch pedal,
- **with a 6-speed electronic gearbox**:
 - gear lever in position **A** or **M**, when you release the brake pedal,
 - or gear lever in position **N** and the brake pedal released, when you move the gear lever to position **A** or **M**,
 - or when you engage reverse gear.

With a manual gearbox in STOP mode, if a gear is engaged without fully depressing the clutch pedal, a warning lamp comes on or a message is displayed asking you to depress the clutch pedal to restart the engine.

Special cases: START invoked automatically

For your safety and comfort, START is invoked automatically when:

- you open the driver's door,
- you unfasten the driver's seat belt,

- the speed of the vehicle exceeds 15 mph (25 km/h) with a manual gearbox or 7 mph (11 km/h) with the 6-speed electronic gearbox system,
- some special conditions (battery charge, engine temperature, braking assistance, ambient temperature...) where the engine is needed to assure control of a system.



In this case the "ECO" warning lamp flashes for few seconds, then goes off.

This operation is perfectly normal.

Deactivation

In certain circumstances, such as the need to maintain a comfortable temperature in the passenger compartment, it may be preferable to deactivate Stop & Start.



At any time, press the "ECO OFF" switch to deactivate the system.

This is confirmed by the switch warning lamp coming on accompanied by a message in the screen.

If the system has been deactivated in STOP mode, the engine restarts immediately.

Reactivation

Press the "ECO OFF" switch again. The system is active again; this is confirmed by the switch warning lamp going off and a message in the instrument panel.



The system is reactivated automatically at every new start using the key.

Operating fault



In the event of a malfunction with the system, the "ECO OFF" switch warning lamp flashes, then comes on continuously.

Have it checked by a PEUGEOT dealer or a qualified workshop.

In the event of a fault in STOP mode, the vehicle may stall. All of the warning lamps in the instrument panel come on. It is then necessary to switch off the ignition and start the engine again using the key.



This system requires a specific battery with a special specification and technology (reference numbers available from a PEUGEOT dealer or a qualified workshop).

Fitting a battery not listed by PEUGEOT introduces the risk of malfunction of the system.

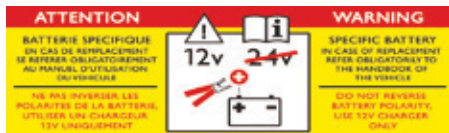

! The Stop & Start system requires a battery of specific characteristics. All work on this type of battery must be done only by a PEUGEOT dealer or a qualified workshop.
For more information on the 12 V battery, refer to "Battery" in section 8.

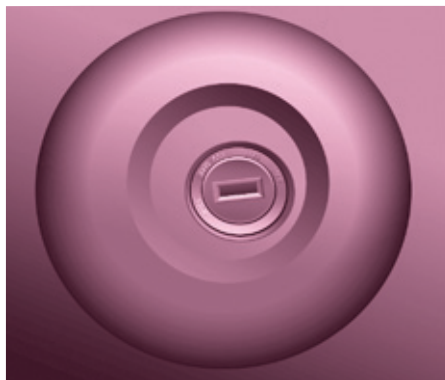

STARTING AND STOPPING

Opening the bonnet

Before doing anything under the bonnet, deactivate the Stop & Start system to avoid the risk of injury related to an automatic change to START mode.

Driving on flooded roads

Before driving through a flooded road, it is strongly recommended that you deactivate the Stop & Start system.
For more advice on driving, particularly on flooded roads, refer to the corresponding section.

Running and accessories position.

To unlock the steering, turn the steering wheel gently while turning the key, without forcing. In this position, certain accessories can be used.

Starting position.

The starter is operated, the engine turns over, release the key.

STOP position: steering lock.

The ignition is off. Turn the steering wheel until the steering locks. Remove the key.

Good practice when starting



Door or bonnet open warning lamp
If this comes on, a door or the bonnet is not closed correctly, check!



Diesel pre-heating warning lamp
If the temperature is high enough, the warning lamp comes on for less than one second, you can start without waiting.

In cold weather, wait for this warning lamp to go off then operate the starter (Starting position) until the engine starts.

Good practice when stopping

Minimise engine and gearbox wear

When switching off the ignition, let the engine run for a few seconds to allow the turbocharger (Diesel engine) to return to idle.

Do not press the accelerator when switching off the ignition.

There is no need to engage a gear after parking the vehicle.

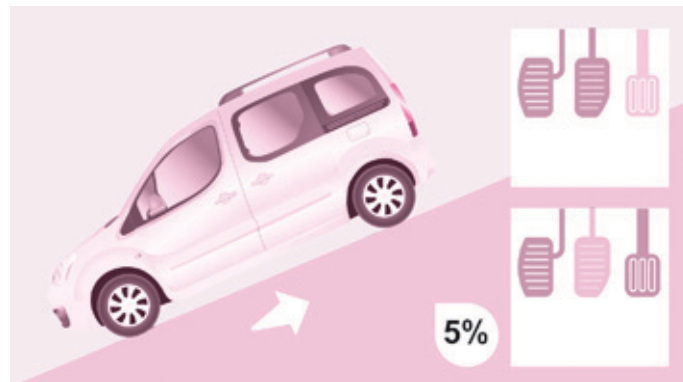
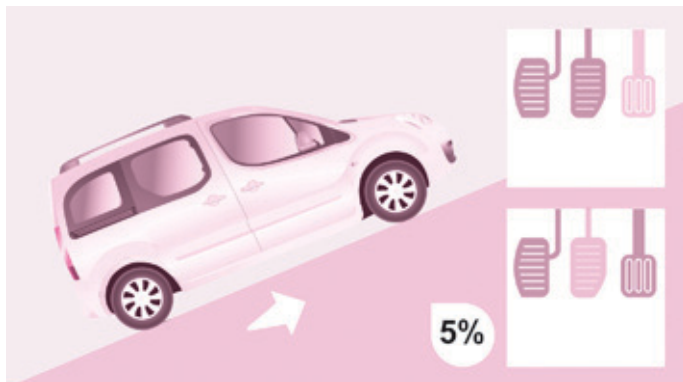

HILL START ASSIST

This system (also called HHC - Hill Holder Control), linked to the dynamic stability control system, makes hill starts easier and is activated in the following conditions:

- the vehicle must be stationary, engine running, foot on the brake,
- the gradient of the road must be steeper than 5%,
- uphill, the gearbox must be in neutral or in a gear other than reverse,
- downhill, reverse gear must be engaged.

The Hill Start Assist system is a driving aid. It is not an automatic vehicle parking function or an automatic parking brake.

Operation

With the brake pedal and clutch pedal pressed, from the time you release the brake pedal, without using the parking brake, you have approximately 2 seconds to move off before the vehicle starts to roll back.

During the moving off phase, the function is deactivated automatically, gradually releasing the braking pressure. During this phase, the characteristic noise of mechanical release of the brakes may be heard, indicating the imminent movement of the vehicle.

Hill start assist is deactivated in the following situations:

- when the clutch pedal is released,
- when the parking brake is applied,
- when the engine is switched off,
- when the engine stalls.

Operating fault



If a malfunction of the system occurs, this warning lamp comes on accompanied by an audible signal and confirmed by a message in the screen. Have the system checked by a PEUGEOT dealer or a qualified workshop.

DRIVING RECOMMENDATIONS

Observe the driving regulations and remain vigilant whatever the traffic conditions.

Pay close attention to the traffic and keep your hands on the wheel so that you are ready to react at any time to any eventuality.

As a safety precaution, the driver must only carry out actions requiring sustained attention when the vehicle is stationary.

On a long journey, a break every two hours is strongly recommended.

In difficult weather, drive smoothly, anticipate the need to brake and increase the distance from other vehicles.

Driving on flooded roads

We strongly advise against driving on flooded roads, as this could cause serious damage to the engine or gearbox, as well as to the electrical systems of your vehicle.

If you are obliged to drive through water:

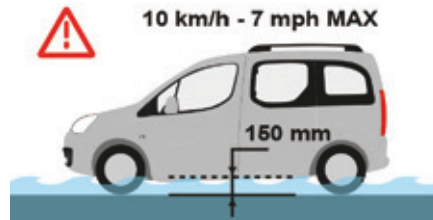

- check that the depth of water does not exceed 15 cm, taking account of waves that might be generated by other users,
- deactivate the Stop & Start system,
- drive as slowly as possible without stalling. In all cases, do not exceed 6 mph (10 km/h),
- do not stop and do not switch off the engine.

On leaving the flooded road, as soon as circumstances allow, make several light brake applications to dry the brake discs and pads.

If in doubt on the state of your vehicle, contact a PEUGEOT dealer or a qualified workshop.

Important!

- ⚠ Never drive with the parking brake applied - Risk of overheating and damage to the braking system!

Risk of fire!

As the exhaust system of your vehicle is very hot, even several minutes after switching off the engine, do not park or leave the engine running over areas where inflammable substances and materials are present: grass, leaves, etc.

- ⚠ Never leave a vehicle unsupervised with the engine running. If you have to leave your vehicle with the engine running, apply the parking brake and put the gearbox into neutral or position **N** or **P**, depending on the type of gearbox.

Steering mounted controls

58

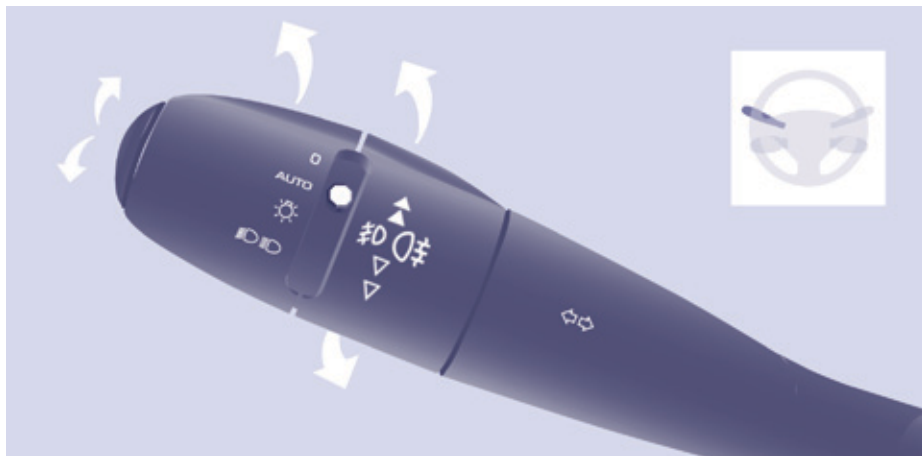

DIRECTION INDICATORS

Direction indicators



Left: downwards passing the point of resistance.

Right: upwards passing the point of resistance.

"Motorway" function

Press the control up or down to flash the corresponding direction indicator three times.

LIGHTING

Front and rear lighting



Selection is by turning this ring.



Checking by means of the indicator lamps in the instrument panel is described in the "Instruments and controls" section of chapter 3.



Lighting off



Automatic illumination of headlamps



Sidelamps



Dipped beam (green)

Main beam (blue)

Dipped beam/main beam change

Pull the stalk fully towards you.

Lighting-on audible warning

On switching off the ignition, all of the lamps turn off, except dipped beam if automatic guide-me-home lighting has been activated.



To activate the lighting control, turn this ring to the lighting off position "0" then to the selection of your choice.

On opening the driver's door, there is an audible warning if you have left the lighting on.

If the user does not operate any equipment for 30 minutes, the Economy mode engages to avoid discharging the battery. Electrical functions are put on standby and the battery warning lamp flashes.

Sidelamp operation is not affected by Economy mode.

 Refer to chapter 8, "Battery section".

Front and rear foglamps

They operate with the sidelamps and dipped beam headlamps.



Rotate this ring forwards to switch on and rearwards to switch off.

Their state is confirmed by the warning lamps in the instrument panel.



Front foglamps (green, 1st rotation of the ring forwards).



Rear foglamps (amber, 2nd rotation of the ring forwards).



To switch off the front and rear foglamps, turn the ring rearwards twice in succession.

In clear weather or in rain, both day and night, rear foglamps dazzle and their use is prohibited.

 Do not forget to switch them off when they are no longer needed.

Operation of the automatic illumination of headlamps switches off the rear foglamps, but the front foglamps remain on.

LED DAYTIME RUNNING LAMPS

On starting the vehicle, in daylight the LED daytime running lamps come on automatically.

If the sidelamps and headlamps are switched on manually or automatically, the daytime running lamps go off.

Programming

For countries where exterior lighting by day is not a legal requirement, you can activate or deactivate the function via the configuration menu.

Automatic illumination of headlamps

 The sidelamps and dipped beam headlamps switch on automatically if the light is poor, or during operation of the windscreen wipers. They switch off as soon as the light becomes bright enough or the windscreen wipers stop.

This function is not compatible with daytime running lamps.

 In foggy weather or in snow, the sunshine sensor may detect sufficient light.

 As a consequence, the lighting will not come on automatically. If necessary, you must switch on the dipped beam headlamps manually.

Do not cover the sunshine sensor located on the windscreen, behind the mirror. It is used for the automatic illumination of headlamps and for the automatic rain sensitive wipers.

Activation

Turn the ring to the **AUTO** position. The activation of this function is accompanied by a message in the screen.

Deactivation

Turn the ring forwards or rearwards. The deactivation of this function is accompanied by a message in the screen.

Steering mounted controls

The function is deactivated temporarily when you use the manual lighting control stalk.



If the sunshine sensor does not function correctly, the lighting comes on accompanied by the service warning lamp, an audible signal and a message in the screen.

Contact a PEUGEOT dealer or a qualified workshop.

Guide-me-home lighting

Keeping the dipped beam headlamps on temporarily with the ignition off, makes the driver's exit easier when the light is poor.

Manual operation

- With the ignition off, "flash" the headlamps within one minute after switching off the ignition.

The guide-me-home lighting switches off automatically after a set time.

Automatic operation



Activate the function via the vehicle configuration menu.



Refer to chapter 10, "Screen menu map" section.



CORNERING LIGHTING

With dipped or main beam headlamps, this function makes use of the beam from a front foglamp to illuminate the inside of a bend, when the vehicle speed is below 25 mph (approximately 40 km/h) (urban driving, winding road, intersections, parking manoeuvres...).

Switching on

This function starts:

- when the corresponding direction indicator is switched on,
- or
- from a certain angle of rotation of the steering wheel.

Switching off

The system does not operate:

- below a certain angle of rotation of the steering wheel,
- above 25 mph (40 km/h),
- when reverse gear is engaged.

Programming

The system is activated or deactivated in the vehicle configuration menu.

The system is activated by default.

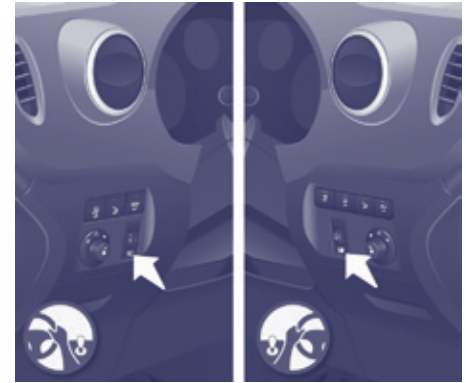

HEADLAMP BEAM

The beam setting must be adjusted to suit the load in the vehicle.

0 - No load.

1 - Partial load.

2 - Average load.

3 - Maximum authorised load.

Initial setting is position 0.

i Travelling abroad

If using your vehicle in a country that drives on the other side of the road, the headlamps must be adjusted to avoid dazzling on-coming drivers.

Contact a PEUGEOT dealer or a qualified workshop.

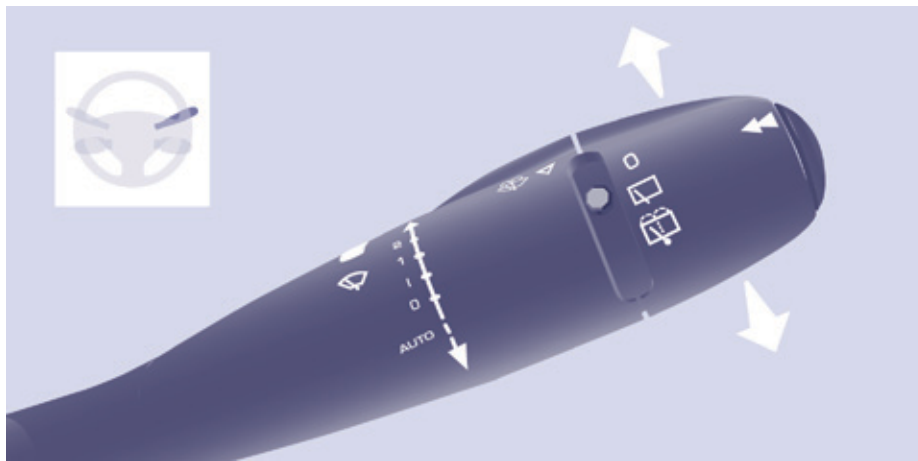

WIPERS

Manual wiping

- 2 Fast wipe (heavy rain).
- 1 Normal wipe (moderate rain).
- 1 Intermittent wipe.
- 0 Off.
- ↓ Single wipe
(press downwards).

In the Intermittent position, the wiping speed is in proportion to the vehicle speed.

Whenever the ignition has been switched off for more than one minute, with the windscreen wiper stalk in position 2, 1 or 1, the stalk must be reactivated.

- Move the stalk to any position.
- Return it to the desired position.

Automatic wipers



Do not cover the rain sensor, located in the centre of the windscreen, behind the mirror.

In the **AUTO** position, the windscreen wipers operate automatically and adapt their speed to the intensity of the rainfall.

When not in **AUTO** mode, for the other positions, refer to the manual windscreen wipers section.

Activation

Press the control downwards. Activation of the function is accompanied by a message in the screen.

The automatic rain sensitive windscreen wipers function must be reactivated by pressing the stalk downwards, if the ignition has been switched off for more than one minute.

Deactivation

Place the windscreen wipers stalk in position 1, 1 or 2.

Deactivation of the function is accompanied by a message in the screen.

In the event of malfunction of the automatic windscreen wipers, the windscreen wipers will operate in intermittent mode.

Contact a PEUGEOT dealer or a qualified workshop to have the system checked.

! When using an automatic car wash, switch off the ignition to avoid triggering the automatic wiping.

In winter, it is advisable to wait for the windscreen to completely clear of ice before operating the automatic wipers.

Steering mounted controls

Screenwash

62

Pull the stalk towards you, the wash-wipe is accompanied by a timed sweep of the wipers.

 To top up the level, refer to the "Levels" section of chapter 7.

Special position of the windscreen wipers

In the minute following switching off of the ignition, any action on the stalk positions the wipers against the windscreen uprights.

This action enables you to position the wiper blades for winter parking, cleaning or replacement.

 Refer to the "Changing a windscreen wiper blade" section of chapter 8.

To park the wipers in their normal position after this has been done, switch on the ignition and move the stalk.

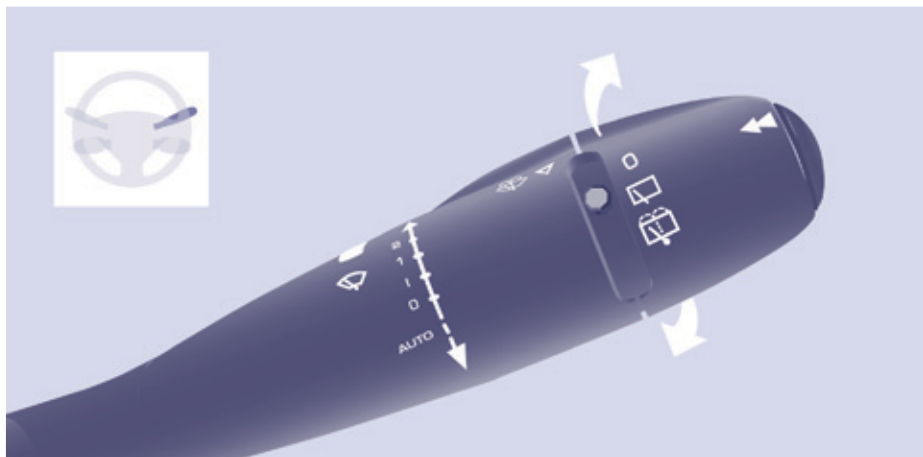

Rear wiper



Turn the ring to the first position.

Rear screenwash



Turn the ring past the first position: the rear screenwash then the rear wiper operates for a fixed time.

 In winter, in the event of a considerable amount of snow or ice, switch on the heated rear screen. Once the screen is clear, remove the snow or ice which has accumulated on the rear wiper blade. You can then operate the rear windscreen wiper.

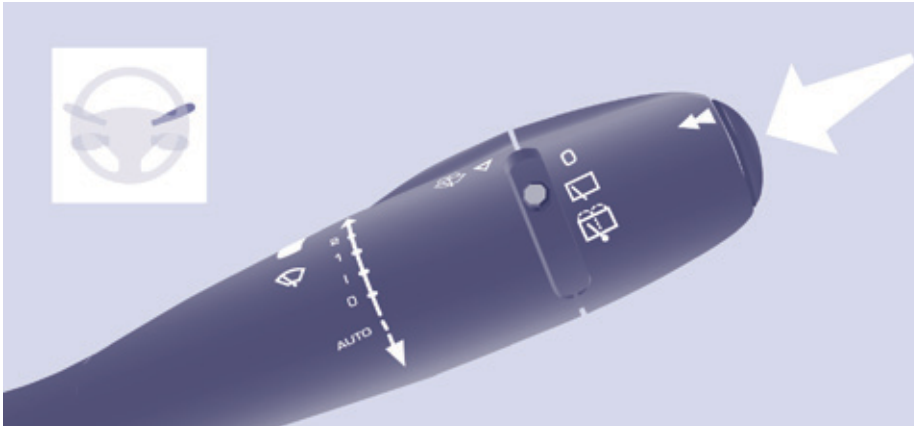

TRIP COMPUTER

Each press of the button, located at the end of the wiper stalk, displays the different trip computer information in turn, depending on the screen.

The "vehicle" tab with the range, current fuel consumption and the remaining distance to run.

The "1" tab (trip 1) with the average speed, the average fuel consumption and the distance travelled in trip "1".

The "2" tab (trip 2) with the same information for a 2nd trip.

Reset

When the required trip is displayed, press the control for more than two seconds.

A few definitions

Range: displays the distance which can travelled with the remaining fuel detected in the tank, based on the average consumption over the last few miles (kilometres).

This displayed value may vary significantly following a change in the vehicle speed or the relief of the route.

When the range falls below 20 miles (30 km), dashes are displayed. After filling with at least 10 litres of fuel, the range is recalculated and is displayed when it exceeds 60 miles (100 km).

If, whilst driving, dashes are displayed continuously in place of the digits, contact a PEUGEOT dealer.

Current fuel consumption: only calculated and displayed above 20 mph (30 km/h).

Average fuel consumption: this is the average fuel consumption since the last trip computer zero reset.

Distance travelled: calculated since the last trip computer zero reset.

Distance remaining to the destination: calculated with reference to the final destination, entered by the user. If guidance is activated, the navigation system calculates it as a current value.

Average speed: this is the average speed calculated since the last trip computer zero reset (ignition on).

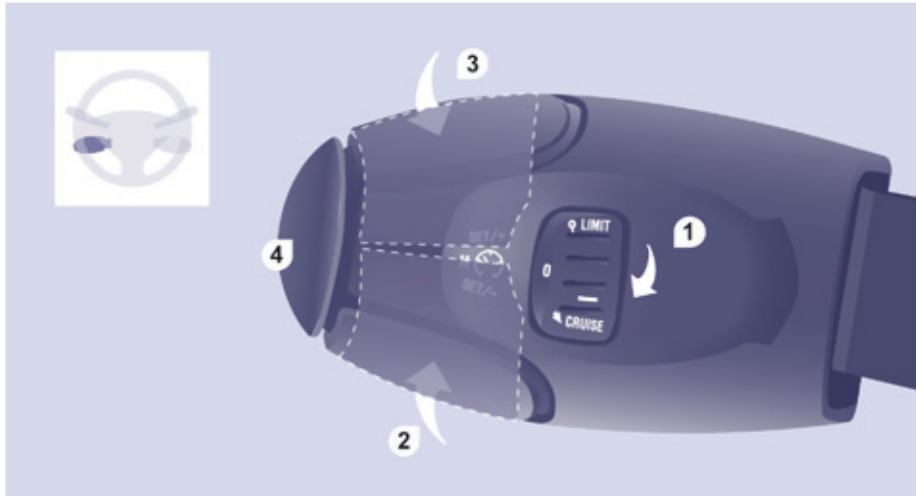

CRUISE CONTROL

"CRUISE"

1. Cruise control mode On / Off.
2. Reduce cruise speed setting.
3. Increase cruise speed setting.
4. Pause / Resume cruise control.

"This is the speed at which the driver wishes to drive".

This aid to driving in free-flowing traffic enables the vehicle to maintain the speed programmed by the driver, unless a steep gradient makes this impossible.

For the system to be programmed or activated, the vehicle speed must be greater than 25 mph (40 km/h) with 4th gear or higher engaged.

The state of the cruise control system can be seen in the instrument panel together with the the programmed speed setting.



Function selected, display of the "Cruise Control" symbol.



Function off, **OFF**.



Function on.



Vehicle speed above, the programmed speed flashes.



Operating fault detected, **OFF** - the dashes flash.



Selecting the function

- Place the switch in the **CRUISE** position. The cruise control is selected but is not yet active and no speed has been programmed.

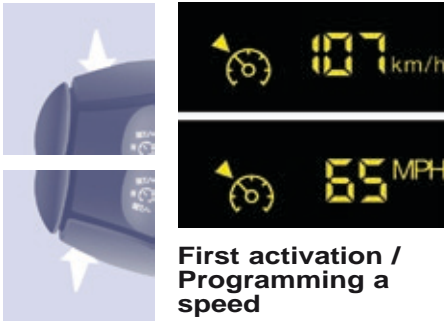

First activation / Programming a speed

- Reach the chosen speed by pressing the accelerator.
- Press the **SET -** or **SET +** button. This programmes/activates the speed setting and the vehicle will maintain this speed.

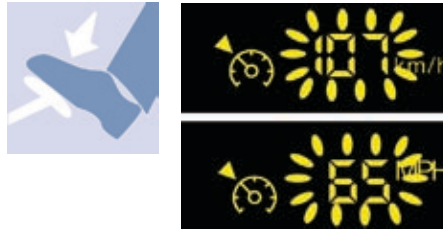

Temporarily exceeding the speed setting

It is possible to **accelerate** and drive momentarily at a speed greater than the programmed speed setting. The value programmed flashes.

When the accelerator pedal is released, the vehicle will return to the programmed speed.



Deactivation (off)

- Press this button or the brake or clutch pedal.



Reactivation

- Following deactivation of the cruise control, press this button. Your vehicle will return to the last programmed speed. Alternatively, you can repeat the "first activation" procedure.

Steering mounted controls

99

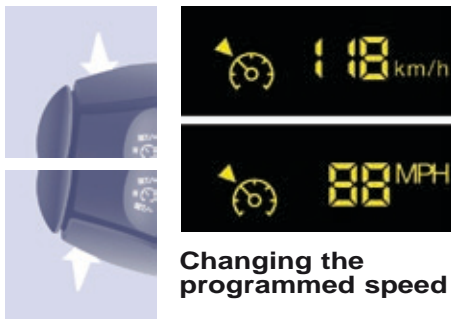

Changing the programmed speed

There are two methods of memorising a speed **higher** than the previous one:

Without using the accelerator

- Press the **SET +** button.

A brief press increases the speed by 1 mph (km/h).
A maintained press increases the speed in steps of 5 mph (km/h).

Using the accelerator

- Exceed the memorised speed until the speed required is reached,
- Press the **SET +** or **SET -** button.

To memorise a speed **lower** than the previous one:

- Press the **SET -** button.

A brief press decreases the speed by 1 mph (km/h).

A maintained press decreases the speed in steps of 5 mph (km/h).



Switching the system off

- Place the dial in position **0** or switch off the ignition to switch everything off.

Cancelling the programmed speed setting

When the vehicle becomes stationary, after switching off the ignition, the system no longer memorises a speed.



Operating fault

The programmed speed setting is cleared and replaced by three dashes. Contact a PEUGEOT dealer or a qualified workshop to have the system checked.

Good practice

When changing the programmed speed setting by means of a maintained press, pay attention as the speed can increase or decrease rapidly.

Do not use the cruise control on slippery roads or in heavy traffic.

In the event of a steep slope, the cruise control cannot prevent the vehicle from exceeding the programmed speed setting.

In any event, the cruise control cannot replace the need to observe the speed limits and the need for vigilance on the part of the driver.

It is advisable to keep your feet near the pedals.

To avoid any jamming under the pedals:

- ensure that the mat and its fixings on the floor are positioned correctly,
- never place one mat on top of another.

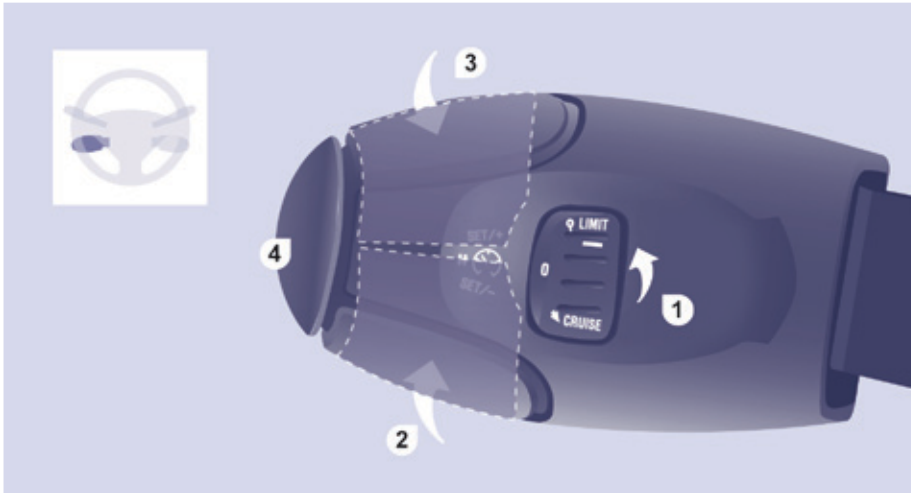

SPEED LIMITER

"LIMIT"

1. Limiter mode On / Off.
2. Reduce programmed speed setting.
3. Increase programmed speed setting.
4. Speed limiter On / Pause.

"This is the selected speed which the driver does not wish to exceed".

This selection is made with the engine running while stationary or with the vehicle moving. The minimum speed which can be programmed is 20 mph (30 km/h).

The speed of the vehicle responds to the pressure of the driver's foot, up to the the accelerator pedal's point of resistance, which indicates that the programmed speed has been reached. However, pressing the pedal beyond this point of resistance to the floor allows the programmed speed to be exceeded. To resume use of the limiter, simply reduce the pressure on the accelerator pedal gradually and return to a speed below that programmed.

Adjustments can be carried out when stationary, with the engine running, or with the vehicle moving.

This speed limiter shows the function selection status in the instrument panel and displays the programmed speed:



Function selected, displaying of the "Speed Limiter" symbol.



Function off, last programmed speed - OFF.



Function on.



Vehicle speed above, the programmed speed setting is displayed flashing.



Operating fault detected, OFF - the dashes flash.



Steering mounted controls

68



Selecting the function

- Place the switch in the **LIMIT** position. The limiter is selected but is not yet active. The screen indicates the last programmed speed setting.



Programming a speed setting

A speed can be programmed without activating the limiter but with the engine running.

To memorise a speed **higher** than the previous one:

- Press the **SET +** button.

A brief press increases the speed by 1 mph (km/h).

A maintained press increases the speed in steps of 5 mph (km/h).

To memorise a speed **lower** than the previous one.

- Press the **SET -** button.

A brief press decreases the speed by 1 mph (km/h).

A maintained press decreases the speed in steps of 5 mph (km/h).

On / Off

Pressing this button once activates the limiter, pressing the button again deactivates it (**OFF**).



Exceeding the programmed speed

Pressing the accelerator pedal in order to exceed the programmed speed will have no effect unless you press the pedal **firmly** beyond the **point of resistance**.

The limiter is deactivated temporarily and the programmed speed flashes accompanied by an audible signal.

To return to the limiter function, reduce your speed to below the programmed speed.

Flashing of the speed setting

The speed setting flashes:

- following forcing of the accelerator point of resistance,
- when the limiter cannot prevent an increase in the vehicle speed due to the profile of the road or on a steep descent,
- in the event of sharp acceleration.



Switching the function off

- Place the switch in position **0** or switch off the ignition to switch the system off.

The last programmed speed remains in the memory.



Operating fault

The programmed speed is cleared then replaced by three dashes.

Contact a PEUGEOT dealer or a qualified workshop to have the system checked.

Good practice

In any event, the speed limiter cannot replace the need to observe speed limits, nor can it replace the need for vigilance on the part of the driver.

Always pay attention to the profile of the road and sharp acceleration and stay in complete control of your vehicle.

To avoid any jamming under the pedals:

- ensure that the mat and its fixings on the floor are positioned correctly,
- never place one mat on top of another.



Heating



Manual air conditioning

VENTILATION

Temperature

Control positioned:



in the blue zone, provides ambient air,



in the red zone, provides heating of the passenger compartment.

Air flow



The speed of the blown air at the vents varies from 1 to the fastest 4. Position 0 switches it off.

Adjust this control in order to attain the desired comfort level.

Air distribution

The air supply distribution is determined by the following symbols:



the side vents and the central vents,



the footwells,



the windscreen and the footwells,



the windscreen.



the air distribution can be modulated by placing the control in the intermediate positions, marked "•".

Intake of exterior air



The LED in the button is off. This is the preferred operating position.

Recirculation of interior air



The LED in the button is on. Recirculation temporarily prevents exterior odours and smoke from entering the passenger compartment.

Used with the setting of the fan speed (from 1 to 4), recirculation enables you to attain the desired comfort level more quickly with both hot or cold settings.

This position should only be temporary. When your desired comfort level has been reached, return to the intake of exterior air position to permit renewal of the air in the passenger compartment and avoid misting. This is the preferred operating mode.

Air conditioning A/C

The air conditioning can only operate with the engine running.



Pressing the button starts the air conditioning system, the LED is on. Pressing the button again switches the function off and the LED goes off.

The air conditioning does not operate if the fan speed is set to 0.



DIGITAL AIR CONDITIONING SEPARATE SETTINGS FOR DRIVER AND PASSENGER

Good practice

For maximum cooling or heating of the passenger compartment, it is possible to exceed the value 15 by turning until LO is displayed or the value 27 by turning until HI is displayed.

On entering the vehicle, the inside temperature may be much colder (or warmer) than is comfortable. There is no advantage in changing the value displayed in order to quickly reach the level of comfort required. The system will use its maximum performance to reach the comfort value set.

Automatic operation

AUTO comfort programme

This is the normal air conditioning system operating mode.

Press this button, the **AUTO** symbol is displayed. The system controls the distribution, the flow and the intake of air to guarantee comfort and a sufficient circulation of air in the passenger compartment according to the comfort value set. No further action on your part is required.

Air flow will increase gradually when the engine is cold, to prevent excessive distribution of cold air.

For your comfort, the settings are stored when the ignition is switched off and are reinstated the next time the vehicle is started.

The automatic function will no longer be maintained if you change a setting manually (AUTO is cleared).

Driver or passenger side comfort value

The value indicated in the screen corresponds to a level of comfort and not a temperature in degrees Celsius or Fahrenheit.



Turn this control to the left or to the right to decrease or increase the value. A setting around the value 21 provides optimum comfort. However, depending on your requirements, a setting between 18 and 24 is usual.



Do not cover the sunshine sensor located on the dashboard.

Manual operation

You can, according to your requirements, make a different selection from that offered by the system by changing a setting. The other functions will still be controlled automatically. Pressing the **AUTO** button restores fully automatic operation.



Air distribution

Pressing this button several times in succession directs the air flow towards:

- the windscreen,
- the windscreen and footwells,
- the footwells,
- the side vents, central vents and footwells,
- the side vents and central vents.



Air flow

Press the **small fan** button to reduce the flow or the **large fan** button to increase the flow.

On the display, the blades of the fan fill when the flow is increased.



Deactivating the system

Press the air flow **small fan** button until the fan symbol disappears from the display.

This action deactivates all of the system's functions, with the exception of the air recirculation and rear screen demisting (if fitted on your vehicle). Your comfort setting is no longer maintained and is switched off.

For your comfort, do not deactivate the system for long periods.



Pressing the **large fan** button or the **AUTO** button reactivates the system with the values set before it was deactivated.



Intake of exterior air / Recirculation of interior air

Press this button to recirculate the interior air. The recirculation symbol is displayed.

Recirculation prevents exterior odours and smoke from entering the passenger compartment. Avoid prolonged operation in interior air recirculation mode (risk of condensation, odour and humidity). Pressing this button again activates the intake of exterior air.



Switching the air conditioning On / Off









Press this button, the **A/C** symbol is displayed and the air conditioning is activated.

Pressing this button again switches off the air conditioning.



The ventilation outlet, located in the glove box, diffuses cool air (if the air conditioning is on) regardless of the reference temperature requested in the passenger compartment and regardless of the exterior temperature.

Recommended settings for air conditioning

If I require...	Air distribution	Temperature	Air flow	Air recirculation	A/C
Heating					-
Cooling					A/C
Demisting Defrosting					

AUTO

With automatic digital air conditioning, operation in **AUTO** mode is recommended, irrespective of the requirement.



Remember to switch it off when the ambient air suits your requirements.



DEMISTING AND DEFROSTING

Manual mode



Turn the control to this air distribution setting.



Turn the control to this temperature setting.



Increase the air flow setting.



Press the air conditioning button.



Returning to exterior air intake open permits renewal of the air in the passenger compartment (LED off).

Demisting the rear screen and/or mirrors



Pressing this button, with the engine running, activates the rapid demisting - defrosting of the rear screen and/or electric mirrors.

This function switches off:

- when the button is pressed,
- when the engine is switched off,
- automatically to prevent excessive energy consumption.



DEMISTING AND DEFROSTING

Automatic mode: visibility programme

The comfort programme (AUTO) may not be sufficient to quickly demist or defrost the windows (humidity, several passengers, ice).

In this case, select the visibility programme. The visibility programme indicator comes on.

It activates the air conditioning, the air flow and provides optimum distribution of the ventilation to the windscreen and side windows.

It deactivates the air recirculation.

GOOD PRACTICE

Vents

"Leave them open"

For optimum distribution and diffusion of hot or cool air in the passenger compartment, there are adjustable central and side vents which can be directed sideways (right or left) or vertically (up or down). For your comfort while driving, do not close them and direct the flow of air towards the windows instead.

Air vents in the footwells and directed towards the windscreen complete the equipment.

Do not block the vents located at the windscreen or the air extractor located in the boot.

Dust filter, odour filter (activated carbon)

This filter traps certain dust and limits odours.

Ensure that this filter is in good condition and have all of the filter elements replaced regularly.



Refer to the "Checks" section of chapter 7.

Air conditioning

In all seasons, the air conditioning should only be used with the windows closed. However, if the interior temperature remains high after a prolonged period parked in the sun, first ventilate the passenger compartment for a few minutes.

Use the AUTO mode as much as possible as it permits optimised control of all of the functions: air flow, passenger compartment comfort temperature, air distribution, air intake mode or air recirculation in the passenger compartment.

Operate the air conditioning system for 5 to 10 minutes, once or twice a month, to keep it in good working order.

If the system does not produce cold air, do not use it and contact a PEUGEOT dealer or a qualified workshop.

It is normal that the condensation created by the air conditioning system results in a flow of water which may form a puddle under the vehicle when parked.



FRONT SEATS

The following adjustments are available:



Forwards/backwards

Lift the bar and slide the seat forwards or backwards.



Seat height (driver)

To raise the seat, pull the control upwards then take your weight off the seat cushion.

To lower the seat, pull the control upwards then push on the seat cushion.



Seat backrest angle

With your back pressed against the seat backrest, move the lever forwards and set the required angle.





Head restraint height

To raise the head restraint, slide it vertically upwards.

To lower the head restraint, press the button and slide the head restraint vertically downwards.

The adjustment is correct when the upper edge of the head restraint is level with the top of the head.

To remove the head restraint, press the button and pull the head restraint upwards.

To re-install the head restraint, engage the rods in the holes making sure they are aligned with the seat back.

 Never drive with the head restraints removed; they must be in place and correctly adjusted.

Adjustable armrest

To access the vertical position, raise the armrest until it locks.

Lower the armrest to return it to a position for use.

To remove the armrest, press the release button from the vertical position and move aside the armrest.

To put the armrest back in place, clip it in the vertical position.

If the vehicle is fitted with the additional console and an armrest, to fold the passenger seat to the table position remove the console or the armrest.



Front heated seats control

Each front seat may be fitted with a control located on the side part of the cushion.

Press to switch on the cushion heating.

Press again to switch it off.

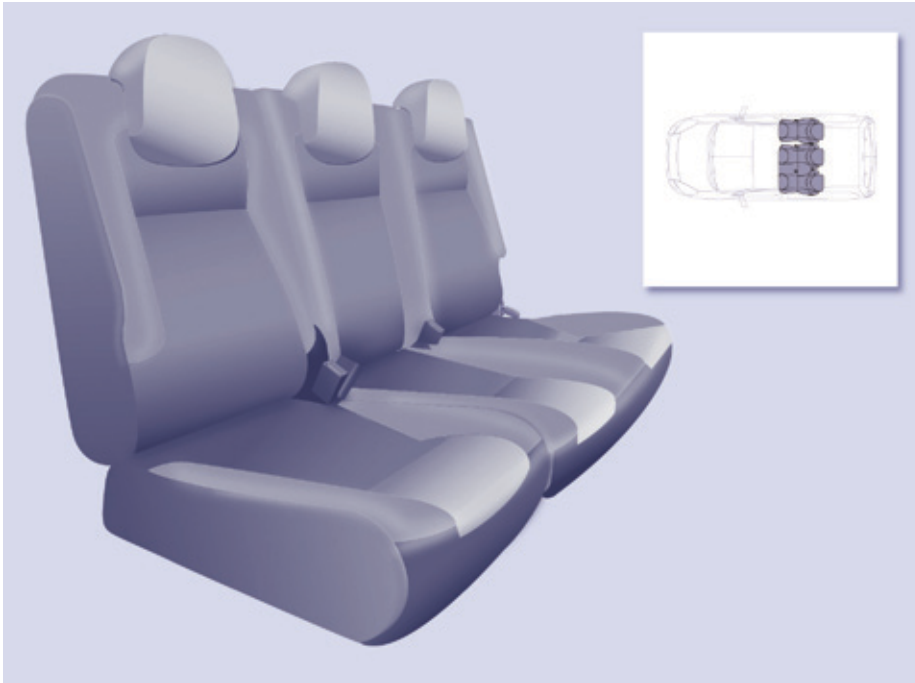

REAR BENCH SEAT

The 1/3 - 2/3 split rear bench seat is fitted with "comma" shape head restraints.

Each 1/3 - 2/3 section can be fully folded, then removed individually.

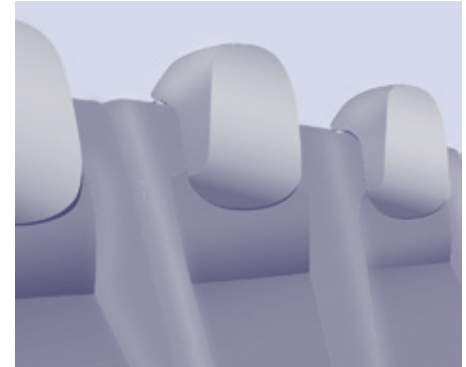

Head restraint

High position: lift and raise the head restraint.

Low position: press on the head restraint to lower it.

To remove the head restraint, after raising it press the tab and lift the head restraint.

To install the head restraint, engage the rods of the head restraint in the holes keeping it in line with the seat back.

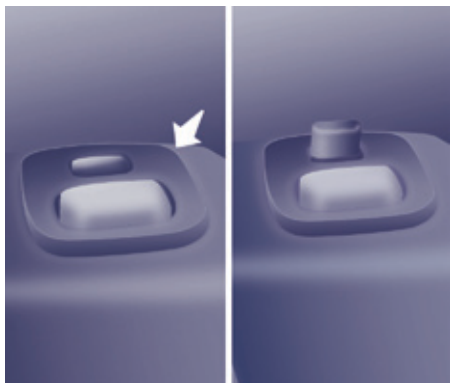

Fully folded position

Example of operations for the 1/3 section. They are identical for the 2/3 section.

- Place the head restraints in the low position.
- If necessary, move the front seats forward.
- Press the grey control located on the upper part of the seat backrest.
- Fold the seat backrest onto the seat cushion.

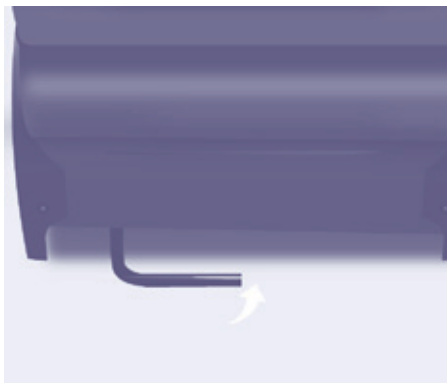

- Raise the grey control bar, located at the rear of the seat cushion.



Putting back in place

Tilt the entire seat rearwards until it locks into place.

Raise the seat backrest.

The seat is locked correctly when the control (at the top of the seat back) is no longer visible.

- i** Check that the seat is locked on the floor securely when it is returned to the sitting position.



- Tilt the entire seat forward.

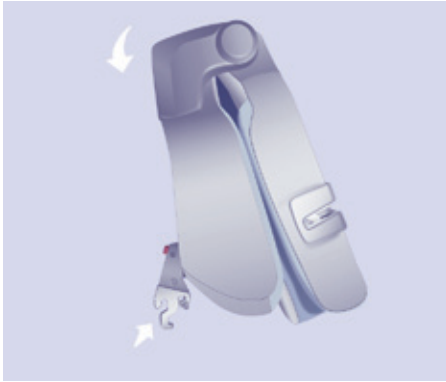

Removing the bench seat

- If necessary, move the front seats forward.
- Place the bench seat (1/3 section and/or 2/3 section) in the fully folded position.

+ Refer to the "Fully folded position", described previously.

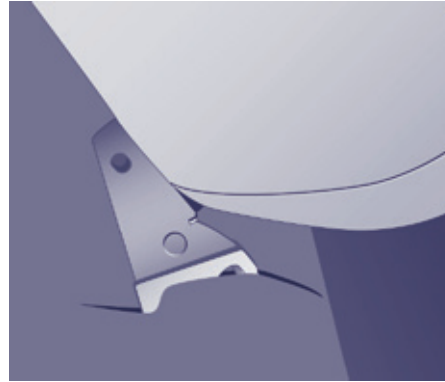

- Tilt the entire seat rearwards by approximately 45°.
- Lift the bench seat **vertically** to the limit of the anchorages.
- Straighten bench seat by tilting it forwards then lift it.

Refitting the bench seat

- Offer up the bench seat (1/3 section and/or 2/3 section) vertically.
- Place the hooks between the two bars.
- Fold the bench seat rearwards.

+ To return the bench seat (1/3 section and/or 2/3 section) to the "passenger carrying" position, refer to the "Fully folded position" described previously.

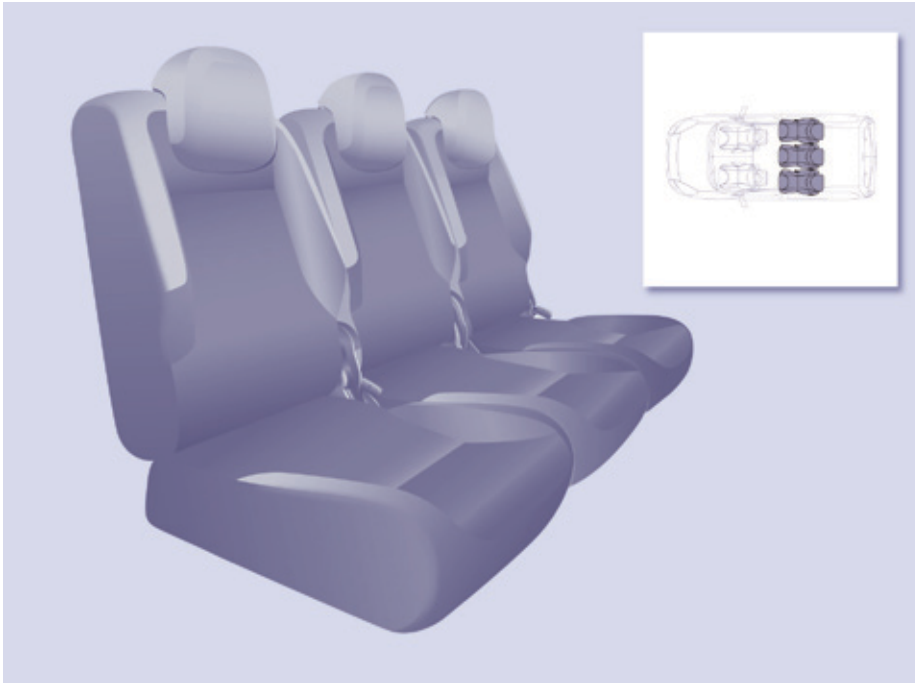

REAR SEATS (5 SEAT VERSION)

The three independent rear seats are fitted with "comma" shape head restraints.

The back of the centre seat, folded onto the seat cushion, has a shell which serves as a table with cup holder.

Each seat can be removed individually.

Each time a seat is returned to the sitting position or after removing then refitting a seat, check that it is locked on the floor securely.

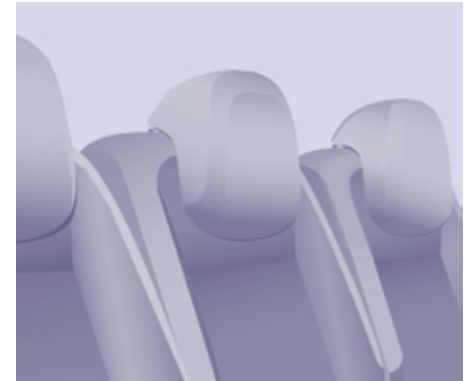

Head restraint

High position: lift and raise the head restraint.

Low position: press on the head restraint to lower it.

To remove the head restraint, after raising it press the tab and lift the head restraint.

To install the head restraint, engage the rods of the head restraint in the holes keeping it in line with the seat back.

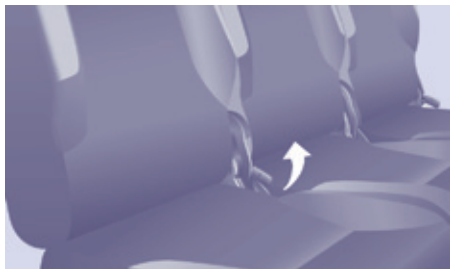

Adjusting the angle of the seat backrest

- Operate the control and adjust the angle of the seat backrest.



Placing the seat back in the table position

- Pull the control to fold the seat back onto the seat cushion.

Do not place hard or heavy objects on the table. They could become dangerous projectiles in the event of sharp braking or impact.

Returning the seat back to the sitting position

- Release the seat back by pulling the control, then return it to its original position.

When returning the seat backrest to the sitting position, ensure that it is locked securely.



Placing the seat in the fully folded position

- Pull the control to place the seat back in the table position.
- Raise the bar located behind the seat to release the rear anchoring points.
- Tilt the entire seat forwards, until it locks.



Returning the seat to its original position

- Push the red control.
- Fold back the seat to fix the rear anchoring points.
- Raise the seat backrest by pulling the control.
- Check that the seat has correctly locked into place.

! Before unfolding the seat, check that no object is obstructing the anchorage points or preventing correct locking of the seats.



Removing the seat

- If necessary, move the front seats forward and lower the head restraint.
- Place the seat in the fully folded position.

+ Refer to the "Fully folded position" described previously.

- Press the red lever to release the front feet.
- Tilt the entire seat rearwards by approximately 45° without releasing the lever.
- Release the lever.
- Lift the seat **vertically** to the limit of the anchorages.
- Straighten the seat by tilting it forwards then lift it.



Refitting the seat

- Tilt the seat forward by 45°.
- Place the hooks between the two bars.
- Fold back the seat to fix the rear anchoring points.
- Pull the control to return the seat back to its initial position.
- Raise the head restraint.

! Before unfolding the seat, check that no object is obstructing the anchorage points or preventing correct locking of the seats.

Good practice

Following the various operations:

- do not remove a head restraint without storing it and fix it to a support,
- ensure that the passengers can always access the seat belts and fasten them easily,
- passengers must never take their seat without adjusting and fastening their seat belt.



REAR SEATS (7 SEAT VERSION)

The seats of row 2 and row 3 are independent and adjustable.

Each seat can be removed and must be replaced in the specified position, indicated by a symbol on its label.

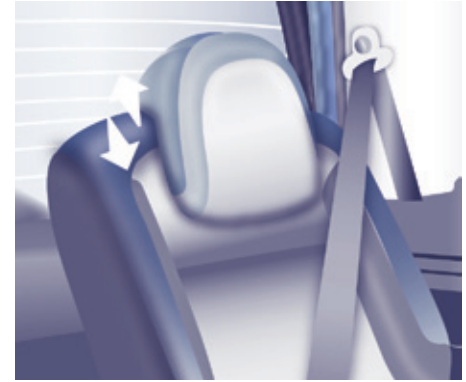

Head restraint

This is of the "comma" shape type.

High position: press the tab, lift and raise the head restraint.

Low position: push the tab and press the top of the head restraint to lower it.

To remove the head restraint: place it in the high position, lift it, then remove it.

Store it inside the vehicle, securing it firmly.

To install the head restraint: engage the rods of the head restraint in the holes keeping it in line with the seat back.

Seats

88

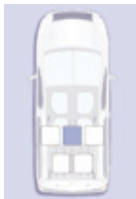

Types of Row 2 seat

Left-hand outer seat

Centre seat

Right-hand outer seat

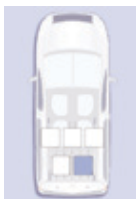

Types of Row 3 seat

Left-hand outer seat

Right-hand outer seat

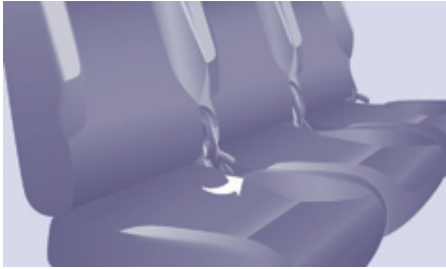

Row 2 seat adjustments

Adjusting the angle of the seat backrest

- Operate the control and adjust the angle.



Placing the seat backrest in the table position

- Lower the head restraint fully.
- Operate the control to fold the seat back onto the seat cushion.

Returning the seat backrest to the sitting position

- Release the seat backrest by pulling the control, then return it to its original position.
- Ensure that it has correctly locked into place.



Placing the seat in the fully folded position

- Place the seat in the table position.
- Pull the red strap, located behind the seat, to release the feet of the seat from their anchorage on the floor.
- Tilt the entire seat forwards.



Returning the seat to its original position

- Unfold the entire seat.

i Before folding the seat, ensure that:

- in row 3, no passenger's foot is at one of the seat anchorages on the floor,
- the seat is locked securely on the floor,
- the seat belt is available for the passenger.



Row 3 seat adjustments

Placing the seat backrest in the table position

- Lower the head restraint fully.
- Operate the control to fold the seat backrest onto the seat cushion.

Returning the seat backrest to the sitting position

- Release the seat backrest by pulling the control, then return it to its original position.
- Check that it has correctly locked in place.



Placing the seat in the fully folded position

- Place the seat in the table position.
- Raise the bar fitted with a red strap, located behind the seat, to release feet of the seat from their anchorage on the floor.
- Tilt the entire seat forwards.

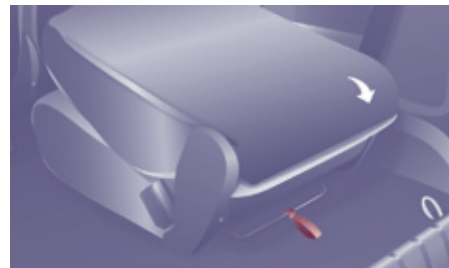

Returning the seat to its original position

- Push the red control.
- Unfold the entire seat.



Ensure that:

- the seat is locked securely on the floor,
- the seat belt is available for the passenger.



Entering, exiting from Row 3

Entering

- Place the row 2 seat in the table position.



- i** Before folding it back, ensure that the feet of the passenger in row 3 are not obstructing the row 2 seat anchoring points.

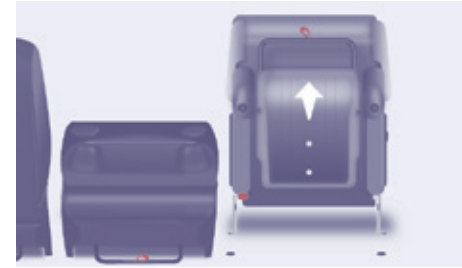

- Pull the red strap to place the seat in the fully folded position.
- Tilt the entire seat forwards.



- Tilt it to the fully folded position to allow access.



Exiting

- Lower the head restraint fully.
- Operate the yellow control, located on the back of the row 2 seat backrest.
- Fold the seat backrest to the table position.

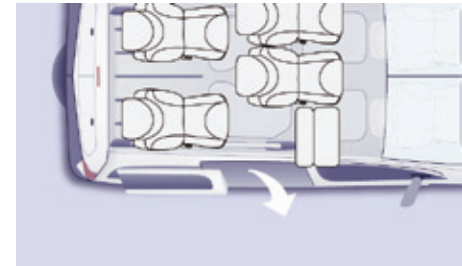

- Exit via the side door.

- i** Ensure that the centre seat belt is stowed correctly in its housing in the headlining.

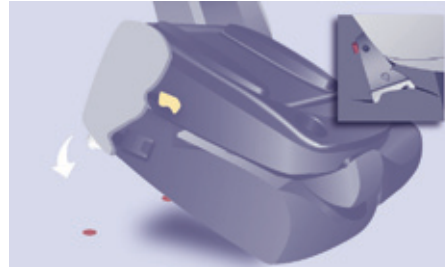

Operating the Row 2 seats

Removing a seat

- If necessary, move the front seats forward.
- Lower the head restraint.
- Place the seat in the fully folded position.
- Tilt the entire seat forwards then lift it.

Refitting the seat

The label on the seat indicates the position in which it must be installed.

- Place the hooks of the front feet between the two bars.
- Fold back the seat to fix the rear anchoring points.
- Operate the control to raise the seat back to its initial position.
- Raise the head restraint.



Ensure that no object or foot of a passenger seated in the rear is obstructing the anchorage points or preventing correct locking of the seat.



Operating the Row 3 seats

Removing the seat

- Lower the head restraint.
- Place the seat in the fully folded position.
- Tilt the entire seat forwards.
- On each side, take hold of the uprights of the folded seat, tilting it forward slightly, and lift it.

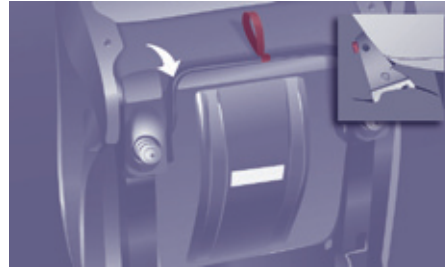

Refitting the seat

The label on the seat indicates the position in which it must be installed.

- Place the hooks of the front feet between the two bars.
- Ensure that no object or foot is obstructing the rear anchorage points and that the seat belt is positioned correctly and available for use.
- Fold back the seat to fix its rear anchoring feet.
- Operate the control to raise the seat back to its initial position.
- Raise the head restraint.

Good practice

Do not place hard or heavy objects on the seat backs forming a table, they could become dangerous projectiles in the event of sharp braking or impact.

Following the various operations:

- do not remove a head restraint without stowing it; secure it inside the vehicle,
- ensure that the passengers can always access the seat belts and fasten them easily,
- passengers must never take their seat without adjusting and fastening their seat belt.
- a passenger seated in row 3 must ensure that he does not obstruct the row 2 seat anchorage points,
- a passenger seated in row 3 must not have the seat in front of them in row 2 in the folded position; this is in case the seat could tip towards the passenger unexpectedly and injure them.

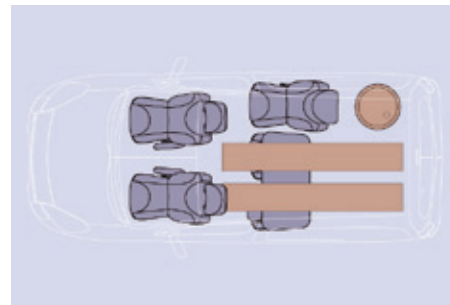
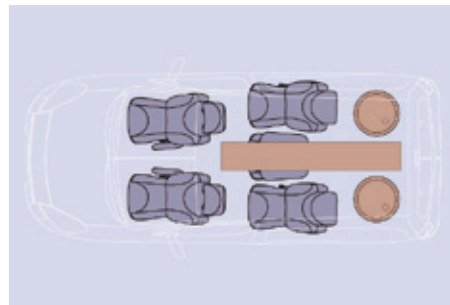
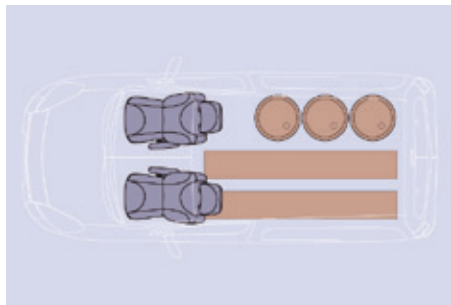
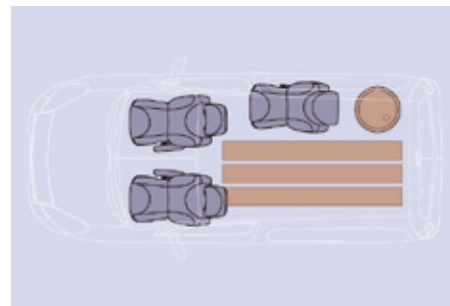
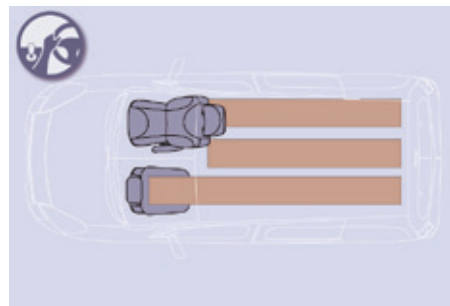
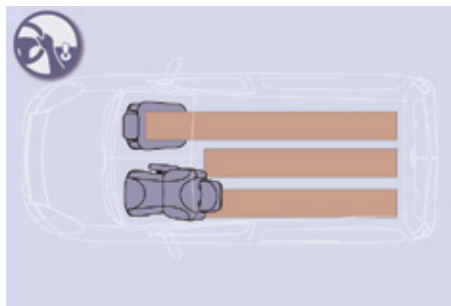

MODULARITY AND DIFFERENT SEAT CONFIGURATIONS

5 seat layouts

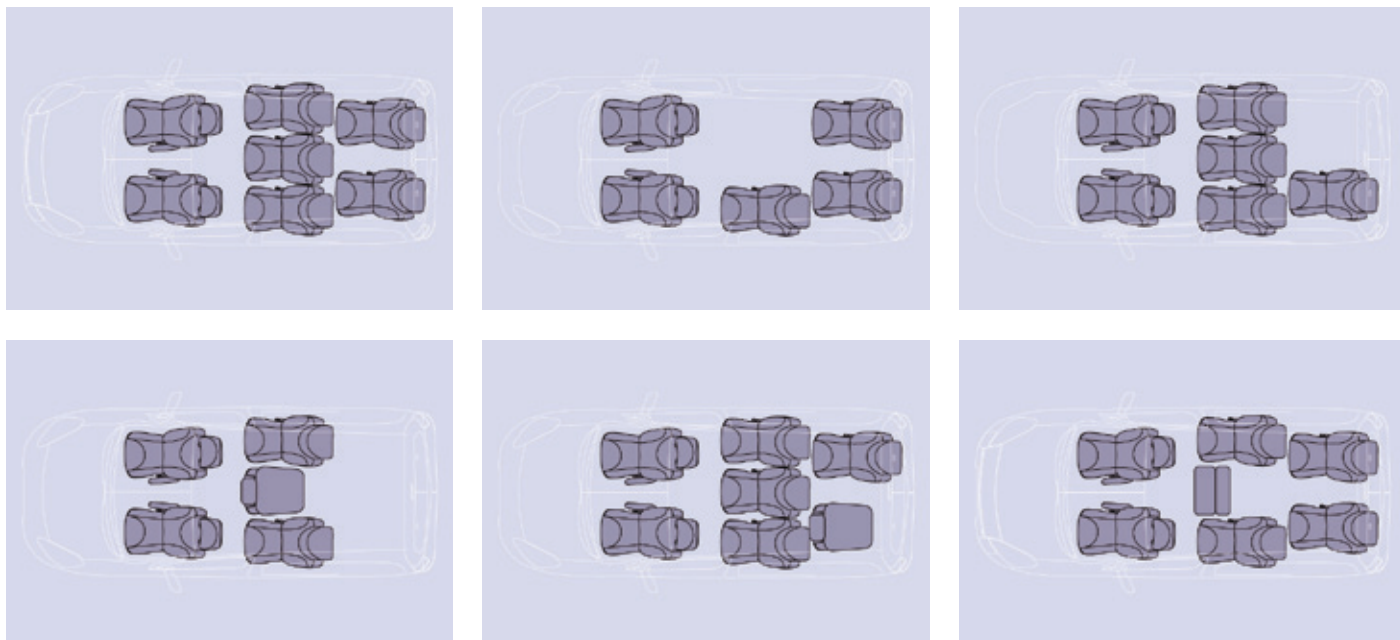

7 seat layouts



The various operations must be carried out while stationary.

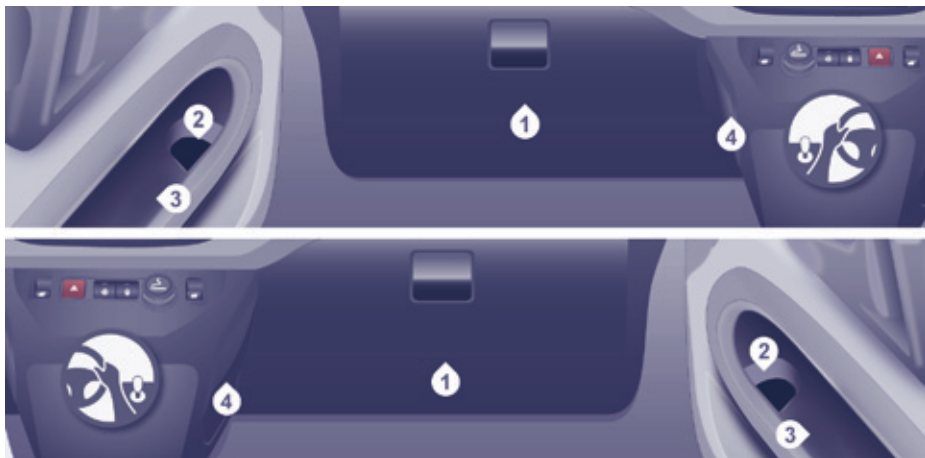
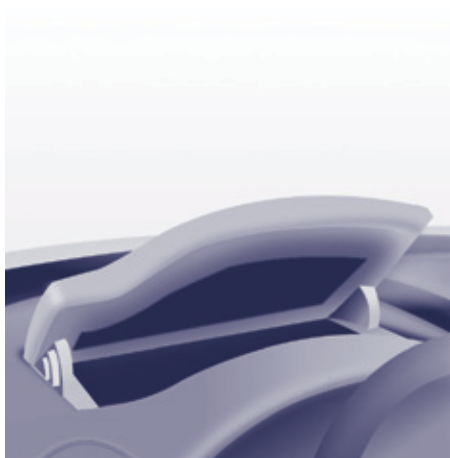

FRONT FITTINGS

Upper storage compartment

This is located on the dashboard, behind the steering wheel.

A recess makes lifting of the lid easier when opening. Guide it to its rest position.

To close, guide the lid then press the centre gently.

Any liquid which could spill risks causing an electrical short circuit and therefore a potential fire.

1. Lower glove box

This may or may not be fitted with a lid.

2. Storage pocket and bottle holder (1.5 L)

3. Side storage compartment

4. Bag hook

Only hang flexible bags which are not too heavy on this hook.

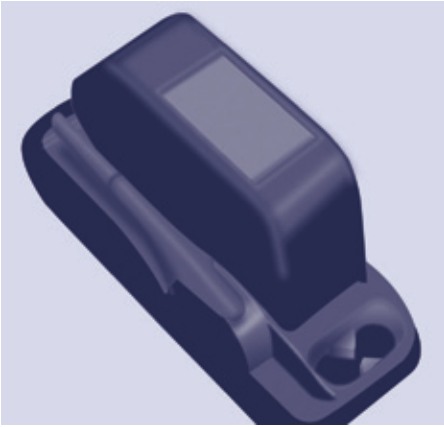

Central storage console

This console offers an appreciable additional storage area: it can be removed and clips onto a base which also incorporates two cup holders at the rear.

Ensure that the object (bottle, can...) placed in the cup holder is retained securely and does not risk being dislodged while driving.

Any liquid which could spill presents a risk of damage on contact with the instrument panel and centre console controls.

Take care.



Overhead storage unit

This is located above the sun visors and can accommodate various objects (a jumper, file, gloves...).

The openings concealed by the sun visors allow you to see and access the objects stored in the overhead storage unit.

The maximum weight permitted in the overhead storage unit is 5 Kg.

Do not place objects in this storage unit which could present a risk to the occupants.

Sun visor

To prevent dazzle from ahead, fold the sun visor down.

A pocket is provided in the driver's sun visor for storing toll cards, tickets, ...

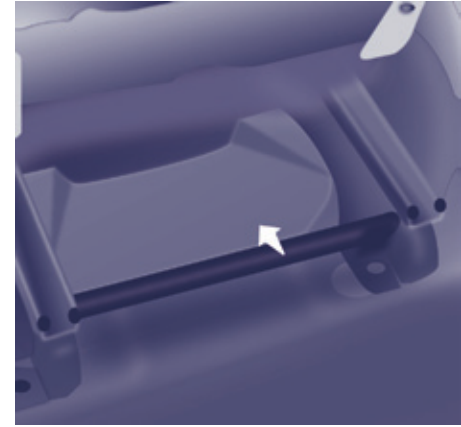

Storage compartment under seats

Storage compartments are available, with or without lid, in the floor under the front seats.

To gain access to them, move the seat forward. The lid must be lifted from the rear of the seat.

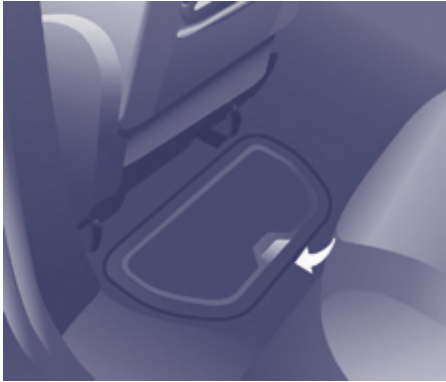

SEATING AREA FITTINGS

Floor boxes

Two boxes are available, located under the rear passenger footwells.

To open them, slide your fingers into the recess and lift the lid.



Aircraft style tables

To put the table in place, pull it upwards and fold it down.

As a safety precaution, above a high pressure, the table is designed to unhook.

To put it back in place, with the table vertical, engage one side then the other, forcing slightly.

Do not place hard or heavy objects on the table. They could become dangerous projectiles in the event of sharp braking or impact.

A bag hook is provided on the side of each table.

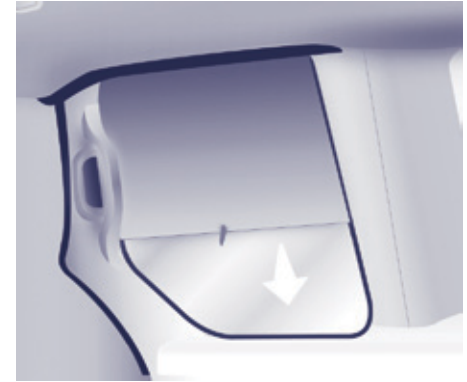

Side blinds

Side blinds may be available on the sliding side doors.

Pull the side blind by the tab to install it.

To avoid damaging the blind when opening the door, check that the tab is hooked securely.

 Always guide the blind slowly using the tab, both when raising and when lowering.

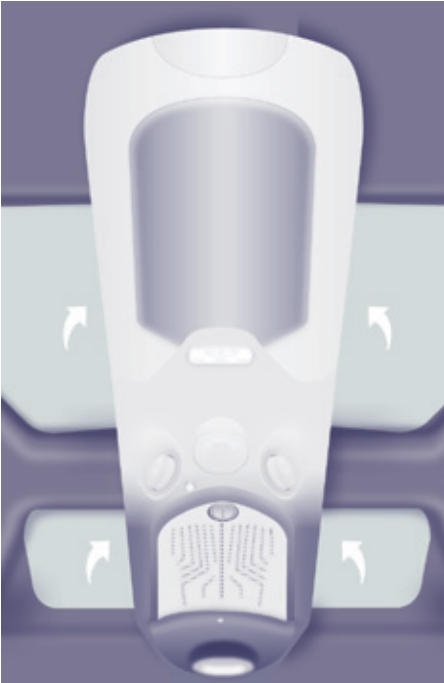

ZENITH ROOF

The multifunction roof extends the overhead storage unit. It consists of the following components:



Storage compartments

Storage compartments are provided on each side of the roof. The maximum authorised load is 6 kg.

The translucent base assists with finding objects stored inside.

Do not store objects which could present a risk to the occupants.



Courtesy lamp

The operation of the courtesy lamp is identical to that of the front courtesy lamp.

+ Refer to chapter 4 "Practical information", "Courtesy lamps" section.



From inside

Rear box

This roof box can be accessed from the rear seats and the boot. From the rear seats, slide the flaps to open.



From outside

From the boot, place your thumb on the recess then pull the handle to open.

 Open carefully to prevent objects stored in this interior roof box from falling out.

The maximum authorised load is 10 kg.



Vents

A 3-position control allows you to adjust the air flow through the vents. The vents are also fitted with a scented air freshener.



SCENTED AIR FRESHENER

The scented air freshener diffuses a fragrance in the passenger compartment from the roof console vents.

Adjusting the flow

Turn the chromed button to adjust the diffusion:

- to the left to decrease,
- to the right to increase.

To stop the diffusion, turn the chromed button fully to the left.



Removing the scented air freshener

- Press the button down while turning it a quarter of a turn to the left to the stop.
- Remove the scented air freshener from the roof console.
- Replace the cartridge.

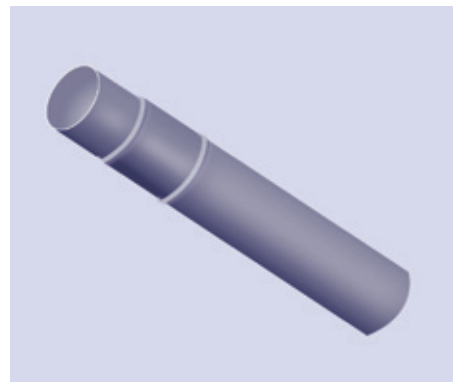
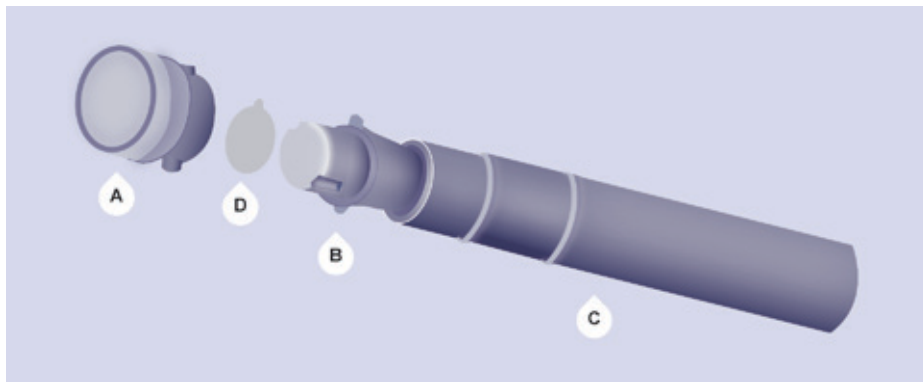

Replacing a cartridge

The scented air freshener refill consists of a cartridge **B** and its sealing case **C**.

- Remove the protective film **D**.
- Place the head of the cartridge **B** on the button **A** of the scented air freshener.
- Turn it a quarter of a turn to lock it on the button and remove the case.
- Insert the scented air freshener in its location.

You can change the cartridges at any time and store cartridges which have already been started in their original case.

The scented air freshener button **A** is independent of the cartridge.

The cartridges are supplied without the button **A**.

The scented air freshener button **A** can only be fixed on the multifunction roof console with a cartridge.

Therefore, always retain button **A** and a cartridge.

The cartridges are available from PEUGEOT dealers.

Inserting the scented air freshener

After fitting or changing the cartridge:

- Put the scented air freshener back in place in its location.
- Turn it a quarter of a turn to the right.

Good practice

As a safety precaution, only use the cartridges provided for this purpose. Do not dismantle the cartridges.

Keep the cartridge sealing cases which are used as packaging when the cartridges are not in use.

Never try to refill the cartridges with fragrances other than those available from PEUGEOT dealers.

Keep out of reach of children and animals. Avoid contact with the skin and eyes. If swallowed, consult a doctor and show him the packaging or product label.

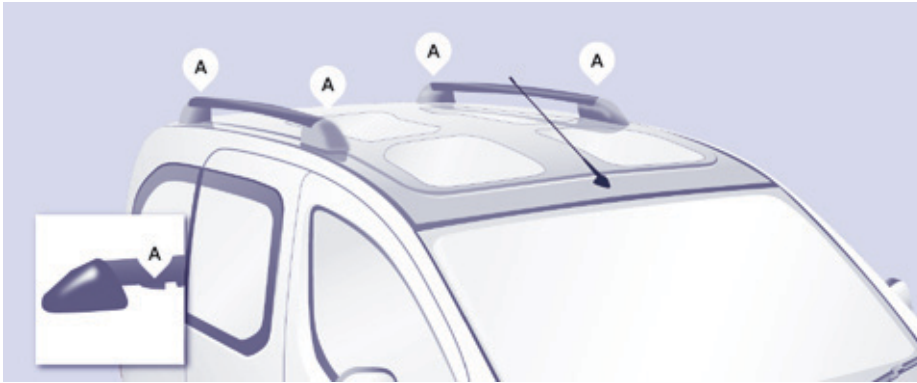

ZENITH ROOF BARS

These two longitudinal Zenith roof bars can be removed.

The maximum authorised weight on each roof bar is 35 kg.

Recommendations for loading the roof

This procedure requires the use of a spanner supplied with the tools for changing a wheel.

 Chapter 9, "Changing a wheel" section.

- Open the protective covers.
- Slacken the four screws using the spanner and remove them.
- Turn the bars 90° placing the hollow parts towards the front.
- Refit the the 4 screws and tighten them using the spanner.
- Close the protective covers.
- Use the strap passages **A** only to secure the load firmly.



In all cases, the load must rest on the non-slip bands provided for this purpose and must not touch the roof or the glazing of the roof.

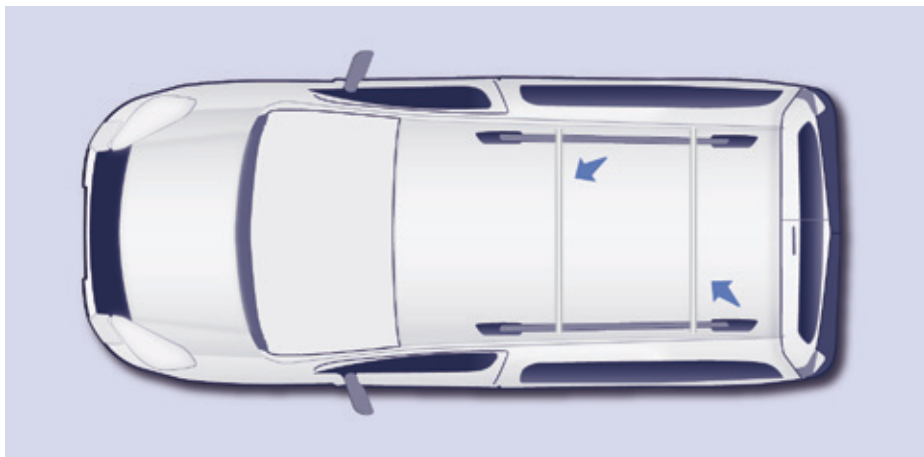

EXTERIOR ROOF BARS

If you install transverse bars on these bars, refer to the weight values indicated by the manufacturer but do not exceed: 75 kg.



Front courtesy lamp



Rear courtesy lamp



Front individual reading lamps

COURTESY LAMPS

Automatic switching on/off

The front courtesy lamp comes on when the key is removed from the ignition, when the vehicle is unlocked, when one of the front doors is opened and for location of the vehicle using the remote control.

It goes off gradually after the ignition is switched on and when the vehicle is locked.



Permanently on, ignition on.



Front seats: comes on when one of the front doors is opened.



Rear seats: comes on when one of the rear doors is opened.

If the doors remain open for a few minutes, the courtesy lamps go off.



Permanently off.



These are switched on and off by means of a manual switch, with the ignition on.

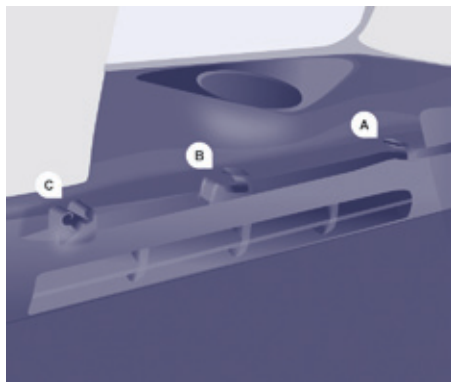

LOAD SPACE COVER (5 SEAT VERSION)

This rigid shelf conceals the objects stored in the boot.

Folding

From the boot, fold the half-shelf, raising it to detach it from the notch **C**.

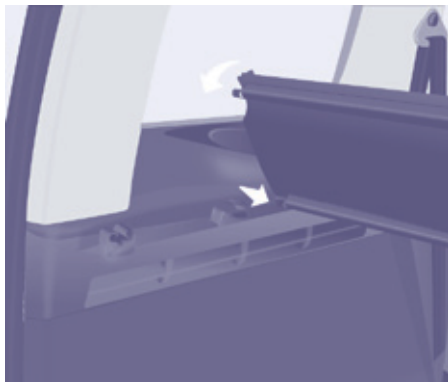

Removing

Fold the load space cover.
Detach it from the notches **A** and **B** pulling it towards you.
Raise it and remove the assembly.

Refitting

Place the load space cover in front of **A** and **B**.
Push it forwards to insert the lugs in the notches.
Unfold and clip into the notches **C**.



Storing (according to version)

A location is provided in the back of the rear seats to accommodate the load space cover folded onto itself.
Slide it vertically between the side guides located at mid seat back height.
Insert the hinge first, with the free flaps turned upwards.

 This rigid load space cover can form a shelf. However, as a safety measure, do not place objects on it which could become dangerous projectiles in the event of sharp braking or rear impact.



12 volt socket (120 W max)

It is advisable to limit the use of this socket to avoid discharging the battery.

! The connection of an electrical device not approved by PEUGEOT, such as a USB charger, may adversely affect the operation of vehicle electrical systems, causing faults such as poor telephone reception or interference with displays in the screens.

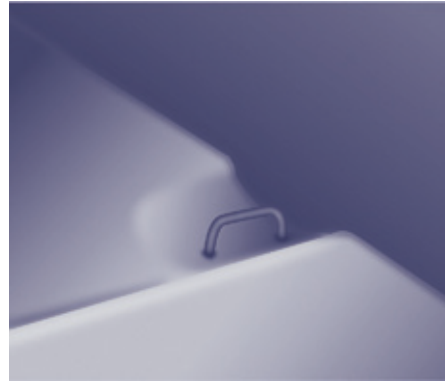

Stowing rings

Use these rings to secure loads on the floor.



Protective net

Open the cover located in the hook support.
 Fix the top of the net in the notches, having first turned the bar 1/4 of a turn.
 Ensure that the end of the bar engages correctly in the metal part of its location.
 Fix the straps in the locations provided on the floor.
 Tighten the net using the straps.

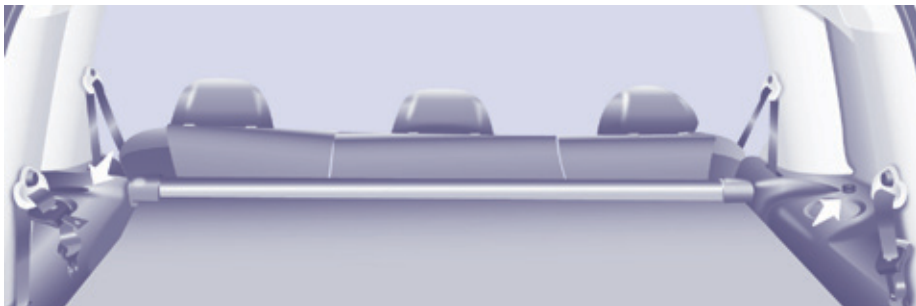

REAR FITTINGS (7 SEAT VERSION)

Cup holder

Any liquid carried in a cup (mug or other) on board which could spill, presents a risk.
Take care.

12 volt socket (120 W max)

It is advisable to limit the use of this socket to avoid discharging the battery.



Stowing rings

Use the stowing rings on the floor to secure and retain your loads firmly.
The seat belt anchorages must not be used for this purpose.

 It is recommended that the load is immobilised by securing it firmly using the stowing rings on the floor.



Seat belts

Ensure that the centre seat belt has reeled in correctly to its carrier in the roof.

Prevent the row 3 seat belt buckles from knocking by raising them as close as possible to the anchorages in the roof.

The seat belt buckle attachment rings on each side of the boot must not be used to retain loads.

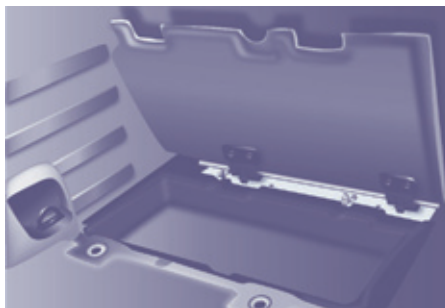

Storage flaps

Raise the corresponding flap.

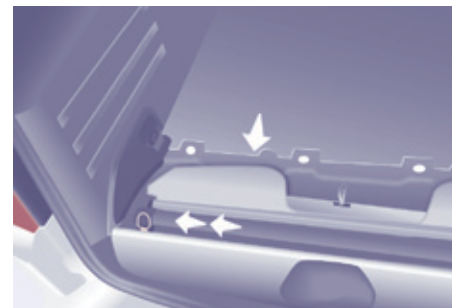

Next to the boot sill, the recess is intended to receive the roller tube containing the load space cover.

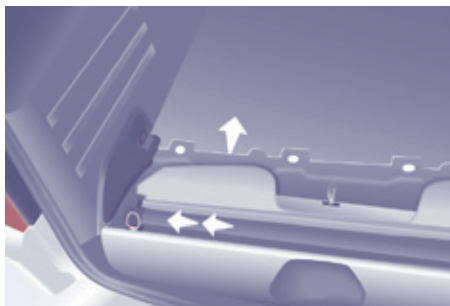

BLIND, LOAD SPACE COVER

The load space cover is the roller blind type. Take care not to place heavy objects on the load space cover when unreeled.

To install it

Place the row 3 seats in the fully folded position.

Raise the storage flap at the boot sill.

Take hold of the roller in the centre and compress it towards the left-hand pillar.

Raise the assembly.

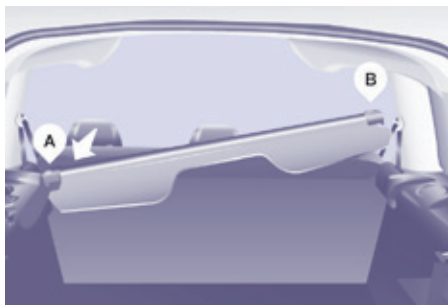
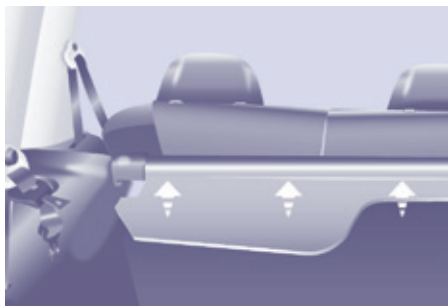

Position the load space screen so as to present the rear load space cover flaps towards you.

Engage the left-hand lug of the roller in the support **A**.

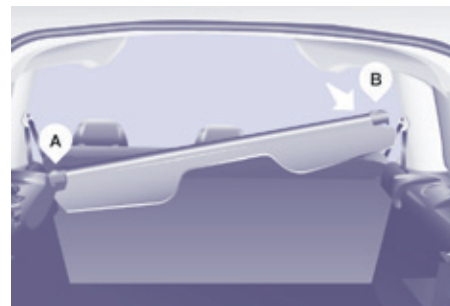

Compress then place the right-hand lug facing the support **B**.

Release to engage the roller in its support.

Unroll the load space cover to the rear side pillars.

Engage the ends in the rear notches to keep it taut.

i The roller is fitted with three flaps permitting concealment of the boot, whether the row 2 seats are in the normal position or the comfort position.

Each flap has two clips which are hooked on the base of each head restraint.

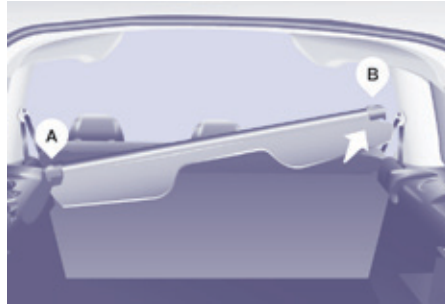
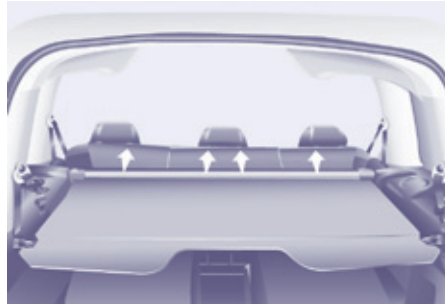

To remove it

From the boot, pull the load space cover towards you to release it from the side pillars.

Guide the load space cover as it rolls up.

Remove the clips of the three flaps from the base of each row 2 head restraint. Compress the roller to the left to remove it from the support **B**.

Raise it and pivot it forwards.

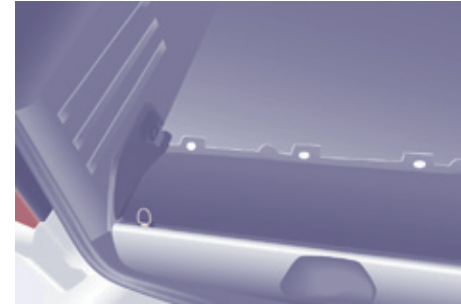
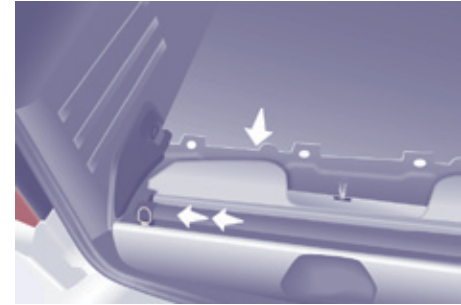

To store it

Store it in the recess at the boot sill, with the two rear flaps uppermost.

First, compress the load space screen to the left.

Release.

Arrange the two flaps and close the storage flap.



MIRRORS

Adjusting manual door mirrors

Move the lever in all four directions to adjust.

When the vehicle is parked, the door mirrors can be folded back manually. The mirrors are not equipped with automatic heating.



Adjusting electric door mirrors

- Move the control to the right or to the left to select the corresponding mirror.
- Move the control in all four directions to adjust.
- Return the control to the central position.

Electric folding / unfolding

The mirrors can be folded or unfolded electrically from the inside, with the vehicle parked and the ignition on:

- Place the control in the central position.
- Turn the control downwards.



Heated mirrors

The mirrors that have electric folding/unfolding can be heated.



Press the heated rear screen button.

Forced folding

If the mirror casing has come out of its initial location, with the vehicle stationary reposition the mirror casing manually or use the electric folding control.



Manual rear view mirror

The rear view mirror has two positions:

- day (normal),
- night (anti-dazzle).

To change from one to the other, push or pull the lever on the lower edge of the mirror.



SURVEILLANCE MIRROR

This mirror, placed on top of the central mirror, enables the driver or front passenger to observe all the rear seats.

Fitted on its own ball joint, its manual adjustment is simple and provides a view of the rear interior of the vehicle. It can also be adjusted for improved visibility during manoeuvres or when overtaking.



REAR WINDOWS

To partially open the rear windows, tilt the lever and push it fully to lock the windows in the open position.



ELECTRIC WINDOWS

1. Driver's side
2. Passenger's side

There are two operating modes:

Manual mode

Press or pull the control, without passing the point of resistance.

The window stops when you release the control.

One-touch mode

Press or pull the control, beyond the point of resistance.

The window opens or closes fully when the control is released.

Pressing or pulling the control again stops the movement of the window.



This mode is available depending on equipment; it is identified by this symbol on the control in question.

The electrical functions of the electric windows are deactivated:

- approximately 45 seconds after the ignition is switched off,
- after one of the front doors is opened, if the ignition is off.

Safety anti-pinch

When the window rises and meets an obstacle, it stops and partially lowers.

Reinitialisation

Following reconnection of the battery, or in the event of a malfunction, the safety anti-pinch function must be reinitialised.

Lower the window fully, then raise it, it will rise in steps of a few centimetres each time the control is pressed. Repeat the operation until the window is fully closed.

Continue to press the control for at least one second after the window closed position has been reached.

The safety anti-pinch does not operate during these operations.

Good practice

If the electric windows meet an obstacle during operation, you must reverse the movement of the window. To do this, press the control concerned.

When the driver operates the passenger electric window controls, they must ensure that no one is preventing correct closing of the windows.

The driver must ensure that the passengers use the electric windows correctly.

Be aware of children when operating the windows.

Following several consecutive closing/opening operations of the electric window control, a protection system is triggered which only allows closing of the window. After closing, wait approximately 40 minutes. Once this time has elapsed, the control becomes operational again.

GENERAL SAFETY RECOMMENDATIONS

! Labels are applied at various points on your vehicle. They carry safety warnings as well as vehicle identification information. Do not remove them: they form an integral part of your vehicle.

! For any work on your vehicle, use a qualified workshop that has the technical information, skills and equipment required, all of which a PEUGEOT dealer is able to provide.

! **We draw your attention to the following points:**

- The fitting of electrical equipment or accessories not listed by PEUGEOT may cause excessive current consumption and faults and failures with the electrical system of your vehicle. Contact a PEUGEOT dealer for information on the range of recommended accessories.
- As a safety measure, access to the diagnostic socket, used for the vehicle's electronic systems, is reserved strictly for PEUGEOT dealers or qualified workshops, equipped with the special tools required (risk of malfunctions of the vehicle's electronic systems that could cause breakdowns or serious accidents). The manufacturer cannot be held responsible if this advice is not followed.
- Any modification or adaptation not intended or authorised by Automobiles PEUGEOT or carried out without meeting the technical requirements defined by the manufacturer would lead to the suspension of the legal and contractual warranties.

! **Installation of accessory radio communication transmitters**

Before installing a radio communication transmitter, you must contact a PEUGEOT dealer for the specification of transmitters which can be fitted (frequency, maximum power, aerial position, specific installation requirements), in line with the Vehicle Electromagnetic Compatibility Directive (2004/104/EC).

! Depending on the legislation in force in the country, certain safety equipment may be compulsory: high visibility safety vests, warning triangles, breathalysers, spare bulbs, spare fuses, fire extinguisher, first aid kit, mud flaps at the rear of the vehicle...

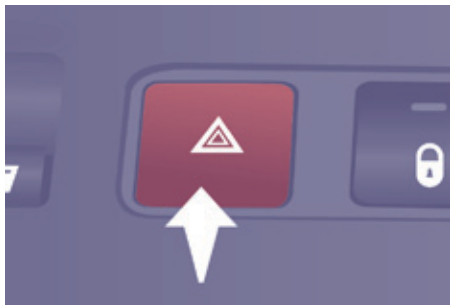

HAZARD WARNING LAMPS

Press this button, the direction indicators flash.

They can operate with the ignition off.

The hazard warning lamps should only be used in dangerous situations, when stopping in an emergency or when driving in unusual conditions.

Automatic operation of hazard warning lamps

When braking in an emergency, depending on the force of deceleration, the hazard warning lamps come on automatically. They switch off automatically the first time you accelerate.

It is also possible to switch them off by pressing the switch on the dashboard.

HORN

Press the centre of the steering wheel.



PARKING BRAKE

Applying

Pull the parking brake lever up to immobilise your vehicle.

Check that the parking brake is applied firmly before leaving the vehicle.



If the parking brake is still on or has not been released properly, this is indicated by this warning lamp which comes on in the instrument panel.

When parking on a slope, direct your wheels towards the pavement and pull the parking brake lever up.

There is no advantage in engaging a gear after parking the vehicle, particularly if the vehicle is loaded.

Pull on the parking brake lever, **only with the vehicle stationary.**

In the exceptional case of use of the parking brake when the vehicle is moving, apply the brake by pulling gently to avoid locking the rear wheels (risk of skidding).

Releasing

Pull the lever up slightly and press the button to lower the parking brake lever.



PARKING SENSORS

The audible (front and rear) and visual (rear) parking sensor system consists of proximity sensors, installed in the rear bumper.

The sensors detect any obstacle which enters its field of operation: person, vehicle, tree, fence, behind the vehicle during the manoeuvre.

Certain objects detected at the beginning of the manoeuvre will no longer be detected at the end of the manoeuvre due to the blind spots between and below the sensors.

Examples: stake, roadworks cone or pavement post.

Engage reverse gear

An audible signal confirms the activation of the system by engaging reverse gear.

The proximity information is indicated by an audible signal which becomes more rapid as the vehicle approaches the obstacle.

When the distance between the rear of the vehicle and the obstacle is less than approximately thirty centimetres, the audible signal becomes continuous.

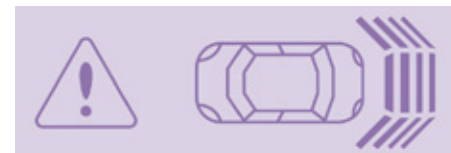

Display in the screen

Parking sensors



Engage forward gear

In addition to the rear parking sensors, the front parking sensors are triggered when an obstacle is detected in front of the vehicle and the speed of the vehicle remains below 6 mph (10 km/h).

i The tone from the speaker (front or rear) allows an obstacle to be identified as either in front of or behind the vehicle.

Stop the assistance

Change to neutral.



Activation / Deactivation



You can activate or deactivate the system by pressing this button.

The activation or deactivation of the system is stored when the vehicle stops.

Malfunction

In the event of a malfunction, the LED in the button comes on, accompanied by an audible signal and a message in the screen.

Contact a PEUGEOT dealer or qualified workshop.

Good practice

In bad weather or in winter, ensure that the sensors are not covered with mud, ice or snow.

The system will be deactivated automatically if a trailer is being towed or if a bicycle carrier is fitted (vehicle fitted with a towbar or bicycle carrier recommended by PEUGEOT).

! The parking sensor system cannot, in any circumstances, take the place of the vigilance and responsibility of the driver.



REVERSING CAMERA

The reversing camera is activated automatically when reverse gear is engaged.

The image is displayed in the touch screen.

The reversing camera function may be completed with parking sensors.

i The reversing camera cannot in any circumstances be a substitute for vigilance on the part of the driver.

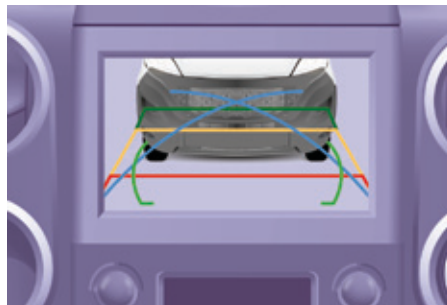

i High pressure jet washing

When washing your vehicle, do not direct the lance within 30 cm of the camera lens.

The superimposed representation of guide lines helps with the manoeuvre. They are represented by lines marked "on the ground" and do not allow the position of the vehicle to be determined relative to tall obstacles (for example: other vehicles, ...).

Some deformation of the image is normal.

The blue lines represent the general direction of the vehicle (the difference corresponds to the width of your vehicle without the mirrors).

The red lines represent a distance of about 30 cm beyond the edge of your vehicle's rear bumper.

The green lines represent distances of about 1 and 2 metres beyond the edge of your vehicle's rear bumper.

The turquoise blue curves represent the maximum turning circle.

i Opening the tailgate causes the display to disappear.

Clean the reversing camera regularly using a soft, dry cloth.

Driving safely

ANTI-LOCK BRAKING SYSTEM (ABS / EBFD)

The ABS and EBFD (electronic brake force distribution) systems improve the stability and manoeuvrability of your vehicle on braking, in particular on poor or slippery surfaces.

The ABS prevents locking of the wheels, the EBFD provides control of the braking pressure wheel by wheel.

Good practice

The anti-lock braking system comes into operation automatically when there is a risk of wheel lock. It does not reduce the braking distance.

On very slippery surfaces (ice, oil, etc...) the ABS may increase the braking distance. When braking in an emergency, do not hesitate to press the brake pedal firmly, without releasing the pressure, even on a slippery surface, you will then be able to continue to manoeuvre the vehicle to avoid an obstacle.

Normal operation of the ABS may be felt by slight vibration of the brake pedal.

When changing wheels (tyres and rims), ensure that these are listed by PEUGEOT for the vehicle.



If this warning lamp comes on, accompanied by an audible signal and a message in the screen, it indicates a malfunction of the ABS which could result in a loss of control of the vehicle on braking.



If this warning lamp comes on, together with the brake and STOP warning lamps, accompanied by an audible signal and a message in the screen, it indicates a malfunction of the electronic brake force distribution which could result in a loss of control of the vehicle on braking.

Stop as soon as it is safe to do so.

In both cases, contact a PEUGEOT dealer or a qualified workshop.

EMERGENCY BRAKING ASSISTANCE (EBA)

In an emergency, this system enables the optimum braking pressure to be reached more quickly, press the pedal firmly without releasing it.

It is triggered by the speed at which the brake pedal is pressed down.

This alters the resistance of the brake pedal under your foot.

To maintain operation of the emergency braking assistance system: keep your foot on the brake pedal.



ANTI-SLIP REGULATION (ASR) AND DYNAMIC STABILITY CONTROL (DSC)

These systems are linked and complement the ABS.

The ASR system is very useful for maintaining optimum drive and avoiding losses of control of the vehicle on acceleration.

The system optimises drive to prevent the wheels skidding, by acting on the brakes of the drive wheels and on the engine. It also allows the directional stability of the vehicle to be improved on acceleration.

Use the DSC to hold your course without attempting to countersteer.

If there is a variation between the trajectory followed by the vehicle and that required by the driver, the DSC system automatically acts on the engine and the brake of one or more wheels, in order to put the vehicle back on course.

Operation



The warning lamp flashes when operation of the ASR or DSC is triggered.

Deactivation

In certain exceptional conditions (starting the vehicle when stuck in mud or snow, or on loose ground...), it could prove useful to deactivate the ASR and DSC systems to make the wheels spin and regain grip.



- Press the button or turn the dial to the DSC OFF position (depending on model).
- The LED comes on: the ASR and DSC systems no longer come into play.

They engage again:



- automatically above 30 mph (50 km/h),
- manually by pressing the button again or by turning the dial to this position (depending on model).

Operating fault



When a malfunction of the systems occurs, the warning lamp and the LED come on, accompanied by an audible signal and a message in the screen.

Contact a PEUGEOT dealer or a qualified workshop to have the system checked.

The warning lamp may also come on if the tyres are under-inflated. Check the pressure of each tyre.

Good practice

The ASR/DSC systems offer increased safety during normal driving, but should not incite the driver to take risks or to drive at high speed.

The operation of these systems is ensured if the recommendations of the manufacturer regarding the wheels (tyres and rims), the braking components, the electronic components and the fitting and repair procedures are observed.

After an impact, have these systems checked by a PEUGEOT dealer or a qualified workshop.



GRIP CONTROL

On snow, mud or sand, traction control is obtained by a compromise between safety, grip, traction and appropriate tyres.

It adapts to allows most conditions of poor grip to be accommodated.

The accelerator pedal must be pressed enough for there to be adequate engine power to manage the various parameters in the best way.

Correct use

Your vehicle is designed principally to drive on tarmac roads but it allows you to drive on other less passable terrain occasionally.

However, particularly when your vehicle is heavily laden, it does not permit off-road activities such as:

- crossing and driving on ground which could damage the underbody or tear off components (fuel pipe, fuel cooler, ...), particularly by obstacles or stones,
- driving on ground with steep gradients and poor grip,
- crossing a stream.

Different **modes** are available:

Normal (ESC)



This mode is calibrated for a low level of skidding, based on different conditions of grip encountered on the road.

When the ignition is switched off, the system returns automatically to DSC mode.

ESC OFF



This mode is only suitable for specific conditions encountered when moving off or at low speed.

Above 30 mph (50 km/h) the system returns to DSC mode automatically.

Snow



This mode allows the vehicle to adapt its strategy to the conditions of grip encountered for each of the two front wheels, on moving off.

When moving, the system optimises wheelspin to provide the best acceleration possible for the grip available.

Off road (mud, wet grass, ...)



When moving off, this mode allows considerable wheelspin on the wheel with the least grip to favour clearing of the mud and regain "grip".

At the same time, the wheel with the most grip is controlled in such a way as to transmit as much torque as possible.

When moving, the system optimises wheelspin to meet the driver's requirements as fully as possible.

Sand



This mode allows a little wheelspin on the two driving wheels at the same time to allow the vehicle to move forward and reduces the risk of getting stuck in the sand.

Do not use the other modes on sand as the vehicle may become stuck.

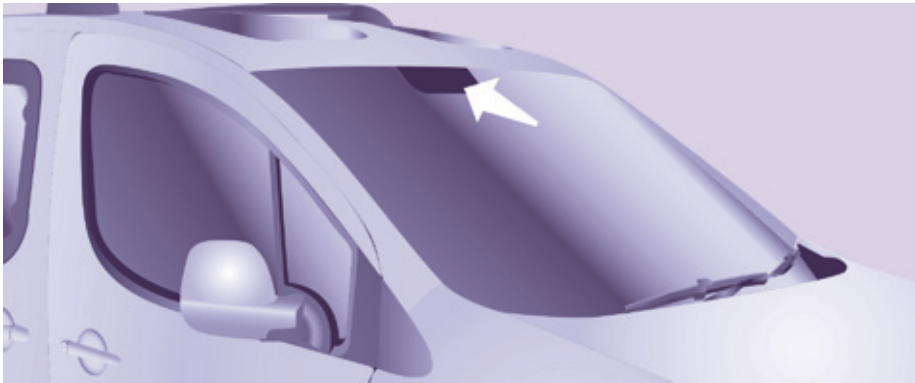

ACTIVE CITY BRAKE

Active City Brake is a driving assistance system that aims to avoid a frontal collision or reduce the speed of an impact if the driver does not react sufficiently (inadequate brake application).

! This system is designed to improve driving safety.

It remains the driver's responsibility to continuously monitor the state of the traffic and to assess the distances and relative speeds of other vehicles.

Active City Brake can in no circumstances replace the need for vigilance on the part of the driver.

Principle

Using a laser sensor located at the top of the windscreen, this system detects a vehicle running in the same direction or stationary ahead of your vehicle.

When necessary, the vehicle's braking system is operated automatically to avoid a collision with the vehicle ahead.

! Automatic braking occurs later than if done by the driver, so as to intervene only when there is a high risk of collision.

Conditions for activation

Active City Brake only operates if the following conditions are met:

- ignition on,
- the vehicle is in a forward gear,
- speed is between about 3 and 18 mph (5 and 30 km/h),
- the braking assistance systems (ABS, EBFD, emergency braking assistance) are not faulty,
- the trajectory control systems (ASR, DSC) are not deactivated or faulty,
- the vehicle is not in a tight corner,
- the system has not been triggered during the previous 10 seconds.

! Never look at the laser sensor through an optical instrument (magnifying glass, microscope...) at a distance of less than 10 centimetres: risk of eye injury.

Operation

When your vehicle is too close to or approaches the vehicle ahead too quickly the system automatically applies the brakes to avoid a collision. You are then alerted by the display of a message.

The brake lamps on your vehicle come on to warn other road users.

The collision can be avoided automatically if the difference in speed between your vehicle and the vehicle ahead does not exceed 9 mph (15 km/h).

Above this threshold, the system will do what is possible to avoid or reduce the accident by lowering the speed of impact.

The automatic braking may bring the vehicle to a complete stop if the situation requires it.

In this case, the vehicle is held stationary temporarily (for about 1.5 seconds) to allow the driver to take back control by pressing the brake pedal.

i The triggering of the system may cause the engine to stall, unless the driver depresses the clutch pedal quickly enough during automatic braking.

i During automatic braking, the driver can always obtain a higher rate of deceleration than that controlled by the system, by pressing firmly on the brake pedal.

i After an impact, the system is automatically put out of service: it no longer operates.

You must go to a PEUGEOT dealer or a qualified workshop to have the system made operational again.

Operating limits

The system only detects vehicles that are stationary or moving in the same direction as your vehicle.

i It does not detect small vehicles (bicycles, motorcycles), pedestrians or animals, nor non-reflective stationary objects.

The system is not triggered or is interrupted if the driver:

- accelerates strongly
- or turns the steering wheel suddenly (avoiding manoeuvre).

i In difficult weather conditions (very heavy rain, snow, fog, hail...), braking distances increase, which can reduce the ability of the system to avoid a collision.

The driver must therefore remain particularly vigilant.

i Never leave accumulations of snow or any object projecting above the bonnet or in front of the roof: this might fall into the field of vision of the sensor and generate a detection.

Deactivation

The system is deactivated in the vehicle configuration menu, accessible with the ignition on.

Its state is memorised when the ignition is switched off.

i When the system is deactivated, a message is displayed every time the ignition is switched on, to warn you.

With the monochrome screen C

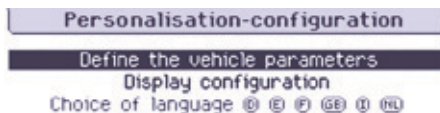

- ☞ Press the **MENU** button for access to the main menu.
- ☞ Select "**Personalisation-Configuration**".
- ☞ Select "**Define vehicle parameters**".
- ☞ Select "**Driving assistance**".
- ☞ Select "**Automatic emergency braking: OFF**" or "**Automatic emergency braking: ON**".
- ☞ Press the "◀" or "▶" button to check or uncheck the box and activate or deactivate the system respectively.
- ☞ Press the "▲" or "▼" button, then the **OK** button to select the "**OK**" box and confirm or the **Back** button to cancel.

With the touch screen

- ☞ Press the "**MENU**" button.
- ☞ Select the "**Driving**" menu.
- ☞ In the secondary page, select "**Vehicle settings**".
- ☞ Select the "**Driving assistance**" tab.
- ☞ Check or uncheck the "**Auto emergency braking**" box to activate or deactivate the system.
- ☞ Confirm.

Operating faults

Sensor fault

The operation of the laser sensor may suffer interference from accumulations of dirt or misting of the windscreen. In this case you are warned by the display of a message.

Use the windscreen demisting and regularly clean the area of the windscreen in front of the sensor.

 Do not stick or otherwise fix any object on the windscreen in front of the sensor.

System fault

In the event of a malfunction of the system, you are warned by an audible signal and the display of the message "**Automatic braking system fault**".

Have the system checked by a PEUGEOT dealer or a qualified workshop.

 In the event of an impact to the windscreen at the sensor, deactivate the system and contact a PEUGEOT dealer or a qualified workshop to have your windscreen replaced.

 Never try to remove, adjust or test the sensor.
Only a PEUGEOT dealer or a qualified workshop is able to work on the system.

 When towing a trailer or when the vehicle is being towed, the system must be deactivated.

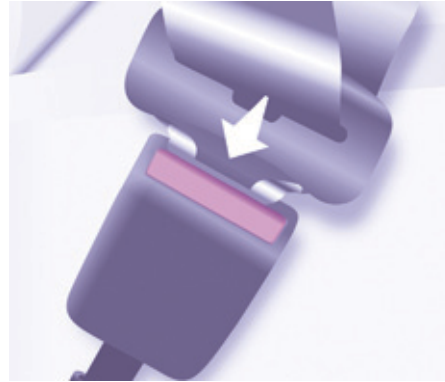

SEAT BELTS

Height adjustment

Squeeze the control with the return and slide the assembly on the driver's seat side and on the individual passenger seat side.

Fastening

Pull the strap, then insert the tongue into the buckle.

Check that the seat belt is fastened correctly by pulling the strap.

Unfastening

Press the red button.

Seat belt(s) not fastened warning lamp



When the vehicle is started, this warning lamp comes on if a user at the front has not fastened their seat belt.

The front passenger's seat may be fitted with a presence detector, in which case you should not place anything heavy on this seat as this could trigger the alert.

Good practice

The driver must ensure that passengers use the seat belts correctly and that they are all strapped in securely before moving off.

Wherever you are seated in the vehicle, always fasten your seat belt, even for short journeys.

The seat belts are fitted with an inertia reel which automatically adjusts the length of the strap to your size.

Do not use accessories (clothes pegs, clips, safety pins, etc.) which allow the seat belt straps to fit loosely.

Ensure that the seat belt has reeled in correctly after use.

After folding or moving a seat or a rear bench seat, ensure that the seat belt has reeled in correctly and that the buckle is ready to accommodate the tongue.

Depending on the nature and seriousness of any impact, the pretensioning device may be deployed before and independently of inflation of the airbags. It instantly tightens the seat belts against the body of the occupants.

Deployment of the pretensioners is accompanied by a slight discharge of harmless smoke and a noise, due to the activation of the pyrotechnic cartridge incorporated in the system.

The force limiter reduces the pressure of the seat belt against the body of the occupants.

The pretensioning seat belts are active when the ignition is switched on.

The inertia reels are fitted with a device which automatically locks the strap in the event of a collision or emergency braking or if the vehicle rolls over.

You can unfasten the seat belt by pressing the red button on the buckle. Guide the seat belt after unfastening.

The airbag warning lamp comes on if the pretensioners are deployed. Contact a PEUGEOT dealer or a qualified workshop.

In order to be effective, a seat belt:

- must restrain one person only,
- must not be twisted, check by pulling in front of you with an even movement,
- must be tightened as close to the body as possible.

The upper part of the seat belt should be positioned in the hollow of the shoulder.

The lap part should be placed as low as possible on the pelvis.

Do not interchange the seat belt buckles as they will not fulfil their role properly. If the seats are fitted with armrests, the lap part of the seat belt should always pass under the armrest.

Check that the seat belt is fastened correctly by pulling the strap firmly.

Recommendations for children:

- use a suitable child seat if the passenger is less than 12 years old or shorter than one metre fifty,
- never allow a child to travel on your lap, even with the seat belt fastened.

 For more information on child seats, refer to the "Child safety" section of chapter 5.

In accordance with current safety regulations, your PEUGEOT dealer can guarantee all work or any checks, from testing to maintenance, on your seat belt equipment.

Have the seat belts checked regularly (even after a minor impact) by a PEUGEOT dealer or a qualified workshop: they must not show any signs of wear, cutting or fraying and they must not be converted or modified.

 Clean the seat belt straps with soapy water or a textile cleaning product, sold by PEUGEOT dealers.

Front seat belts

The front seats are fitted with pretensioners and force limiters.

Rear seat belts (5 seat version)

The rear seats are fitted with three-point inertia reel seat belts.

Seat belts

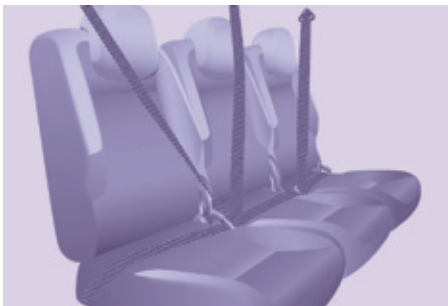

Rear seat belts (7 seat version)

In row 2

The three seats are fitted with three-point inertia reel seat belts. When folding the side seats or the seat backs to the table position, avoid trapping the strap of the centre seat belt.

When handling the side seats (removing/installing) or when accessing row 3, avoid hooking the centre seat belt.

Ensure that the centre seat belt is rolled up correctly in its strengthener on the roof.



In row 3

The two seats are fitted with three-point inertia reel seat belts.

Do not attach the seat belts to the stowing rings marked with a red cross, represented on the label.

Take care to hook the seat belts correctly on the rings provided for this purpose.



The row 3 seat belts which are not in use can be stored to clear the load space and make use of the load space cover easier.

Hook the snap hook in the location provided on the rear pillar trim.

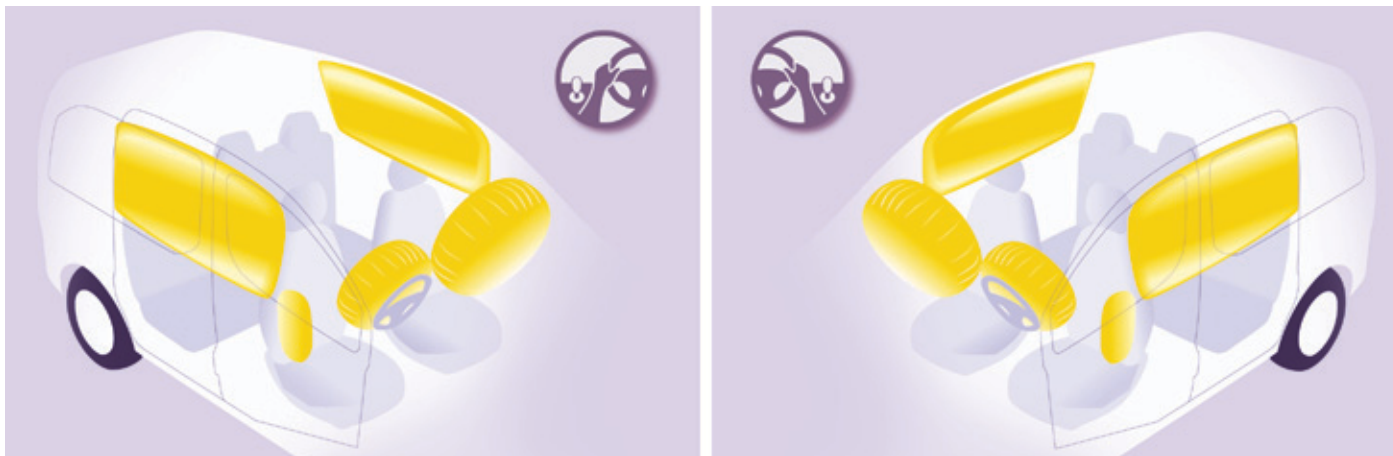

AIRBAGS

General information

The airbags have been designed to maximise the safety of the occupants in the event of a serious collision; they work in conjunction with the force limiting seat belts.

In the event of a serious collision, the electronic detectors record and analyse the front and side impacts suffered in the impact detection zones:

- in the event of a serious impact, the airbags inflate instantly and contribute towards better protecting the occupants of the vehicle; immediately after the impact, the airbags deflate rapidly, so that they do not hinder the visibility of the occupants nor their possible exit from the vehicle.

- in the event of a minor or rear impact and in certain roll-over conditions, the airbags will not be deployed; the seat belt alone is sufficient to contribute towards your protection in these situations.

The seriousness of the collision depends on the nature of the obstacle and the speed of the vehicle at the moment of impact.

i Airbags only operate when the ignition is switched on.

This equipment only operates once. If a second impact occurs (during the same or a subsequent accident), the airbag will not operate.

The deployment of an airbag or airbags is accompanied by a slight discharge of smoke and a noise, due to the activation of the pyrotechnic cartridge incorporated in the system.

This smoke is not harmful, but sensitive individuals may experience some irritation.

The noise of the detonation may result in a slight loss of hearing for a short time.



+ The passenger's front airbag must be deactivated if a child seat is installed rearward facing.

Chapter 5, "Child safety" section.

Advice

Sit in a normal upright position.

Wear a correctly adjusted seat belt.

Do not allow anything to come between the occupants and the airbags (a child, pet, object...), do not attach or fix anything near to the airbags or their trajectories when inflating as this could cause injuries when the airbags are deployed.

Never modify the original definition of your vehicle, particularly in the area directly around the airbags.

After an accident or if the vehicle has been stolen or broken into, have the airbag systems checked.

All work on the airbag system must be carried out by a PEUGEOT dealer or a qualified workshop.

Even if all of the precautions mentioned are observed, a risk of injury or of minor burns to the head, chest or arms when an airbag is deployed cannot be ruled out. The bag inflates almost instantly (within a few milliseconds) then deflates within the same time discharging the hot gas via openings provided for this purpose.

Front airbags

Do not drive holding the steering wheel by its spokes or resting your hands on the centre part of the wheel.

Passengers must not place their feet on the dashboard.

Do not smoke as deployment of the airbags can cause burns or the risk of injury from a cigarette or pipe.

Never remove or pierce the steering wheel or hit it violently.

Do not fit or attach anything to the steering wheel or dashboard, this could cause injuries with deployment of the airbags.

Lateral airbags

Use only approved covers on the seats, compatible with the deployment of the lateral airbags. For information on the range of seat covers suitable for your vehicle, you can contact a PEUGEOT dealer.

For more information on accessories, refer to "Other accessories" in section 6.

Do not fix or attach anything to the seat backs (clothing...). This could cause injury to the chest or arms if the lateral airbag is deployed.

Do not sit with the upper part of the body any nearer to the door than necessary.



Lateral airbags

This is a system which protects the driver and front passenger in the event of a serious side impact in order to limit the risk of injury to the chest.

Each lateral airbag is fitted in the front seat backrest frame, on the door side.

Deployment

It is deployed unilaterally in the event of a serious side impact applied to all or part of the side impact zone **B**, perpendicular to the longitudinal centreline of the vehicle on a horizontal plane and directed from the outside towards the inside of the vehicle.

The lateral airbag inflates between the front occupant of the vehicle and the corresponding door trim panel.

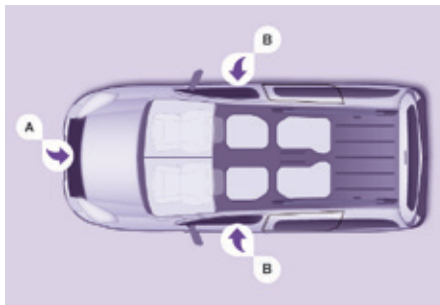

Impact detection zones

- A.** Front impact zone.
- B.** Side impact zone.

! In the event of a minor impact or bump on the side of the vehicle or if the vehicle rolls over, the airbag may not be deployed.

Operating fault



If this warning lamp comes on in the instrument panel, accompanied by an audible signal and a message in the screen, contact a PEUGEOT dealer or a qualified workshop to have the system checked. The airbags may no longer be deployed in the event of a serious impact.

Curtain airbags

This is a system which protects the driver and passengers (with the exception of the centre seat of row 2) in the event of a serious side impact in order to limit the risk of head injuries.

Each curtain airbag is incorporated in the pillars and the upper part of the passenger compartment.

Activation

It is triggered at the same time as the corresponding lateral airbag in the event of a serious side impact applied to all or part of the side impact zone **B**, perpendicular to the longitudinal centreline of the vehicle on a horizontal plane and directed from the outside towards the inside of the vehicle.

The curtain airbag inflates between the front or rear occupant of the vehicle and the windows.

Airbags

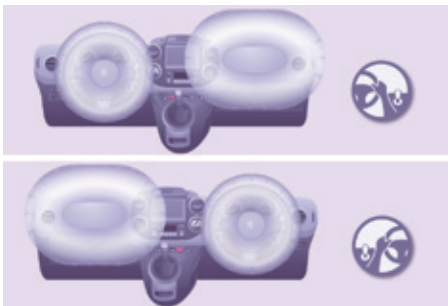

Front airbags

The front airbags are fitted in the centre of the steering wheel for the driver and in the dashboard for the front passenger.

Deployment

They are deployed, except the passenger's front airbag if it has been deactivated, in the event of a serious front impact applied to all or part of the front impact zone **A** in the longitudinal centreline of the vehicle on a horizontal plane directed from the front towards the rear of the vehicle.

The front airbag inflates between the front occupant of the vehicle and the dashboard to cushion their forward movement.



Deactivating the passengers front airbag

Only the passenger's front airbag can be deactivated.

- **With the ignition switched off**, insert the key into the passenger's front airbag deactivation switch.
- Turn it to the **"OFF"** position.
- Remove the key keeping the switch in the new position.



The passenger's front airbag warning lamp in the instrument panel remains on while the airbag is deactivated.

- ⚠ To ensure the safety of your child, it is essential to deactivate the passenger's front airbag when you install a rearward facing child seat on the front passenger seat. Otherwise, the child would risk being killed or seriously injured if the airbag were deployed.

Reactivation

In the **"OFF"** position, the passenger's front airbag will not be deployed in the event of an impact.

As soon as the child seat is removed, turn the passenger's front airbag switch to the **"ON"** position to reactivate the airbag and thus ensure the safety of your passenger in the event of an impact.

Front airbag fault



If this warning lamp comes on, accompanied by an audible signal and a message in the screen, consult a PEUGEOT dealer or a qualified workshop to have the system checked.



If the two airbag warning lamps are on continuously, do not install a rearward facing child seat and contact a PEUGEOT dealer or a qualified workshop.

CARRYING CHILDREN

General points

Although one of PEUGEOT's main criteria when designing your vehicle, the safety of your children also depends on you.

For maximum safety, please observe the following recommendations:

- in accordance with European regulations, **all children under the age of 12 or less than one and a half metres tall must travel in approved child seats suited to their weight**, on seats fitted with a seat belt or ISOFIX mountings*,
- **statistically, the safest seats in your vehicle for carrying children are the rear seats,**
- **a child weighing less than 9 kg must travel in the rearward facing position both in the front and in the rear.**



PEUGEOT recommends that children should travel in the **rear seats** of your vehicle:

- **rearward facing** up to the age of 3,
- **forward facing** over the age of 3.

* The regulations on carrying children are specific to each country. Refer to the legislation in force in your country.



CHILD SEAT AT THE FRONT

Rearward facing

When a rearward facing child seat is installed on the **front passenger seat**, the passenger's front airbag must be deactivated. Otherwise **the child risks being seriously injured or killed if the airbag is deployed.**

Adjust the vehicle's seat to:

- the fully back position, with the backrest straightened for a seat without height adjuster,
- the fully back and highest position, with the backrest straightened for a seat with height adjuster.

i Refer to the legislation in your country before installing your child in this seating position.



Forward facing

When a forward facing child seat is installed on the **front passenger seat**, the passenger's front airbag must remain active:

Adjust the vehicle's seat to:

- the fully back position, with the backrest straightened for a seat without height adjuster,
- the fully back position and highest position, with the backrest straightened for a seat with height adjuster.



Passenger seat in the fully back and highest position.

i Ensure that the seat belt is correctly tensioned.

For child seats with a support leg, ensure that this is in steady contact with the floor. If not, adjust the passenger seat.

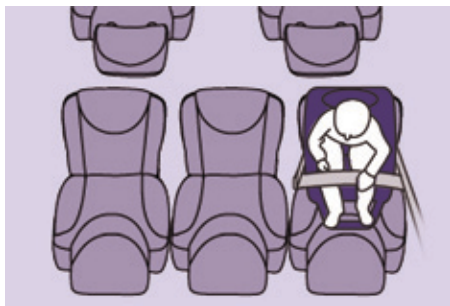

CHILD SEAT AT THE REAR

Rearward facing

When a rearward facing child seat is installed **on a rear passenger seat**, move the vehicle's front seat forwards and straighten the backrest so that the rearward facing child seat does not touch the vehicle's front seat.

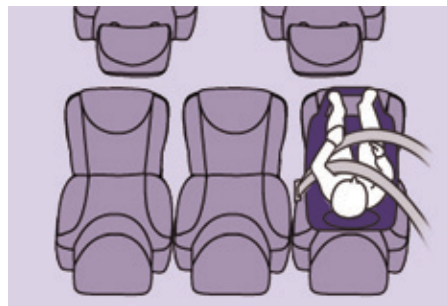

Forward facing

When a forward facing child seat is installed **on a rear passenger seat**, move the vehicle's front seat forwards and straighten the backrest so that the legs of the child in the forward facing child seat do not touch the vehicle's front seat.

i Ensure that the seat belt is correctly tensioned.

For child seats with a support leg, ensure that this is in firm contact with the floor.

Seats in row 3

When a child seat is installed **on a passenger seat in row 3**, put the backrests of the outer and centre seats in row 2 forward of the seat occupied by the child seat, in the table position, or if this is not sufficient, remove the seats in row 2 so that the child seat or the legs of the child do not touch the seats in row 2.

! A child seat with a support leg must never be installed on a **passenger seat in row 3**.



DEACTIVATING THE PASSENGER'S FRONT AIRBAG

I Never install a rearward facing child restraint system on a seat protected by an active front airbag. This could cause the death of the child or serious injury.

+ For information on deactivating the passenger's front airbag, refer to the "Airbags" section in this chapter.

The warning label present on both sides of the passenger's sun visor repeats this advice. In line with current legislation, the following tables contain this warning in all of the languages required.

AR	لا يجب أبدا تركيب نظام لإجلال الطفل الوجه باتجاه الورااء على مقعد سيارة مجهز بوسادة امان هوائية امامية مفعلة، فقد يؤدي هذا إلى التسبب ببنوت الطفل أو بإصابات خطيرة لديه.
BG	НИКОГА НЕ инсталирайте детско столче на седалка с АКТИВИРАНА предна ВЪЗДУШНА ВЪЗГЛАВНИЦА. Това може да причини СМЪРТ или СЕРИОЗНО НАРАНЯВАНЕ на детето.
CS	NIKDY neumistujte dětské zádržné zařízení orientované směrem dozadu na sedadlo chráněné AKTIVOVANÝM čelním AIRBAGEM. Hrozí nebezpečí SMRTI DÍTĚTE nebo VÁŽNĚHO ZRANĚNÍ.
DA	Brug ALDRIG en bagudvendt barnestol på et sæde, der er beskyttet af en AKTIV AIRBAG. BARNET risikerer at blive ALVORLIGT KVÆSTET eller DRÆBT.
DE	Montieren Sie auf einem Sitz mit AKTIVIERTEM Front-Airbag NIEMALS einen Kindersitz oder eine Babyschale entgegen der Fahrtrichtung, das Kind könnte schwere oder sogar tödliche Verletzungen erleiden.
EL	Μη χρησιμοποιείτε ΠΟΤΕ παιδικό κάθισμα με την πλάτη του προς το εμπρός μέρος του αυτοκινήτου, σε μια θέση που προστατεύεται από ΜΕΤΩΠΙΚΟ αερόσακο που είναι ΕΝΕΡΓΟΣ. Αυτό μπορεί να έχει σαν συνέπεια το ΘΑΝΑΤΟ ή το ΣΟΒΑΡΟ ΤΡΑΥΜΑΤΙΣΜΟ του ΠΑΙΔΙΟΥ
EN	NEVER use a rearward facing child restraint on a seat protected by an ACTIVE AIRBAG in front of it, DEATH or SERIOUS INJURY to the CHILD can occur
ES	NO INSTALAR NUNCA un sistema de retención para niños de espaldas al sentido de la marcha en un asiento protegido mediante un AIRBAG frontal ACTIVADO, ya que podría causar lesiones GRAVES o incluso la MUERTE del niño.
ET	Ärge MITTE KUNAGI paigaldage "seljaga sõidusuunas" lapseistet juhi kõrvalistmele, mille ESITURVAPADI on AKTIVEERITUD. Turvapadja avanemine võib last TÕSISELT või ELUOHTLIKULT vigastada.
FI	ÄLÄ KOSKAAN aseta lapsen turvaistuinta selkå ajosuuntaan istuimelle, jonka edessä suojana on käyttöön aktivoitu TURVATYYNY. Sen laukeaminen voi aiheuttaa LAPSEN KUOLEMAN tai VAKAVAN LOUKKAANTUMISEN.
FR	NE JAMAIS installer de système de retenue pour enfants faisant face vers l'arrière sur un siège protégé par un COUSSIN GONFLABLE frontal ACTIVÉ. Cela peut provoquer la MORT de l'ENFANT ou le BLESSER GRAVEMENT
HR	NIKADA ne postavljati dječju sjedalicu leđima u smjeru vožnje na sjedalo zaštićeno UKLJUČENIM prednjim ZRAČNIM JASTUKOM. To bi moglo uzrokovati SMRT ili TEŠKU OZLJEDU djeteta.
HU	SOHA ne használjon menetiránynak háttal beszerelt gyermekülést AKTIVÁLT (BEKAPCSOLT) FRONTLÉGSÁKKAL védett ülésen. Ez a gyermek HALÁLÁT vagy SÜLYÖS SÉRÜLÉSET okozhatja.
IT	NON installare MAI seggiolini per bambini posizionati in senso contrario a quello di marcia su un sedile protetto da un AIRBAG frontale ATTIVATO. Ciò potrebbe provocare la MORTE o FERITE GRAVI al bambino.
LT	NIEKADA neįrengkite vaiko prietaikymo priemonės su atgal atgręžtu vaiku ant sėdynės, kuri saugoma VEIKIANČIOS priekinės ORO PAGALVĖS. Išsiskleidus oro pagalvei vaikas gali būti MIRTINAI arba SUNKIAI TRAUMUOTAS.

LV	NEKAD NEuzstādiet uz aizmuguri vērstu bērnu sēdekļi priekšējā pasažiera sēdvietā, kurā ir AKTIVIZĒTS priekšējais DROŠĪBAS GAISA SPILVENS. Tas var izraisīt BĒRNA NĀVI vai radīt NOPIETNUS IEVAINOJUMUS.
MT	Qatt m'ghandek thalli tifel/tifla marbut f'siggu dahru lejn l-Airbag attiva, ghaliex tista' tikkawza korriment serju jew anke mewt lit-tifel/tifla
NL	Plaats NOOIT een kinderzitje met de rug in de rijrichting op een zitplaats waarvan de AIRBAG is INGESCHAKELD. Bij het afgaan van de airbag kan het KIND LEVENSGEVAARLIJK GEWOND RAKEN
NO	Installer ALDRI et barnesete med ryggen mot kjøreretningen i et sete som er beskyttet med en frontal AKTIVERT KOLLISJONSPUTE, BARNET risikerer å bli DREPT eller HARDT SKADET.
PL	NIGDY nie instalować fotelika dziecięcego w pozycji "tyłem do kierunku jazdy" na siedzeniu wyposażonym w CZŁOWĄ PODUSZKĘ POWIETRZNĄ w stanie AKTYWNYM. Może to doprowadzić do ŚMIERCI DZIECKA lub spowodować u niego POWAŻNE OBRAŻENIA CIAŁA.
PT	NUNCA instale um sistema de retenção para crianças de costas para a estrada num banco protegido por um AIRBAG frontal ACTIVADO. Esta instalação poderá provocar FERIMENTOS GRAVES ou a MORTE da CRIANÇA.
RO	Nu instalati NICIODATA un sistem de retenere pentru copii, dispus cu spatele in directia de mers, pe un loc din vehicul protejat cu AIRBAG frontal ACTIVAT. Aceasta ar putea provoca MOARTEA COPILULUI sau RANIREA lui GRAVA.
RU	ВО ВСЕХ СЛУЧАЯХ ЗАПРЕЩАЕТСЯ использовать обращенное назад детское удерживающее устройство на сиденье, защищенном ФУНКЦИОНИРУЮЩЕЙ ПОДУШКОЙ БЕЗОПАСНОСТИ, установленной перед этим сиденьем. Это может привести к ГИБЕЛИ РЕБЕНКА или НАНЕСЕНИЮ ЕМУ СЕРЬЕЗНЫХ ТЕЛЕСНЫХ ПОВРЕЖДЕНИЙ
SK	NIKDY neinštalujte detské zádržné zariadenie orientované smerom dozadu na sedadlo chránené AKTIVOVANÝM čelným AIRBAGOM. Mohlo by dôjsť k SMRTELNEMU alebo VÁŽNEMU PORANENIU DIEŤAŤA.
SL	NIKOLI ne nameščajte otroškega sedeža s hrbtom v smeri vožnje, če je VARNOSTNA BLAZINA pred sprednjim sopolnikovim sedežem AKTIVIRANA. Takšna namestitve lahko povzročijo SMRT OTROKA ali HUDE POŠKODBE.
SR	NIKADA ne koristite dečje sedišta koje se okreće unazad na sedištu zaštićenim AKTIVNIM VAZDUŠNIM JASTUKOM ispred njega, jer mogu nastupiti SMRT ili OZBILJNA POVREDA DETETA.
SV	Passagerarkrockkudden fram MÅSTE vara avaktiverad om en bakåtvänd bilbarnstol installerad på denna plats. Annars riskerar barnet att DÖDAS eller SKADAS ALLVARLIGT.
TR	KESİNLKLE HAVA YASTIĞI AKTİF olan ön koltuğa yüzü arkaya dönük bir çocuk koltuğu yerleştirmeyiniz. Bu ÇOCUĞUN ÖLMESİNE veya ÇOK AĞIR YARALANMASINA sebep olabileir.

RECOMMENDED SEATS

PEUGEOT offers a range of recommended child seats which are **secured using a three point seat belt**.

Group 0+: from birth to 13 kg



L1

"ROMER Baby-Safe Plus"

Installed in the rearward facing position.

Groups 2 and 3: from 15 to 36 kg



L4

"KLIPPAN Optima"

From 22kg (about 6 years), the booster is used on its own.



L5

"RÖMER KIDFIX"

Can be fixed on the vehicle's ISOFIX mountings.

The child is restrained by the seat belt.

Child safety

SEATS WITH A SUPPORT LEG

Care must be taken when installing a child seat with a support leg in the vehicle. In particular you should look for the presence of a storage compartment below the rear seat footwells.

The centre rear seat does not have a storage compartment below the footwell. You can therefore easily fit a child seat with a support leg, whether installed with the ISOFIX mountings or using the 3 point seat belt.

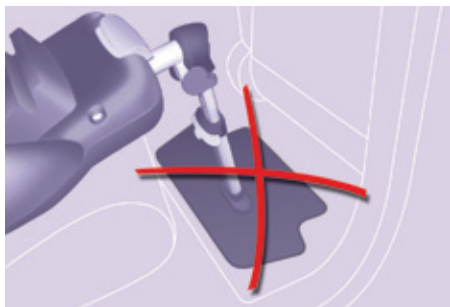

! Do not place the support leg on the storage compartment cover; it might break in a serious impact.

Where the adjustments of the support leg allow it, we suggest two other possibilities for installation.



At the bottom of the storage compartment

If the support leg is long enough, you can adjust it so that it contact the bottom of the storage compartment. Remove all objects from the storage compartment before installing the support leg.







Away from the storage compartment area

If the support leg is long enough and can be inclined sufficiently (always by following the recommendations given in the installation instructions for the child seat), you can position the support leg so that it contacts the floor away from the storage compartment. Adjust the longitudinal position of the front or rear seat to obtain a satisfactory position for the support leg away from the storage compartment.

! If you cannot position the support leg in the way described, you should not fit a child seat with support leg to the seat.

LOCATIONS FOR CHILD SEATS SECURED WITH THE SEAT BELT

In accordance with European regulations, this table indicates the options for installing child seats secured using a seat belt and universally approved (a) according to the weight of the child and the seat in the vehicle.

Seat(s)			Weight of the child and indicative age			
			Under 13 kg (groups 0 (b) and 0+) Up to approx 1 year	From 9 to 18 kg (group 1) 1 to 3 years approx	From 15 to 25 kg (group 2) 3 to 6 years approx	From 22 to 36 kg (group 3) 6 to 10 years approx
Row 1 (c) (d)	Passenger seat		U	U	U	U
Row 2 (e) (5 and 7 seats)	Outer seats		U*	U*	U	U
	Centre seat		U	U	U	U
Row 3 (f) (g) (7 seats)	All seats		U**	U**	U	U

* A child seat with support leg must never be installed on an outer passenger seat in row 2, unless you are able to install it in line with the recommendations under "Installing a child seat with a support leg".

** A child seat with support leg must never be installed on a passenger seat in row 3.

U: seat suitable for the installation of a child seat secured using the seat belt and universally approved, rearward facing and/or forward facing.

Child safety

- (a) Universal child seat: child seat that can be installed in any vehicle using the seat belt.
- (b) Group 0: from birth to 10 kg. Cots and baby carriers cannot be installed on the front passenger seat or in row 3. When installed in row 2, they may prevent the use of one or more seat in this row.
- (c) Refer to the legislation in force in your country before installing your child on this seat.
- (d) When a rearward facing child seat is installed on a **front passenger seat**, the passenger's front airbag must be deactivated. Otherwise, **the child would risk being seriously injured or killed if the airbag is deployed.**
- (e) When a child seat is installed at the rear, forward facing or rearward facing, move the vehicle's seats in the row in front forwards and straighten their backrests to leave enough space for the child seat or the child's legs.
- (f) Put the backrests of the outer and centre seats in row 2, located in front of seat occupied by a child seat, in the table position, or if this is not sufficient, remove the seats in row 2, so that the child seat or the child's legs do not touch the seats in row 2.
- (g) If the seats in row 3 are occupied, do not leave a child seat installed on the foldable row 2 seat, to allow easy access to row 3.

i Remove and stow the heads restraint, before installing a child seat with backrest on a passenger seat.

Refit the head restraint once the child seat has been removed.

When a forward facing child seat is installed on a **front passenger seat**, the passenger's front airbag must remain active.

ISOFIX MOUNTINGS

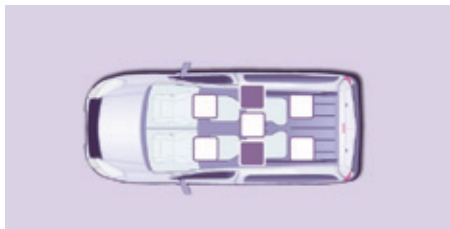

Your vehicle has been approved in accordance with the latest ISOFIX regulation.

The mountings comprise three rings for each seat.



Two front rings **A**, located between the vehicle seat backrest and cushion, indicated by a marking.



A rear ring **B**, located on the back of the vehicle's seat backrest, for securing the upper strap referred to as the Top Tether.

The Top Tether is used to secure the upper strap of child seats that have one. This arrangement limits the forward tipping of the child seat in the event of a frontal impact.

This ISOFIX mounting system guarantees you fast, reliable and safe fitting of the child seat in your vehicle.

The ISOFIX child seats are fitted with two latches which are secured on the two front rings **A**.

Some also have an upper strap which is attached to the rear ring **B**.

To secure the child seat to the Top Tether:

- remove and stow the head restraint before installing the child seat in this seating position (refit it once the child seat has been removed),
- pass the upper strap of the child seat over the top of the seat backrest, between the apertures for the head restraint rods,
- secure the hook on the upper strap to the rear ring,
- tighten the upper strap.

i The incorrect installation of a child seat in a vehicle compromises the protection of the child in the event of an accident.

i Follow strictly the instructions for fitting child seats contained in the manufacturer's installation guide.

Refer to the table for information on the installation of ISOFIX child seats in your vehicle.

Recommended ISOFIX seat

"ISOFIX RÖMER DUO plus"
(size category **B1**)

Group 1: from 9 to 18 kg



Installed only in the forward facing position.
Secured to rings **A**, as well as ring **B**,
called the Top Tether, using an upper strap.
Three seat body angles: sitting, reclining, lying.

This child seat can also be used on seats which are not fitted with ISOFIX mountings.

In this case, it must be attached to the vehicle seat using the three point seat belt.

Follow the instructions for fitting the child seat given in the seat manufacturer's installation guide.

LOCATIONS FOR CHILD SEATS ISOFIX

In accordance with European regulations, this table indicates the options for the installation of ISOFIX child seats on the vehicle seats fitted with ISOFIX mountings.

In the case of the universal and semi-universal ISOFIX child seats, the child seat's ISOFIX size category, determined by a letter from **A** to **G**, is indicated on the child seat next to the logo ISOFIX.

		Weight of the child / indicative age									
		Less than 10 kg (group 0) Up to 6 months approx		Less than 10 kg (group 0) Less than 13 kg (group 0+) Up to 1 year approx			From 9 to 18 kg (group 1) From 1 to 3 years approx				
Type of ISOFIX child seat		Infant car seat		rearward facing			rearward facing		forward facing		
ISOFIX size category		F	G	C	D	E	C	D	A	B	B1
Row 2 (5 and 7* seats)	Outer seats**	IL-SU		IL-SU			IL-SU		IUF, IL-SU		
	Centre seat	Not ISOFIX									
Row 3 (7 seats)	All seats	Not ISOFIX									

* In the 7 seat version, all three seats in row 2 must be present when child seats are installed.

** A child seat with support leg must never be installed on an outer passenger seat in row 2, unless you are able to install it in line with the recommendations under "Installing a child seat with a support leg".

IUF: seat suitable for the installation of an ISOFIX **U**niversal child seat, **F**orward facing and secured with an upper strap.

IL-SU: seat suitable for the installation of a ISOFIX **S**emi-**U**niversal child seat, either.

- rearward facing equipped with an upper strap or a support leg,
- forward facing equipped with a support leg,

- a cot equipped with an upper strap or a support leg.

To attach the upper strap, refer to chapter 5, "ISOFIX mountings" section.

i Remove and stow the head restraint before installing a child seat with a backrest on a passenger seat.

Refit the head restraint once the child seat has been removed.

Child safety

ADVICE ON CHILD SEATS

The incorrect installation of a child seat in a vehicle compromises the child's protection in the event of an accident.

Check that there is no seat belt or seat belt buckle under the child seat, as this could destabilise the seat.

Remember to fasten the seat belts or the child seat harnesses **keeping the slack** relative to the child's body **to a minimum**, even for short journeys.

For the installation of a child seat using the seat belt, ensure that the seat belt is well tensioned on the child seat and that it is holding the child seat firmly against the vehicle's seat. If the passenger seat is adjustable, move it forward if necessary.

At the rear, always leave sufficient space between the front seat and:

- a rearward facing child seat,
- the feet of a child seated in a forward facing child seat.

For this, move the front seat forward and, if necessary, straighten its backrest as well.

For an installation in row 3, put the backrests of the outer and centre seats in row 2 in the table position, or remove these seats in row 2, so that the child seat or the child's legs do not touch the seats in row 2.

For the optimum installation of a forward facing child seat, ensure that the back of the child seat is as close as possible to the backrest of the vehicle's seat, or in contact if possible.

The head restraint must be removed before installing a child seat with a backrest on the passenger seat.

Ensure that the head restraint is stowed or attached securely so that it is not thrown around the vehicle in the event of sharp braking.

Refit the head restraint as soon as the child seat is removed.

Children at the front

The legislation on carrying a child on the front passenger seat is specific to each country. Refer to the legislation in force in your country.

Deactivate the passenger's airbag when a rearward facing child seat is installed on the front seat.

Otherwise, the child would risk being seriously injured or killed if the airbag were deployed.

Installing a booster seat

The chest part of the seat belt must be positioned on the child's shoulder without touching the neck.

Ensure that the lap part of the seat belt passes correctly over the child's thighs. PEUGEOT recommends the use of a booster seat which has a back, fitted with a seat belt guide at shoulder level.

As a safety precaution, never leave:

- one or more children alone and unsupervised in a vehicle,
- a child or an animal in a vehicle which is exposed to the sun, with the windows closed,
- the keys within reach of children inside the vehicle.

To prevent accidental opening of the doors, use the "Child Lock".

Take care not to open the rear windows by more than one third.

To protect young children from the rays of the sun, fit side blinds to the rear windows.

CHILD LOCK



This prevents opening of the sliding side doors from the inside.

Manual

A label indicates the position of the lever and the state of the child lock.

- Open fully past the point of resistance.
- Tilt the lever, located on the rear section of the door.

Electric



With the ignition on, press this button in the middle of the dashboard.

Indicator lamp on = child lock on.

Please note: this system is independent of the central locking control.

! Always remove the ignition key when leaving the vehicle, even for a short time.

It is advisable to check the state of the child lock each time the ignition is switched on.

In the event of a serious impact the electric child lock is deactivated automatically.



TOWING A TRAILER, A CARAVAN...

+ For more information about weights and towed loads, refer to chapter 9, "Weights" section.

Driving advice

A towed vehicle must free wheel: gearbox in neutral.

Distribution of loads

Distribute the load in the trailer so that the heaviest objects are as close as possible to the axle and the nose weight is close to the maximum authorised without, however, exceeding it.

Cooling

Towing a trailer on a slope increases the coolant temperature.

As the fan is electrically controlled, its cooling capacity is not dependent on the engine speed.

You should therefore use a high gear to lower the engine speed and reduce your speed.

In all cases, pay attention to the coolant temperature.

Good Practice

In certain cases of particularly arduous use (towing the maximum load up a steep slope in high temperatures), the engine automatically limits its power. In this case, the air conditioning is automatically cut off to save engine power.



If the coolant temperature warning lamp comes on, stop the vehicle and switch off the engine as soon as possible.

 Chapter 7, "Levels" section.

Tyres

Check the tyre pressures of the towing vehicle and of the trailer, observing the recommended pressures.

 Chapter 9, "Identification markings" section.

Brakes

Towing increases the braking distance. Drive at a moderate speed, change down early and brake gradually.

Side wind

Sensitivity to side wind is increased. Drive smoothly and at a moderate speed.

ABS/DSC

The ABS or DSC systems only control the vehicle, not the trailer or caravan.

Parking sensors

The rear parking sensors system does not function while the vehicle is towing.

Towbar

We recommend the use of genuine PEUGEOT towbars and their wiring harnesses, which have been tested and approved from the design stage of your vehicle, and that you entrust the fitting of this equipment to a PEUGEOT dealer.

If this equipment is not fitted by a PEUGEOT dealer, it is imperative that it is fitted using the electrical pre-equipment installed at the rear of the vehicle and in accordance with the manufacturer's instructions.

In accordance with the general instructions a reminder of which has been given above, we draw your attention to the risk associated with fitting a towbar or electrical accessory not recommended by PEUGEOT. Fitting such equipment could result in the failure of your vehicle's electronic system. Please obtain information from the Manufacturer before fitting this type of equipment.

Towing a trailer

TOWBAR WITH SWAN NECK TOWBALL, LOCKABLE AND QUICKLY DETACHABLE

Presentation

This swan neck towbar, delivered assembled, can be removed and fitted easily. No tools are needed.

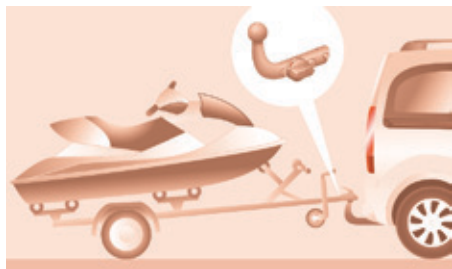

Instructions for fitting and before every use

Check that the swan neck is correctly locked by verifying the following points:

- the green mark on the locking wheel is visible,
- the safety lock on the locking wheel is directed toward the rear,
- the safety lock is closed and the key removed; the locking wheel can no longer be operated,
- the swan neck must no longer move at all in its carrier.

When hooking up the trailer, don't forget to connect the trailer harness.

Fitting

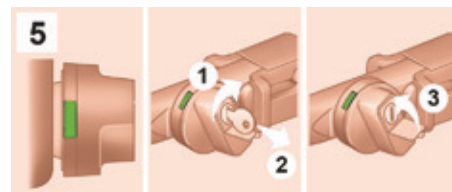
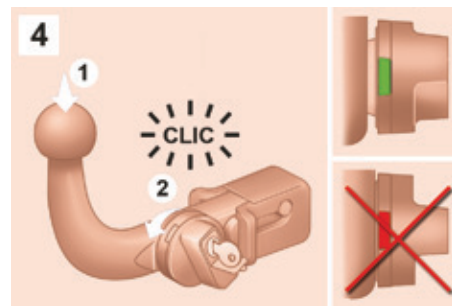
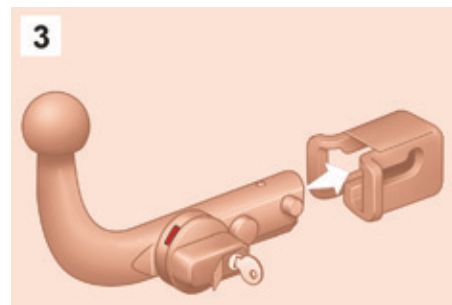
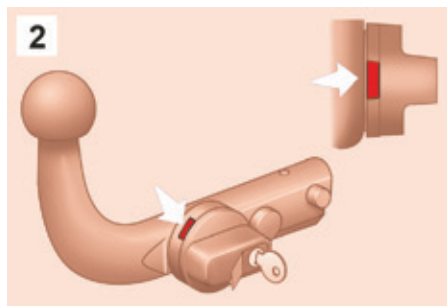
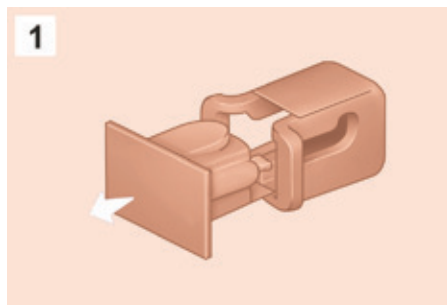

i **During use**

Never unlock the device when a trailer or load carrier is fitted to the swan neck.

i **After use**

For journeys made without a trailer or load carrier, the swan neck must be removed and the blanking plug inserted in the carrier. This measure applies particularly if the swan neck could hinder visibility of the number plate or lighting.

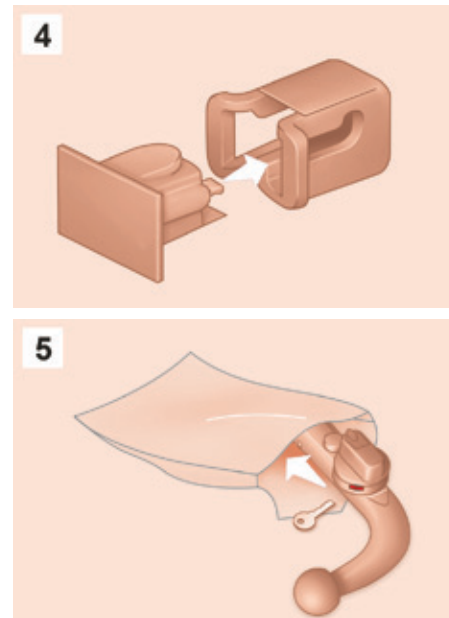
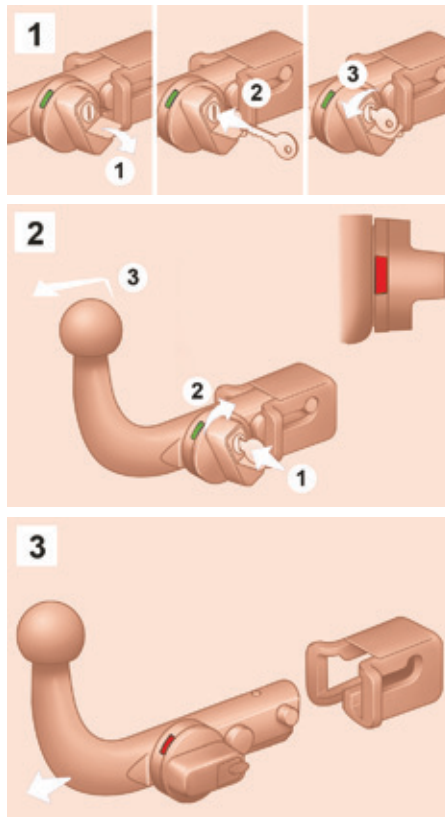
Removal**Maintenance**

Correct operation is only possible if the swan neck and its carrier remain clean.

Before cleaning the vehicle with a high pressure jet wash, the swan neck must be removed and the blanking plug inserted in the carrier.

Equipment

OTHER ACCESSORIES

These accessories and parts, having been tested and approved for reliability and safety, are all adapted to your vehicle. A wide range of recommended accessories and genuine parts is available.

A further range is also available, structured around comfort, leisure and maintenance:

Anti-theft alarm, window etching, first aid kit, high visibility vest, front and rear parking sensors, warning triangle, security bolts for alloy wheels, ...

Seat covers compatible with airbags for the front seats, bench seat, rubber mats, carpet mats, snow chains, blinds, tailgate bicycle carrier, ...

To prevent the mat from becoming caught under the pedals:

- ensure that the mat and its fixings are positioned correctly,
- never fit one mat on top of another.

Audio equipment, hands-free kit, speakers, CD changer, satellite navigation system, USB box, Video kit, ...

Regardless of the audio and telematic equipment offered on the market, the technical constraints associated with the fitting of equipment of these product groups mean that the special features of the equipment and its compatibility with the capacities of your vehicle's standard equipment must be taken into account. Please ask a PEUGEOT dealer for more information before fitting such equipment.

Maximum weights on bars

- Transverse bars on longitudinal bars: 75 Kg (these bars are not compatible with the Zénith roof).

Installing radiocommunication transmitters

You are advised to contact a PEUGEOT dealer before installing accessory radiocommunication transmitters with external aerial on your vehicle.

The PEUGEOT dealer network will inform you of the specification (frequency band, maximum output power, aerial position, specific conditions of installation) of the transmitters which can be fitted, in accordance with the Motor Vehicle Electromagnetic Compatibility Directive (2004/104/EC).

Front mud flaps, rear mud flaps, 15/17 inch alloy wheels, wheelarch trim, leather steering wheel, ...

Screenwash, interior and exterior cleaning and maintenance products, spare bulbs, ...

 The fitting of electrical equipment or accessories which are not recommended by PEUGEOT may result in a failure of your vehicle's electronic system. Please note this specific warning. You are advised to contact a dealer to be shown the range of recommended equipment or accessories.

Depending on the country in which the vehicle is sold, it is compulsory to have a high visibility vest, warning triangle and spare bulbs available in the vehicle.

PEUGEOT & TOTAL, A PARTNERSHIP TO DELIVER BETTER PERFORMANCE!

2015 was marked by PEUGEOT's return to Rally-Raid, one of the most difficult motorsport disciplines in the world. To obtain the best performance in these trials, PEUGEOT Sport chose TOTAL QUARTZ for the PEUGEOT 2008 DKR, a lubricant of high technology which protects the engine in the most severe conditions.

TOTAL QUARTZ protects your engine against the effects of time.

TOTAL QUARTZ Ineo First is a high performance lubricant, the result of work done together by PEUGEOT and TOTAL R&D. Specially formulated for the engines in PEUGEOT vehicles, its innovative technology significantly reduces CO₂ emissions and keeps your engine clean.



Opening the bonnet



OPENING THE BONNET

On the inside

Pull the lever below the dashboard towards you. The bonnet is released.



On the outside

Raise the bonnet slightly by reaching in a flat hand, palm down, to make access to the lever easier.

With this hand, push the safety catch to the left. Raise the bonnet.



Bonnet stay

Secure the stay in its location, identified by a sticker on the right-hand side of the vehicle, to hold the bonnet open.

Before closing the bonnet, put the stay back in its clip without using excessive force.

To close

Lower the bonnet and release it at the end of its travel. Check that the bonnet is secure.

Avoid opening the bonnet in strong winds.

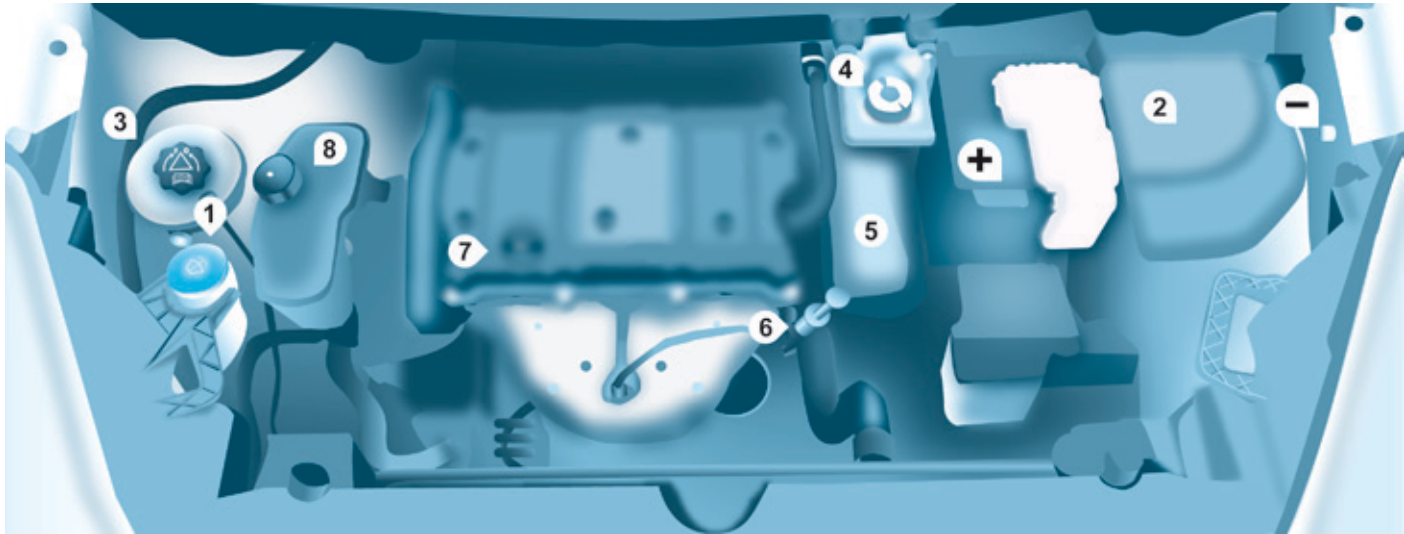

PETROL ENGINE

Take care when working under the bonnet.

- | | | |
|--------------------------------|--------------------------------------|------------------------------------|
| 1. Screenwash fluid reservoir. | 4. Brake and clutch fluid reservoir. | 7. Engine oil filler cap. |
| 2. Fusebox. | 5. Air filter. | 8. Power steering fluid reservoir. |
| 3. Engine coolant header tank. | 6. Engine oil dipstick. | |

i Battery connections:

- + Positive terminal.
- Negative point (earth).

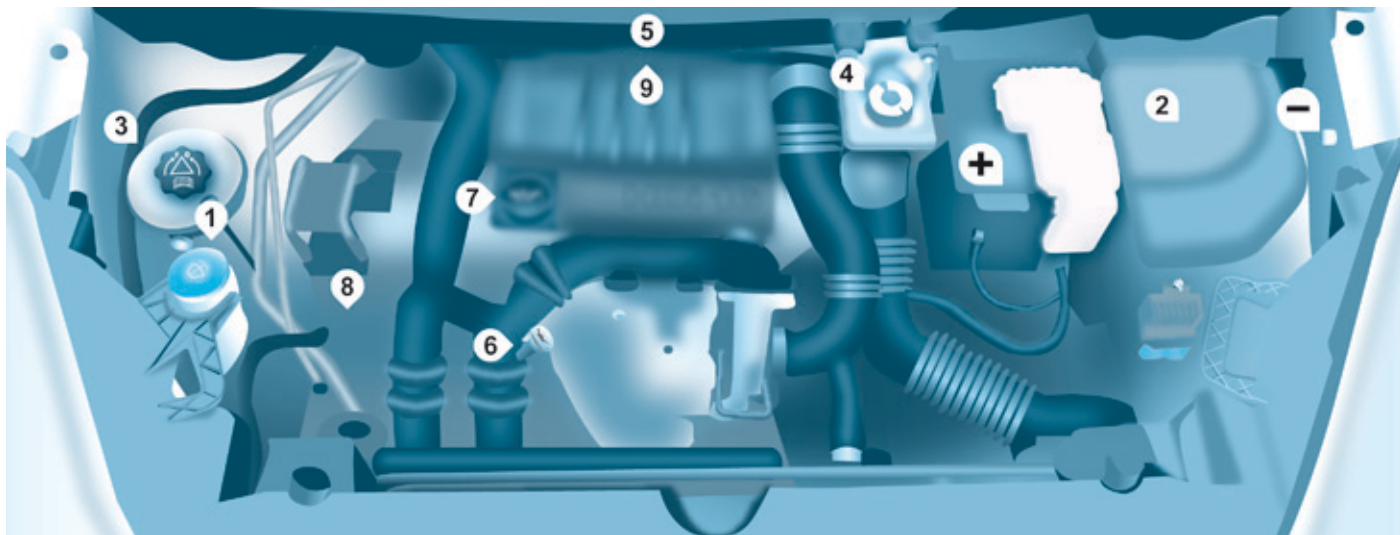

DIESEL ENGINE

Take care when working under the bonnet.

- | | | |
|--------------------------------|--------------------------------------|--|
| 1. Screenwash fluid reservoir. | 4. Brake and clutch fluid reservoir. | 8. Power steering fluid reservoir. |
| 2. Fusebox. | 5. Air filter. | 9. Priming pump
(except BlueHDi engines). |
| 3. Engine coolant header tank. | 6. Engine oil dipstick. | |
| | 7. Engine oil filler cap. | |

i Battery connections:

- + Positive terminal.
- Negative point (earth).

LEVELS

i These regular maintenance operations will keep your vehicle in good working order. Ask for advice from a PEUGEOT dealer or refer to the warranty and maintenance record in the handbook pack.

! If you have to remove / refit the engine style cover, handle it with care to avoid damaging the fixing clips.

Oil level

It is recommended that the oil level be checked every 3 000 miles (5 000 km) and topped up if necessary between oil changes.

Check the level with the vehicle level, engine cold, using the dipstick.

Dipstick

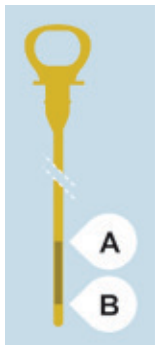

There are two marks on the dipstick:

A = maximum

If you fill past this mark, contact a PEUGEOT dealer or a qualified workshop.

B = minimum

Never allow the level to fall below this mark.

To maintain the reliability of engines and emission control systems, the use of additives in engine oil is prohibited.

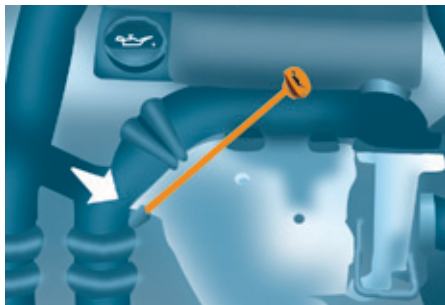

Oil change

This must be carried out at the intervals specified in the manufacturer's servicing schedule. Ask for advice from a PEUGEOT dealer.

Remove the dipstick before filling.

Check the level after filling (never exceed the max mark).

Refit the oil filler cap before closing the bonnet.

Viscosity selection

In all cases, the oil selected must meet the requirements specified in the manufacturer's service schedule.



Changing the brake fluid

The brake fluid must be changed at the intervals stated, according to the manufacturer's servicing schedule.

Use fluids recommended by the manufacturer, which meet the DOT4 standard.

The level must be between the MIN and MAX marks on the reservoir.

If fluid has to be added frequently, this indicates a fault which must be checked by a PEUGEOT dealer or a qualified workshop as soon as possible.

Warning lamps

+ Checks using the warning lamps in the instrument panel is described in chapter 3, "Instruments and controls" section.

Levels

Cooling system

Only use the fluid recommended by the manufacturer.

Otherwise, you risk seriously damaging your engine.

When the engine is warm, the temperature of the coolant is controlled by the engine fan. As this fan can operate with the ignition key removed and because the cooling system is pressurised, wait for at least one hour after the engine has stopped before carrying out any work.

Slacken the cap by 1/4 of a turn to release the pressure to prevent any risk of scalding. When the pressure has dropped, remove the cap and top up the level with coolant.

If fluid has to be added frequently, this indicates a fault which must be checked by a PEUGEOT dealer as soon as possible.

Topping up

The level must be between the MIN and MAX marks on the expansion bottle. If more than 1 litre of fluid is required to top up the level, have the system checked by a PEUGEOT dealer or a qualified workshop.

Power steering fluid level

The vehicle must be parked on level ground with the engine cold. Unscrew the cap integrated with the gauge and check the level which must be between the MIN and MAX marks.

Screenwash level

For best quality cleaning and for your safety, we would advise that you use products of the PEUGEOT range.

For optimum cleaning and to avoid freezing, this fluid must not be topped up or replaced with plain water.

Capacity of the screenwash reservoir: approximately 3 litres.



Diesel additive level (Diesel with particle filter)

The minimum level of this additive is indicated by lighting of the service warning lamp, accompanied by an audible signal and a message in the screen.

When this occurs with the engine running it is due to the start of saturation of the particle filter (exceptionally prolonged urban type driving conditions: low speed, long traffic jams, ...).

In order to regenerate the filter, you are advised to drive at a speed higher than 40 mph (60 km/h) for at least five minutes as soon as possible, when traffic conditions permit (until the message disappears and the service warning lamp goes off).

During regeneration of the particle emission filter, the noise of a relay operating may be heard under the dashboard.

If the message is still displayed and if the service warning lamp remains on, contact a PEUGEOT dealer or a qualified workshop.

Topping up

This additive must be topped up by a PEUGEOT dealer or a qualified workshop without delay.

Waste products

Avoid prolonged contact of used oil with the skin.

Brake fluid is harmful to health and very corrosive.

Do not dispose of used oil, brake fluid or coolant into drains or into the ground but into the containers dedicated to this use at a PEUGEOT dealer (France) or an authorised waste disposal site.

CHECKS

Battery

At the start of summer or winter, have your battery checked by a PEUGEOT dealer or a qualified workshop.

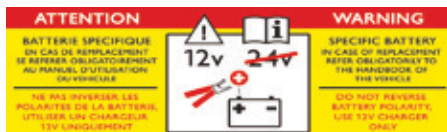

Brake pads

Brake pad wear depends on the style of driving, in particular for vehicles which are used in town, over short distances. It may be necessary to check the thickness of the pads, even between services.

Unless there is a leak on the circuit, a drop in the brake fluid level indicates that the brake pads are worn.

Brake disc / drum wear

For information on checking the brake disc / drum wear, contact a PEUGEOT dealer.

Parking brake

Where the parking brake travel is too great or there is a reduction in the performance of the system, the parking brake should be adjusted, even between services.

Have the system checked by a PEUGEOT dealer or a qualified workshop.

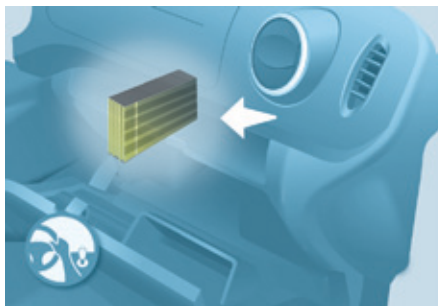

Carbon filter and passenger compartment filter

An access flap allows replacement of the filters.

The carbon filter permits continuous and effective filtering of dust.

If the passenger compartment filter becomes blocked, this may reduce the performance of the air conditioning system and generate unpleasant odours.

We recommend the use of a combined passenger compartment filter. By means of its second special active filter, it contributes to the purification of the air breathed by the occupants and the cleanness of the passenger compartment (reduction of allergic symptoms, unpleasant odours and greasy deposits).

Refer to the servicing and warranty booklet for the replacement interval for these components.

Depending on the environment (dusty atmosphere...) and the use of the vehicle (urban driving...), change them twice as often if necessary.

Oil filter

Change the filter regularly in accordance with the manufacturer's servicing schedule.

Particle filter (Diesel)

Maintenance of the particle filter must be carried out by a PEUGEOT dealer.

On acceleration after the vehicle has been running for a prolonged period at very low speed or at idle, you may, in exceptional circumstances, notice the emission of water vapour at the exhaust. This water vapour does not have any adverse effect on vehicle handling or the environment.

Checks

Bleeding water from the Diesel filter



If this warning lamp comes on, bleed the filter. Otherwise bleed regularly each time the engine oil is changed.

To drain the water, unscrew the bleed screw located on the filter.

Operate until all of the water no longer flows in the transparent pipe, then tighten the bleed screw.

i HDi engines use advanced technology. All work requires special training, so should be entrusted to a PEUGEOT dealer.

Depending on country of sale.

Manual gearbox

Have the level checked in accordance with the manufacturer's servicing schedule.

Good practice

Only use products recommended by PEUGEOT or products of equivalent quality and specification.

In order to optimise the operation of units as important as the braking system, PEUGEOT selects and offers specific products.

i In order to avoid damaging the electrical units, we strongly advise you not to use high pressure washing to clean the engine compartment.

After washing the vehicle dampness, or in winter, ice may form on the brake discs and pads: braking efficiency may be reduced. Make some light brake applications to dry and de-ice the brakes.



REFUELLING

Low fuel level



When the low fuel level is reached, this warning lamp comes on.

You then have **approximately 8 litres** of fuel remaining.

Fill up without delay to avoid running out of fuel.

Never risk driving until you run out of fuel as this may damage the emissions control and injection systems.

Filling

The fuel tank must be filled **with the engine off**.

- Open the fuel filler flap.
- Insert the key, then turn it a quarter turn.
- Remove the cap and hook it onto the clip located on the inside of the flap.

A label affixed to the inside of the flap reminds you of the type of fuel to be used.

You must fill with at least 5 litres of fuel for it to be registered by the fuel gauge. When the fuel filler cap is opened, there may be a slight inrush of air. This vacuum is entirely normal and is due to the sealing of the fuel system.

When filling the fuel tank, do not continue after the 3rd cut-off of the nozzle. This could cause malfunctions.

The capacity of the fuel tank is approximately 60 litres (or 55 litres according to version).

- After filling the fuel tank, lock the cap and close the flap.

I When filling with fuel, a mechanical system prevents opening of the left-hand side door. When the fuel filler flap is open, ensure that no one tries to slide this door. Once the flap has been closed, the sliding side door may jam, push the door to close it then open it.

Fuel

Fuel used for petrol engines

The petrol engines are compatible with bio-fuels that conform to current and future European standards and can be obtained from filling stations:

- Petrol that meets the EN228 standard, mixed with a bio-fuel meeting the EN15376 standard.

E5

The only petrol additives authorised for use are those that meet the B715001 standard.

E10

Travelling abroad

Certain fuels could damage the engine of your vehicle. In certain countries, the use of a particular fuel may be required (specific octane rating, specific sales name...) to ensure correct operation of the engine.

For any additional information, contact your dealer.

Fuel used for Diesel engines

The Diesel engines are compatible with biofuels that conform to current and future European standards and can be obtained from filling stations:

B7

- Diesel fuel that meets standard EN590 mixed with a biofuel that meets standard EN14214 (possibly containing up to 7 % Fatty Acid Methyl Ester),

B10

- Diesel fuel that meets standard EN16734 mixed with a biofuel that meets standard EN14214 (possibly containing up to 10 % Fatty Acid Methyl Ester),

XTL

- Paraffinic Diesel fuel that meets standard EN15940 mixed with a biofuel that meets standard EN14214 (possibly containing up to 7 % Fatty Acid Methyl Ester).

B20

B30

The use of B20 or B30 fuel meeting standard EN16709 is possible in your Diesel engine. However, this use, even occasional, requires strict application of the special servicing conditions referred to as "Arduous conditions".

For more information, contact a PEUGEOT dealer or a qualified workshop.

 The use of any other type of (bio) fuel (vegetable or animal oils, pure or diluted, domestic fuel...) is strictly prohibited (risk of damage to the engine and fuel system).

 The only Diesel additives authorised for use are those that meet the B715000 standard.

FUEL CUT-OFF

In a serious collision, a mechanism automatically prevents fuel from reaching the engine.



The flashing of this warning lamp is accompanied by a message in the screen.

Check that there is no odour or leakage of fuel outside the vehicle and re-establish the fuel supply:

- switch off the ignition (STOP position),
- remove the key,
- put the key back in the ignition,
- switch on the ignition and start.

DIESEL PRIMING PUMP

If you run out of fuel, it is necessary to prime the fuel circuit.

Other HDi engines

- Fill the fuel tank with at least five litres of Diesel.
- Squeeze and release the manual priming pump, under the bonnet, under the protective cover.
- Operate the starter until the engine starts.

BlueHDi engine

- Fill the fuel tank with at least five litres of Diesel.
- Switch on the ignition (without starting the engine).
- Wait around 6 seconds and switch off the ignition.
- Repeat the operation 10 times.
- Operate the starter to run the engine.

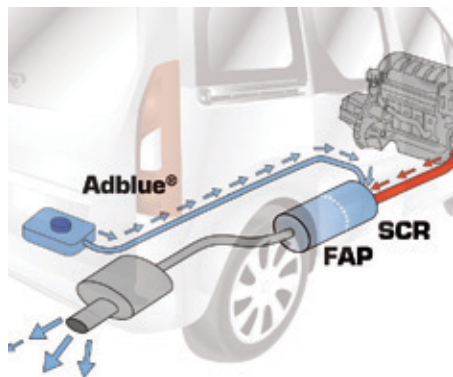

BLUEHDI AND ADBLUE®

SCR technology

The aim of BlueHDI is to reduce the emissions of NOx (nitrous oxides) in the air by up to 90%, using a system that converts NOx into water vapour and nitrogen in a dedicated catalytic converter: SCR (Selective Catalytic Reduction).

This objective meets the "Euro 6" emissions standard adopted by the European Union aimed at limiting the emissions of pollutants from internal combustion engines.

The SCR technology used on BlueHDI engines involves the injection of AdBlue® into the exhaust system.

AdBlue® is the brand name of the solution needed for operation of the SCR system.



BlueHDI vehicles have a specific AdBlue® additive tank with a **capacity of 17 litres**.

It has an exterior filler with a **blue filler cap**, located to the left of the Diesel fuel filler cap.

Filling of the AdBlue® tank can be done using 5 or 10 litre containers, 1.89 litre bottles, or when at a fuel filling station equipped with a special AdBlue® delivery pump for light vehicles.

I This operation can also be carried out by a PEUGEOT dealer or a qualified workshop.

Please note that the high delivery pumps at some filling stations, intended only for lorries and coaches, are not suitable for cars or light commercial vehicles.

Never use these pumps.



Filling the AdBlue® tank

For light vehicles, 5 or 10 litre containers and 1.89 litre (1/2 US gallon) bottles are available from PEUGEOT dealers, until they are equipped with AdBlue® delivery pumps.

If you want to fill the AdBlue® tank yourself, ensure that you have a suitable filler pipe, which may or may not be supplied with the additive container.

Good practice

While the quantity of AdBlue® in the additive tank is sufficient, no information is displayed.

On the other hand, once the fluid level drops to the quantity needed for a range of 1 500 miles (2 400 km) driving, you are warned by different temporary signals (warning lamp, message, audible signal).

As more miles are covered, these signals intensify and the message becomes permanent.

When the AdBlue® tank is empty, restarting becomes impossible.

It is strongly recommended that you do not wait for the successive alerts before topping-up the AdBlue® additive, but do this as soon as possible.



Range indicators

Rules on the display of alerts

Different levels of alert are triggered according to the remaining driving range threshold

You will be informed as each mileage threshold is reached and the alerts will change from temporary to permanent.

- The 1st is triggered at a remaining driving range of 1 500 miles (2 400 km).
- The 2nd is triggered at a remaining driving range of 350 miles (600 km).
- Up to 0 miles, at which point it will be impossible to restart the engine after a stop.



 For more information on the displays and warning lamps, refer to chapter 3, "Instruments and controls" section.

Driving range



Press this button to display the information.

With the touch screen:

-  - select the "Driving assistance" menu,
-  - select "Diagnostic",
- CHECK** - select CHECK.

If the range is greater than 3 100 miles (5 000 km), a range value is not given.

Range greater than 1 500 miles (2 400 km)

No information displayed.

Remaining range less than 1 500 miles (2 400 km) and greater than 350 miles (600 km)



Once the 1 500 miles (2 400 km) threshold is reached, the UREA warning lamp comes on temporarily and the remaining range message is displayed.

The alert is repeated every 200 miles (300 km) until the next threshold is reached.

Every time the ignition is switched on, the alert is given, together with an audible signal.

Remaining range less than 350 miles (600 km) and more than 0 miles



Once the 350 miles (600 km) threshold is reached, the UREA warning lamp flashes and the Service warning lamp comes on, accompanied by a message on the remaining driving range.

The alert is repeated every 30 seconds with an update of the remaining driving range in steps of 30 miles (50 km) travelled.

Every time the ignition is switched on, the alert is given together with an audible signal.

At 0 miles the system installed in the vehicle to meet the emissions standard will prevent engine starting.

Avoid waiting until the remaining range is 0 miles!

The alert is repeated when driving until the AdBlue® tank has been topped-up with sufficient additive.

Unless the additive in the special additive tank is topped-up, you risk immobilisation of the vehicle.

Starting prevented, breakdown related to a lack of AdBlue® in the special tank

The 0 fluid level has been reached.

Your vehicle's exhaust emissions no longer meet the "Euro 6" standard and the engine will not start.

To be able to **restart** the vehicle, you must add at least **4 litres** of AdBlue®.

- Pour the additive into the tank (by the filler with the blue cap).
- Switch on the ignition without starting.
- Wait 10 seconds before starting the engine.

 Or go to a PEUGEOT dealer or a qualified workshop.

 Following this, make a further fill to the special additive tank, the capacity of which is **17 litres**.

Fault with the SCR system

Detection



The UREA, Service and diagnostic warning lamps comes on.

Every time the ignition is switched on, the emissions fault is confirmed by an audible signal and a message.

If it is a temporary fault, the alert disappears as soon as the exhaust emissions return to the levels required by the standard.

 On the other hand, if the warning lamps are still on after 30 miles (50 km) of driving, the fault is confirmed.

An engine start prevention system will be activated automatically after 650 miles (1 100 km) travelled following this confirmation.

Go to a PEUGEOT dealer or a qualified workshop.

AdBlue®

Fault confirmed

In addition to the previous signals, the UREA warning lamp flashes and the remaining range allowed will be displayed in miles (kilometres).

The alert will be repeated every 30 seconds with an update of the driving range in steps of 30 miles (50 km).

Go to a PEUGEOT dealer or a qualified workshop as soon as possible.

You risk not being able to start the engine.

Starting prevented, having covered the 650 miles (1 100 km)



At each attempt at starting, the alert is activated and the message "Emissions fault: Starting prevented" is displayed.

Refilling / Topping-up the AdBlue®

Precautions to take

Use only AdBlue® that meets the ISO 22241 standard.

The AdBlue® fluid is an urea-based solution.

This fluid is non-flammable, colourless and odourless.

To be kept in a cool area.



Containers (5 or 10 litres) and bottles (1.89 litres) of AdBlue®

Please check the use-by date.

Read the instructions on the label.

Ensure that you have a suitable filler pipe, which may or may not be supplied with the container.

i To facilitate filling, an adaptor is available from PEUGEOT dealers.

! In the event of an overflow, wipe around the filler mouth using a damp cloth.

If any AdBlue® fluid is split or splashed on to you, wash immediately with cold water or wipe yourself with a clean damp cloth.

If the fluid has crystallised, clean it off using a sponge and hot water.



Filling

Ensure that the vehicle is parked on a flat and level surface.

Pour the contents of the container / bottle into the dedicated tank.

After filling the AdBlue® tank, observe the following procedure:

- Switch on the ignition without starting.
- Wait 10 seconds before starting the engine.

i Never dispose of empty AdBlue® containers and bottles in the household waste.

Place them in a special container provided this purpose or take them to your dealer.

i Keep AdBlue® out of the reach of children, in its original container.

Never transfer AdBlue® to another container: it would lose its purity.

Never dilute the fluid with water.

Never pour the fluid into the Diesel fuel tank.

Recommendations on storage

Never store containers or bottles of AdBlue® in your vehicle.

Freezing of the AdBlue®

AdBlue® freezes at about -11°C (12.2° F) and deteriorates above 25°C (77°F).

It is recommended that containers and bottles be stored in a cool area and protected from direct sunlight.

Under these conditions, the fluid can be kept for at least a year.

Additive that has been frozen can be used once it has thawed out in ambient air.

i The SCR system includes an AdBlue® tank heater that ensures operation of the vehicle in normal conditions.

In exceptional situations, such as when the vehicle is kept at temperatures below -15°C (5°F) for a long period, there may be an emission fault alert related to freezing of the AdBlue® additive.

Park the vehicle in an area at a more moderate temperature for a few hours until the AdBlue® becomes a fluid again.

The emissions warning lamp does not go off immediately, but does so after a few miles of driving.

Battery

BATTERY

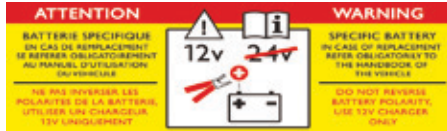

i The presence of this label indicates the use of a 12 V lead-acid battery with special technology and specification, for which the involvement of a PEUGEOT dealer or qualified workshop is required when replacing or disconnecting the battery. Failure to observe this recommendation may cause premature wear of the battery.

After refitting the battery, the Stop & Start system will only be active after several hours depending on the climatic conditions and the state of charge of the battery (up to about 8 hours).

The Stop & Start battery does not have to be disconnected for charging.

To charge the battery using a battery charger

- Disconnect the battery.
- Follow the instructions for use given by the battery charger manufacturer.
- Reconnect starting with the negative (-) terminal.
- Check that the terminals and connectors are clean. If they are covered with sulphate (white or greenish deposit), disconnect them and clean them.

To start the vehicle from another battery

- Connect the red cable to the positive (+) terminals of the two batteries.
- Connect one end of the green or black cable to the negative (-) terminal of the slave battery.
- Connect the other end of the green or black cable to an earth point on the broken down vehicle as far as possible from the battery.
- Operate the starter, let the engine run.
- Wait for the engine to return to idle, then disconnect the cables.

i It is advisable to disconnect the battery if the vehicle is not to be used for a period of more than one month.

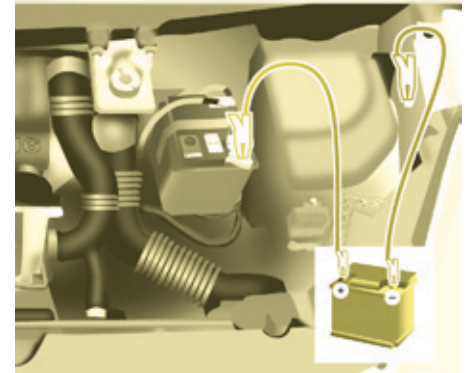

Before disconnecting the battery, you must wait for 2 minutes after switching off the ignition.

Never disconnect a terminal when the engine is running.

Never charge a battery without first disconnecting the terminals.

After every reconnection of the battery, switch on the ignition and wait 1 minute before starting to allow the electronic systems to be initialised. If problems remain after doing this, please contact a PEUGEOT dealer or a qualified workshop.

After changing bulbs, wait approximately 3 minutes before reconnecting the battery.

ECONOMY MODE

After the engine has stopped, with the key in the ignition position, certain functions (windscreen wiper, electric windows, courtesy lamps, audio equipment, etc.) can only be used for a cumulative duration of thirty minutes, to prevent discharging of the battery.

Once the thirty minutes have elapsed, the active functions are put on standby and the battery warning lamp flashes accompanied by a message in the screen.

To resume the use of these functions immediately, start the engine and let it run for a few minutes.

The time available will then be double the time for which the engine was left running. However, this time will always be between five and thirty minutes.

 A flat battery will prevent the engine from starting.

Changing a wheel

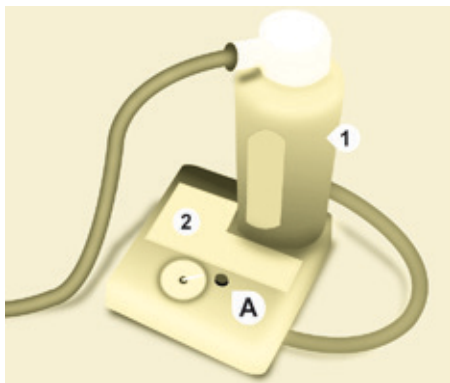

TEMPORARY PUNCTURE REPAIR KIT

The kit is located in one of the two storage compartments located under the front seats.

Vehicles supplied with a temporary puncture repair kit do not have a spare wheel or tooling (jack, wheelbrace, ...).

The temporary tyre repair kit consists of a compressor and a bottle (containing a sealant).

Using the kit

- Tick the deflated wheel on the speed limitation sticker then affix the sticker to the vehicle's steering wheel to remind you that a wheel is in temporary use.
- Clip the bottle **1** on the compressor **2**.
- Connect the bottle **1** to the valve of the tyre to be repaired.
- Take care to unwind the compressor pipe before connecting it to the bottle.
- Connect the power lead to one of the vehicle's 12V sockets.
- Switch on the compressor by pressing button **A** until the tyre pressure reaches 2.0 bars. If this pressure cannot be reached, the tyre cannot be repaired.
- Remove and store the compressor.
- Drive immediately, for a few miles (kilometres), at reduced speed, to fill the puncture.
- Adjust the pressure using the compressor in accordance with the recommendation for the vehicle and check that the leak is filled correctly (no further loss of pressure).
- Drive at reduced speed (50 mph [80 km/h]). The tyre must be examined and repaired by a specialist as soon as possible.

After use, the bottle can be stored in a plastic bag, supplied in the kit, to avoid staining your vehicle with traces of fluid.

! Warning: the sealant product is harmful if swallowed and causes irritation to the eyes.

Keep it out of reach of children.

After use, do not discard the bottle into the environment, take it to a PEUGEOT dealer or to an specialised waste disposal site.

Replacement bottles of sealant are available from PEUGEOT dealers.

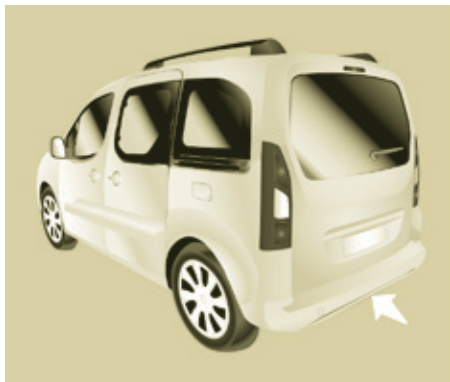

CHANGING A WHEEL

1. Parking the vehicle

- The occupants must get out of the vehicle and wait in a safe location.
- If possible, park the vehicle on level, stable and non-slippery ground.
- Apply the parking brake, switch off the ignition and engage first or reverse gear.

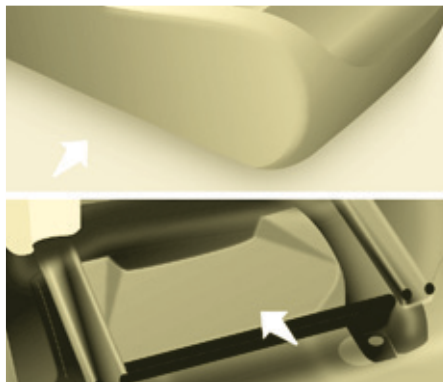
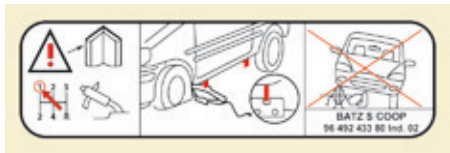

- Place a chock under the wheel diagonally opposite the one to be changed.

If the vehicle is fitted with a towbar, it is sometimes necessary to raise the vehicle slightly to make it easier to remove the spare wheel from its carrier.

On certain types of ground and/ or if considerable loads are being transported, call a PEUGEOT dealer or a qualified workshop.

The jack and tools are specific to your vehicle. Do not use them for other purposes.

2. Tools

The tools are stowed in a storage area closed by a flap under a front seat.

However, if the vehicle is not equipped with a spare wheel, the towing eye is located in the storage compartment



under the passenger footwell behind the driver's seat.

- If necessary, move the seat forward to access the storage compartment from the rear.
 - Remove the flap then take out the jack and the tool carrier.
 - Remove the tools needed from the carrier.
1. Jack.
 2. Wheelbrace.
 3. Chock.
 4. Spanner for the Zenith roof bars and rear lamps.
 5. Alloy wheel trim removal tool.
 6. Towing eye.

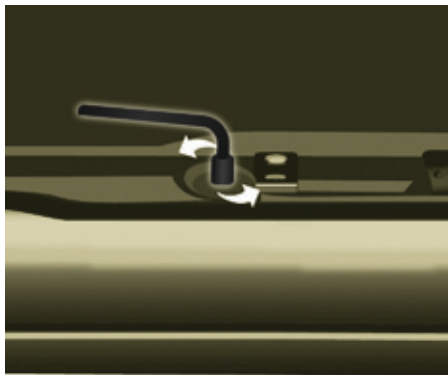

3. Spare wheel

- Open the rear doors to gain access to the spare wheel.
- Unscrew the bolt using the wheelbrace until the carrier is lowered fully.
- Detach the carrier from the hook and place the spare wheel near the wheel to be changed.



4. Removing the wheel with punctured tyre

- Remove the wheel trim.
- Loosen the wheel bolts and start unscrewing them.
- Position the foot of the jack on the ground and ensure that it is directly below the front or rear jacking point provided on the underbody, whichever is closest to the wheel to be changed.
- Extend the jack until its head comes into contact with the jacking point used; the vehicle's contact point **A** must be engaged with the head of the jack.
- Raise the vehicle until there is sufficient space between the wheel and the ground, so that the (not punctured) spare wheel can be easily fitted.
- Resume and complete the unscrewing of the wheel bolts.
- Remove the bolts and remove the wheel.

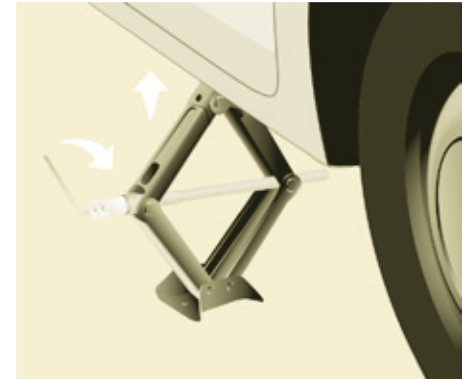
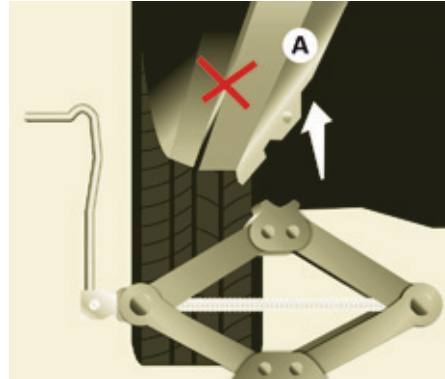

Ensure that the jack is stable, the foot of the jack must be in contact with the ground, and directly below the jacking point used.

If the ground is slippery or loose, the jack may slip or drop - Risk of injury!

Ensure that the jack is positioned only at one of the jacking points under the vehicle, making sure that the vehicle's contact surface is centred on the head of the jack.

Otherwise there is a risk of damage to the vehicle and/or of the jack dropping - Risk of injury!

Do not extend the jack until you have started unscrewing the bolts on the wheel to be changed and have placed the chock under the wheel diagonally opposite.

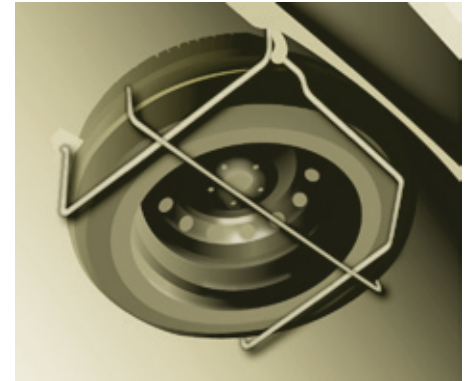
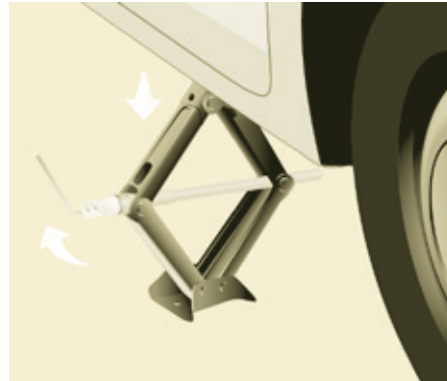

5. Fitting the spare wheel

! When using the non-uniform spare wheel, do not exceed a speed of 50 mph (80 km/h).

The spare wheel is not designed to be used over long distances. Have the tightening of the bolts and the tyre pressure checked by a PEUGEOT dealer or a qualified workshop as soon as possible.

Have the original wheel repaired and refitted by a PEUGEOT dealer or a qualified workshop as soon as possible.

- Position the wheel on the hub and start tightening the bolts by hand.
- Carry out an initial tightening of the bolts using the wheelbrace.

- Lower the vehicle completely by folding the jack, then remove the jack.
- Tighten the bolts again using the wheelbrace, tighten them fully without forcing them.
- Place the wheel to be repaired in the carrier.

- Secure the carrier on the hook then raise the carrier by tightening the bolt with the wheelbrace.
- Fully tighten the bolt, then check that the wheel is held flat against the floor.

If this is not the case, repeat the operation.

! Never go underneath a vehicle that is supported only by a jack (use a stand).

Never use a power driver in place of the wheelbrace.

6. Refitting the repaired wheel

The wheel is refitted as described in step 5, not forgetting to refit the wheel trim.

+ Refer to the "Identification markings" section of chapter 9 to locate the tyre label.

+ Refer to the "Instruments and controls" section of chapter 3, "Tyre under-inflation detection" part, for recommendations after changing a wheel fitted with a tyre under-inflation detection sensor.

FITTING THE WHEEL TRIM

The tyre valve must be centred in the wheel trim cut-out.

This position is essential for fitting the wheel trim correctly on the steel wheel. (If the valve is not correctly aligned with the cut-out, the anti-rotation system will be in contact with the heads of the wheel bolts and risks being damaged if the user persists in fitting the wheel trim in this incorrect position).



- Ensure that the outer edge of the wheel trim is not deformed or pushed into the wheel:
 - **Correct position** for the edge of the wheel trim.
 - **Incorrect position** for the edge of the wheel trim.



- Ensure that all of the clips are engaged except the last one (opposite the valve hole).

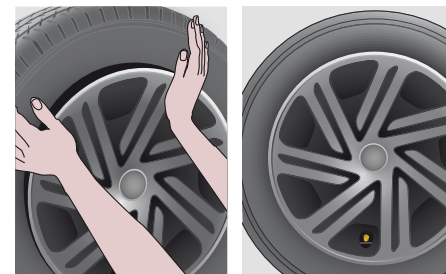

- Strike the wheel trim with the palm of your hand, opposite the valve in the area of the last fixing clip (always in the direction of clipping).

Changing a wheel

- 1 Check the position of the tyre valve relative to the ring of the wheel trim.

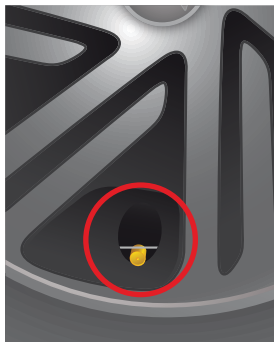

Valve **not positioned correctly**: below the ring.



Deformation of the edge of the wheel trim at the valve, because it is fitted incorrectly.



Valve **positioned correctly**: below the ring.

- 1 Observe the wheel trim fitting procedure, so as to avoid breaking the fixing clip and deformation at the edge of the wheel trim.



REMOVABLE SNOW SCREEN (BLANKING COVER)

According to country, the removable snow screen is installed on the lower part of the front bumper to prevent the accumulation of snow at the radiator cooling fan.

i Do not forget to remove the snow screen when the exterior temperature is higher than 10°C (no risk of snowfall) and when towing.

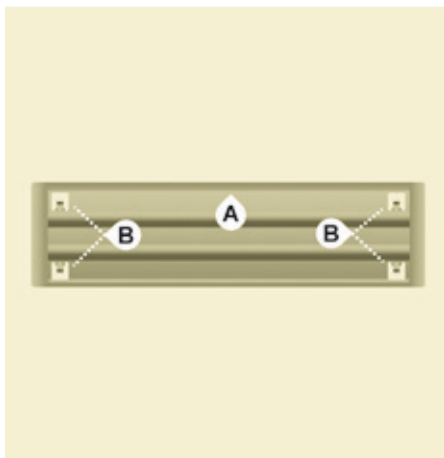

Fitting

- Offer up the snow screen facing its centring pin **A** on the front bumper.
- Put it in place by pressing at each clip **B** located in the four corners.

Removal

- Pass a screwdriver into the hole located near each of the clips.
- Use the screwdriver as a lever to unclip the four clips **B** in turn.

Snow chains

SNOW CHAINS

In wintry conditions, snow chains improve traction as well as the behaviour of the vehicle when braking.



i The snow chains must be fitted only to the driving wheels. They must never be fitted to "space-saver" type spare wheels.

Use only the chains designed to be fitted to the type of wheel fitted to your vehicle:

Original tyre size	Maximum link size.
195/65 R15	9 mm
195/70 R15	
205/65 R15	
215/55 R16	
215/50 R17	

For more information on snow chains, contact a PEUGEOT dealer or a qualified workshop.

i Take account of the legislation in force in your country on the use of snow chains and the maximum running speed authorised.

Advice on installation

- ☞ If you have to fit the chains during a journey, stop the vehicle on a flat surface on the side of the road.
- ☞ Apply the parking brake and position any wheel chocks to prevent movement of your vehicle.
- ☞ Fit the chains following the instructions provided by the manufacturer.
- ☞ Move off gently and drive for a few moments, without exceeding 30 mph (50 km/h).
- ☞ Stop your vehicle and check that the snow chains are correctly tightened.

i It is recommended that before you leave, you practise fitting the snow chains on a level and dry surface.

! Avoid driving with chains on roads that have been cleared of snow, to avoid damaging your vehicle's tyres and the road surface. If your vehicle is fitted with alloy wheels, check that no part of the chain or its fixings is in contact with the wheel rim.

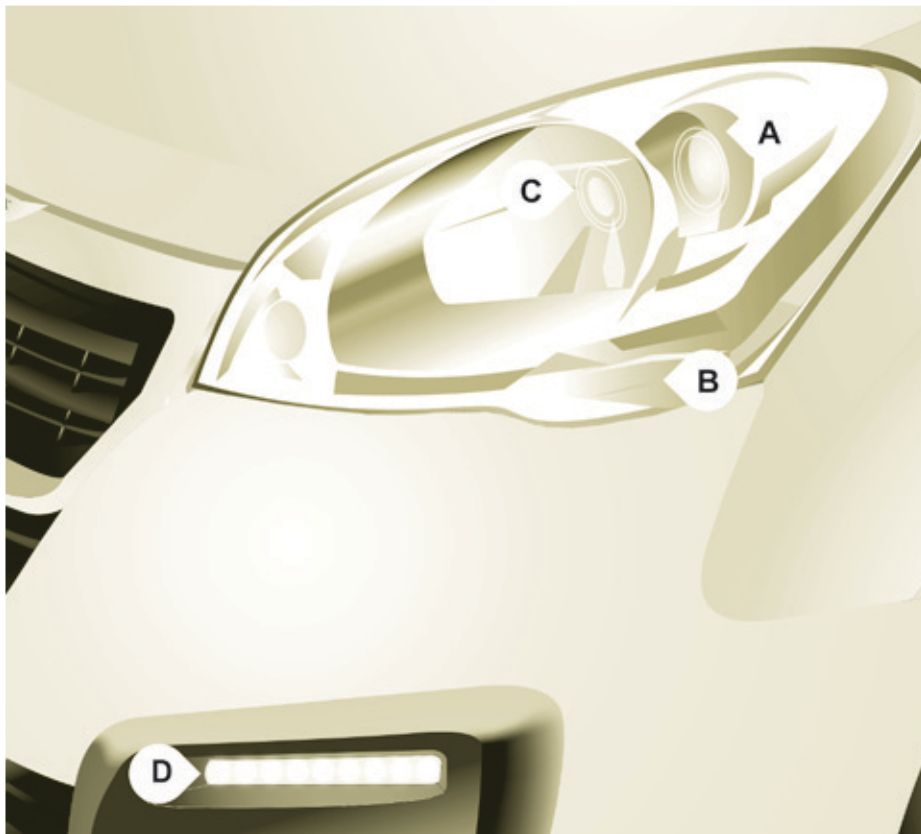

CHANGING A BULB

Types of bulb

Various types of bulb are fitted to your vehicle.

To remove them:

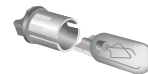

Type A

All glass bulb: pull gently as it is fitted by pressure.



Type B

Bayonet bulb: press on the bulb then turn it anticlockwise.



Type C

Halogen bulb: release the retaining spring from its housing.



Type D

Light-emitting diode (LED): for replacement of the daytime running lamps, contact a PEUGEOT dealer or a qualified workshop.

Changing a bulb

Open the bonnet. To access the bulbs, reach behind the headlamp unit.

Carry out the operations in reverse order to refit each bulb and check that the bonnet is closed securely.

! Halogen bulbs must be changed with the headlamp off. Wait a few minutes (risk of serious burns).

Do not touch the bulb directly with your fingers, use lint-free cloths.

It is normal for condensation to form inside the headlamps. Regular use of the vehicle eliminates this misting.

The bulbs must be changed with the ignition off or with the battery disconnected. Wait approximately 3 minutes after changing the bulb before reconnecting the battery.

Check that the lamps operate correctly after each operation.

High pressure washing

! When using this type of washing on stubborn dirt, do not persist on the headlamps, the lamps and their edges to avoid damaging their coating and seals.

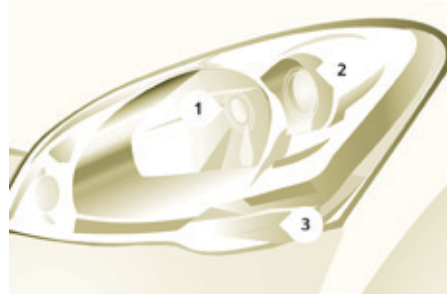

Front lamps

1. Dipped / Main beam headlamps

Type C, H4 - 55W

- Remove the centre cover by pulling the flexible rubber tab.
- Disconnect the electrical connector.
- Release the retaining tab.
- Change the bulb taking care to align the metal part with the grooves on the lamp.
- Reposition the retaining tab.
- Ensure that the cover is refitted correctly all round to assure correct sealing.

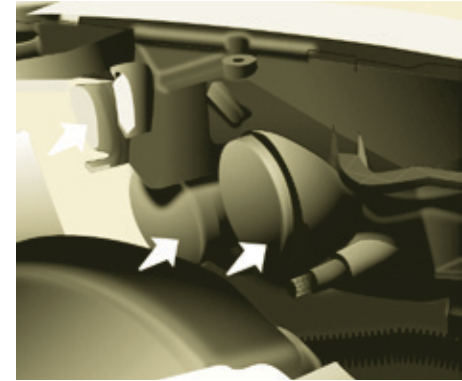

2. Sidelamps

Type A, W5W - 5W

- Remove the cover by pulling the flexible rubber tab.
- Remove the bulb holder fitted by pressure by pulling the connector.
- Change the bulb.
- Ensure that the cover is refitted correctly all round to assure correct sealing.

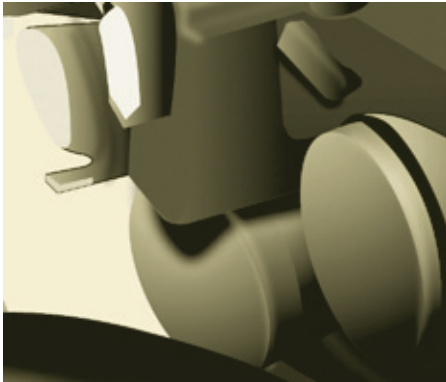

3. Direction indicators

Type B, PY21W - 21W (amber)

- Remove the cover by pulling the flexible rubber tab.
- Turn the bulb holder a quarter turn anticlockwise.
- Remove the bulb by pressing it lightly while turning it anticlockwise.
- Change the bulb.
- Ensure that the cover is refitted correctly all round to assure correct sealing.



4. Front foglamps

Type C, H1 - 55W

- Remove the three clips and the screw securing the wheel arch liner, located below the bumper.
- Move the wheel arch liner upwards.
- Disconnect the bulb holder connector by pressing the tab at the top.

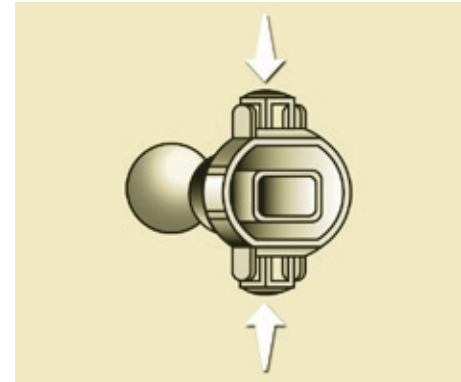

- Remove the bulb holder by squeezing the two clips (at top and bottom) using a finger and thumb.
- Replace the module (bulb holder and bulb).
- Carry out the operations in reverse order to fit the module and refit the wheel arch liner.

Changing a bulb

184



Side repeater

Type A, WY5W - 5W (amber)

- Push the repeater towards the rear and disengage it by pulling the front.
- Contact a PEUGEOT dealer to obtain a new repeater which is a sealed component.
- To refit, engage the repeater towards the rear and bring it towards the front.



Front / Rear

Courtesy lamps

Type A, 12V5W - 5W

- Unclip the lens by sliding a screwdriver in the slots on each side of the courtesy lamp.
- Pull the bulb out and change it.
- Clip the lens in its housing and ensure that it is secured correctly.

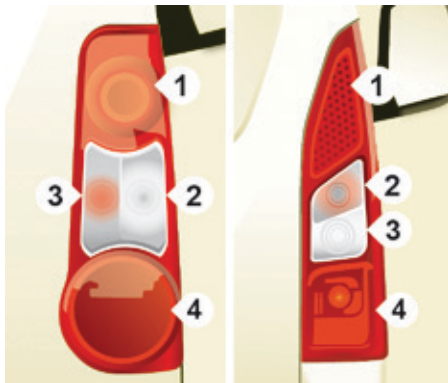

Rear lamps

For more information on bulbs, refer to the "Types of bulb".

1. Brake lamps / sidelamps

Type B, P21/5W - 21/5W

2. Direction indicators

Type B, PY21W - 21W (amber)

3. Reversing lamps

Type B, P21W - 21W

4. Foglamps

Type B, P21W - 21W

High pressure jet washing

i When using this type of washing on stubborn dirt, do not persist on the headlamps, the other lamps and their edges to avoid damaging their coating and seals.

This procedure requires the use of the spanner supplied with the tools for changing a wheel.

+ Chapter 9, "Changing a wheel" section.

- Identify the failed bulb, then open the rear doors to 180°.

+ Chapter 3, "Access" section.

- Remove the two fixing bolts using the spanner provided.
- Pull the lamp unit from the outside.
- Holding the lamp, disconnect the electrical connector.

- Move aside the 4 tabs then extract the bulb holder.
- Remove the faulty bulb by pressing it lightly while turning it anticlockwise.
- Change the bulb.

When removing the lamp unit:

- with tailgate, pull the lamp unit towards the centre of the vehicle,
- with hinged doors, pull the lamp unit towards you.

i When refitting, take care to reposition the tabs and the wiring correctly to avoid trapping the wiring.

After changing the rear direction indicator bulb, the reinitialisation time is above 2 minutes.

Changing a bulb



Number plate lamps

Type A, W5W - 5W

With tailgate

- Disengage the plastic lens using a screwdriver.
- Change the bulb.
- Replace the plastic lens and press on it.

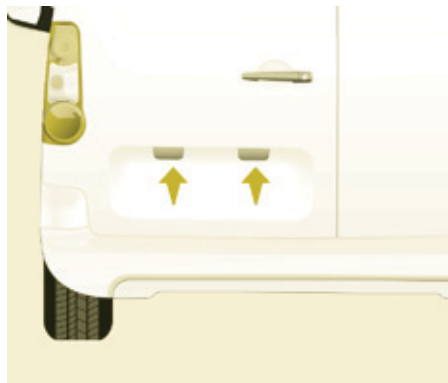

With hinged doors

- Unclip the interior trim.
- Disconnect the connector by moving aside its tab.
- Turn the bulb holder a quarter turn anticlockwise.
- Change the bulb.
- Put the bulb holder back in place and reconnect the connector.
- Put the trim back in place.



Third brake lamp

Type A, W16W - 16W

- Unscrew the two nuts.
- Push the pins.
- If necessary, disconnect the connector to remove the lamp.
- Change the bulb.



CHANGING A FUSE

The fuseboxes are located:

- in the lower dashboard on the left-hand side (behind the cover),
- under the bonnet (near the battery).

The information given concerns only those fuses which can be changed by the user using the tweezers, located behind the dashboard storage compartment on the right-hand side. For any other work, visit a PEUGEOT dealer or a qualified workshop.

i Motor trade technicians: for complete information on the fuses and relays, refer to the "Repair Manual" diagrams via the dealer network.

PEUGEOT will not accept responsibility for the cost incurred in repairing your vehicle or for rectifying the malfunctions resulting from the installation of accessories not supplied and not recommended by the PEUGEOT network and not installed in accordance with its instructions, in particular when the combined consumption of all of the additional equipment connected exceeds 10 milliamperes.

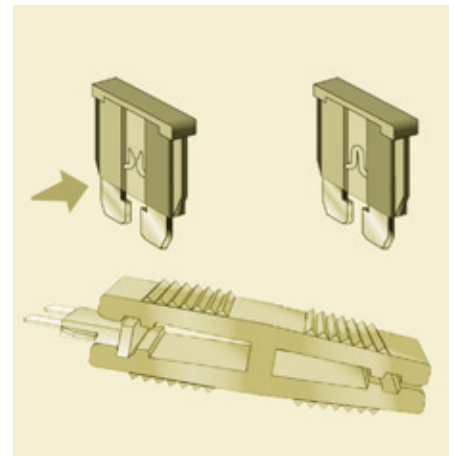

Removing and fitting a fuse

Before replacing a fuse, the cause of the incident must be identified and rectified.

- Use the tweezers.

Always replace a failed fuse with a fuse of the same rating.

Changing a fuse

Dashboard fuses

Tilt the cover to gain access to the fuses.

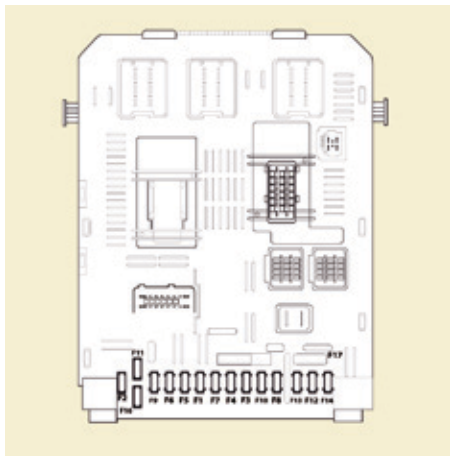

Fuses F	Amperes A	Allocation
1	15	Rear wiper
2	-	Not used
3	5	Airbag
4	10	Air conditioning, diagnostic socket, mirror control, headlamp beam
5	30	Electric windows
6	30	Locks
7	5	Rear courtesy lamp, front map reading lamp, roof console
8	20	Audio equipment, screen, tyre under-inflation detection, alarm and siren
9	30	Front and rear 12V socket
10	15	Central column
11	15	Low current ignition switch
12	15	Rain and sunshine sensor, airbag
13	5	Instrument panel
14	15	Parking sensors, digital air conditioning controls, hands-free phone kit
15	30	Locks
16	-	Not used
17	40	Rear screen/mirrors demist/defrost

Passenger compartment fuses

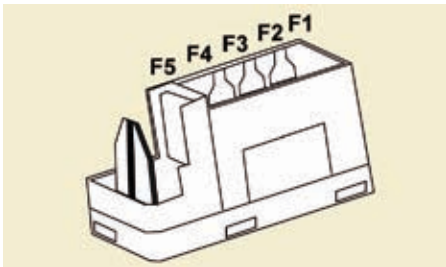

Fuses F	Amperes A	Allocation
1	-	Not used
2	20	Heated seats
3	-	Not used
4	15	Folding mirrors relay
5	15	Refrigeration equipment socket relay

Changing a fuse

Fuses under the bonnet

After opening the bonnet, unclip and tilt the corresponding box to gain access to the fuses.

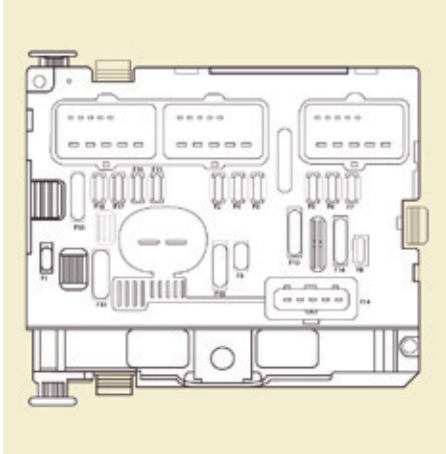

Fuses F	Amperes A	Allocation
1	20	Engine management
2	15	Horn
3	10	Front and rear wash-wipe pump
4	-	Not used
5	15	Engine components
6	10	Steering wheel angle sensor, DSC
7	10	Brake switch, clutch switch
8	25	Starter motor
9	10	Headlamp beam motor, fleet management unit
10	30	Engine components
11	40	Not used
12	30	Wipers
13	40	Built-in systems interface
14	30	Pump
15	10	Right-hand main beam headlamp
16	10	Left-hand main beam headlamp
17	15	Right-hand dipped beam headlamp
18	15	Left-hand dipped beam headlamp



CHANGING A WIPER BLADE

Placing the windscreen wiper blades in the special position

- Within a minute after switching off the ignition, press the wiper stalk downwards to position the wiper blades along the windscreen pillars (special position).



Changing a front wiper blade

- Lift the wiper arm.
- Unclip the blade and remove it.
- Fit the new blade.
- Push back the wiper arm.

To return the windscreen wipers to their normal position, switch on the ignition and operate the wiper stalk.



Changing the rear wiper blade

- Lift the wiper arm, then unclip the blade and remove it.
- Fit the new blade and push back the wiper arm.

Having your vehicle towed

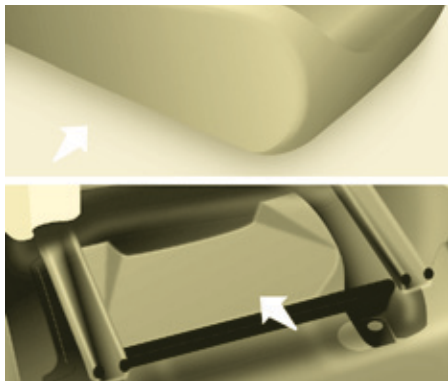

BEING TOWED

This procedure involves the use of the towing eye supplied with the tools for changing a wheel.

 Section 8, "Changing a wheel".

Without lifting (4 wheels on the road)

You should always use a towing arm.



From the front

- Unclip the cover by pressing the bottom part.
- Fully screw in the removable towing eye.

From the rear

- Unclip the cover using a coin or the flat part of the towing eye,
- Fully screw in the removable towing eye.

Lifting (only 2 wheels on the road)

It is preferable to raise the vehicle using professional lifting equipment.



 When towing with the engine switched off, there is no braking or steering assistance.

Vehicles fitted with a manual gearbox (Diesel version)

In the case of vehicles fitted with a manual gearbox, the gear lever must be in neutral, failure to observe this special condition may result in damage to transmission and braking components and the absence of braking assistance when the engine is started again.



Dimensions

DIMENSIONS (MM)

L	Overall length	4380	
H	Overall height	1801-1862	
A	Wheelbase	2728	
B	Front overhang	925	
C	Rear overhang	727	
D	Width over panels:	without mirrors	1810
		with mirrors	2112
E	Width of front tracks	1505-1507	
F	Width of rear tracks	1554-1556	
-	Length of the loading surface to the seat	Row 2	990
		Row 2, seat fully folded	1343
		With front passenger seat folded	3000

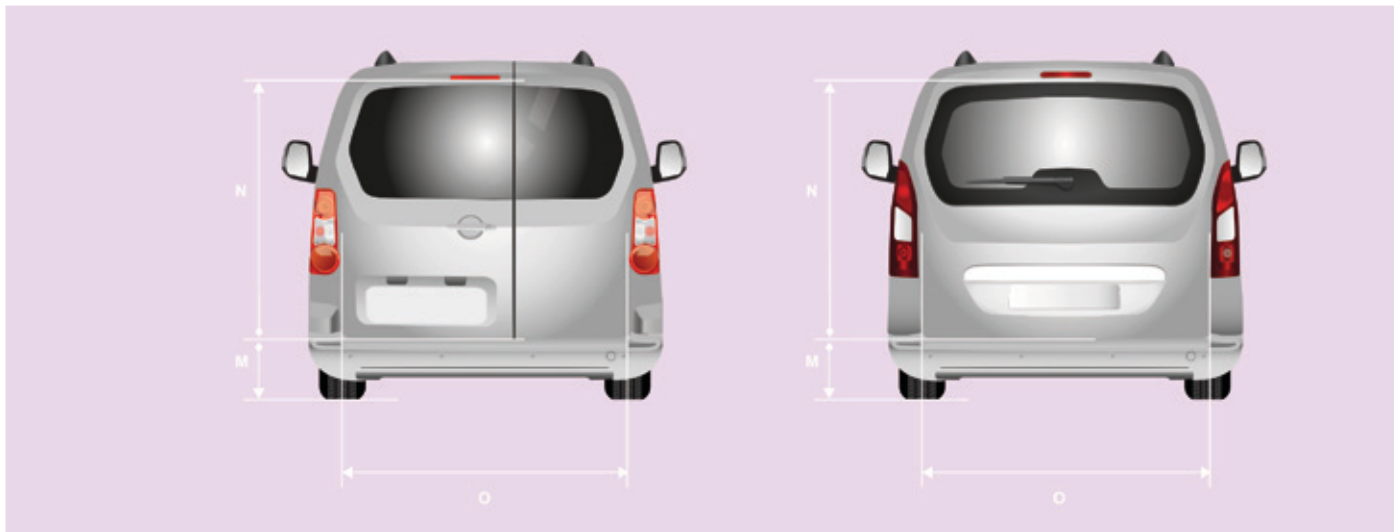

		Rear doors (mm)		
M	Max sill height with 205/65 R15 tyres and tailgate trim	582		
		Hinged doors		Tailgate
		Small	Large	
N	Aperture height (under panel)	1118		
O	Aperture width	495	543	1582

Dimensions

196



		Sliding side doors (mm)
P	Aperture height	1009
Q	Aperture width	640
-	Height under raised tailgate	1892

ENGINE CHARACTERISTICS

The engine characteristics (capacity, maximum power, maximum power speed, fuel, CO₂ emissions...) for your vehicle are given in the registration certificate.

These characteristics correspond to the values type-approved on a test bed, under conditions defined in European legislation (Directive 1999/99/EC).

For more information, refer to the manufacturer's website or sales brochure for the model. Contact a PEUGEOT dealer or a qualified workshop.

WEIGHTS AND TOWED LOADS

These values, expressed in kg, can be found on the manufacturer's VIN plate or label.

The maximum weights and towed loads for your vehicle can be found on the vehicle's registration certificate.



The location of the manufacturer's plate is given in chapter 9, "Identification markings" section.

In each country, it is imperative that the maximum towed loads authorised by local legislation are complied with. To find out your vehicle's towing capacities and its gross train weight, consult a PEUGEOT dealer.

The kerb weight is equal to the weight without load + driver (75 kg) + fuel tank filled to 90%.

The GTW and towed load values indicated are valid up to a maximum altitude of 1000 metres. The value of the towed load mentioned must be reduced by 10 % for each additional 1000 metres.

With load transfer, the braked trailer weight can be increased, on condition that the equivalent of this load is removed from the vehicle so that the GTW is not exceeded.

The recommended nose weight is the downward force on the towball (removable with or without tools).

GVW: gross vehicle weight, the maximum authorised weight.

GTW: gross train weight, the maximum weight for vehicle plus trailer.



High ambient temperatures may result in a reduction in the performance of the vehicle in order to protect the engine. When the ambient temperature is higher than 37 °C, limit the towed weight.



Towing with a lightly loaded vehicle can adversely affect road holding.

Towing a trailer increases braking distances.

When towing, the maximum permitted speed is reduced (comply with the legislation in force in the country).

Weights

Petrol Engines / Weights

5-seat

Engine	Gearbox	Engine oil capacity with filter replacement (litres)	Unbraked trailer (kg)	Recommended nose weight (kg)
1.6 110 hp	5-speed manual	3.25	750	55
1.6 VTi 100 hp	5-speed manual	4.25	600	70
1.6 VTi 120 hp	5-speed manual	4.25	690	70
1.6 VTi 120 hp Euro 6	5-speed manual	4.25	600	70
1.2 PureTech S&S 110 hp Euro 6	5-speed manual	3.45	600	70

7-seat

Engine	Gearbox	Engine oil capacity with filter replacement (litres)	Unbraked trailer (kg)	Recommended nose weight (kg)
1.6 110 hp	5-speed manual	3.25	750	70

Diesel Engines / Weights

5-seat

Engine	Gearbox	Engine oil capacity with filter replacement (litres)	Unbraked trailer (kg)	Recommended nose weight (kg)
1.6 HDi 75 hp	5-speed manual	-	600	70
1.6 HDi 75 hp FAP	5-speed manual	-	715	70
BlueHDi 75 hp Euro 6	5-speed manual	-	720	70
1.6 HDi 90 hp	5-speed manual	3.75	735	70
1.6 HDi 92 hp FAP	5-speed manual	3.75	715	70
1.6 e-HDi 92 hp FAP	5-speed manual	3.75	690	70
1.6 BlueHDi 100 hp Euro 6	5-speed manual	3.75	600	70
1.6 BlueHDi 100 hp S&S	5-speed manual	3.75	600	70
	6-speed electronic		600	70
1.6 HDi 115 hp FAP	5-speed manual	3.75	735	70
1.6 BlueHDi 120 hp Euro 6	6-speed manual	3.75	600	70

FAP: particle filter.

e-HDi: model equipped with Stop & Start.

Weights

200

7-seat

Engine	Gearbox	Engine oil capacity with filter replacement (litres)	Unbraked trailer (kg)	Recommended nose weight (kg)
1.6 HDi 92 hp FAP	5-speed manual	3.75	750	70
1.6 BlueHDi 100 hp Euro 6	5-speed manual	3.75	600	70
1.6 BlueHDi 100 hp Euro 6 S&S	5-speed manual	3.75	600	70
1.6 HDi 115 hp FAP	5-speed manual	3.75	750	70
1.6 BlueHDi 120 hp Euro 6	6-speed manual	3.75	600	70

FAP: particle filter.

e-HDi: model equipped with Stop & Start.

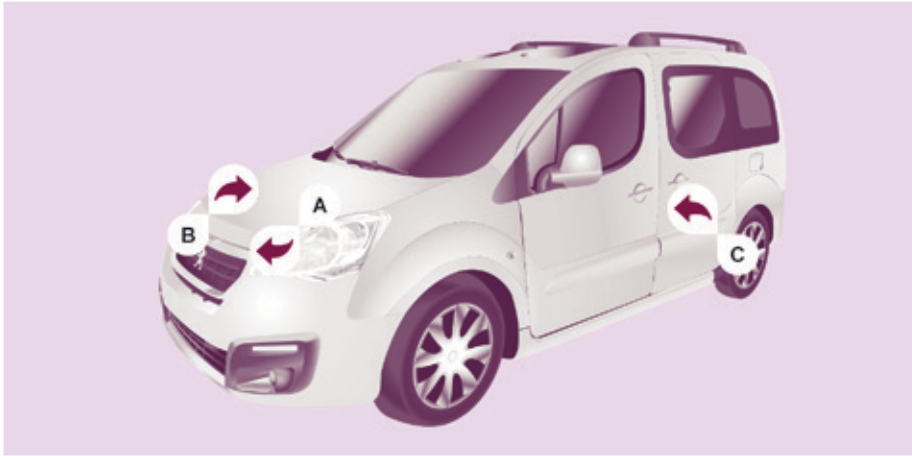

IDENTIFICATION MARKINGS

A. Manufacturer's plate.

B. Serial number.

This is engraved on the front right wheelarch.

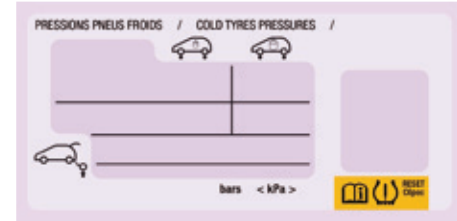

C. Tyres and paint colour code.

The label **C**, on the front door gives:

- the wheel and tyre sizes,
- the tyre pressures, laden and unladen,
- the tyre pressure of the spare wheel,
- the paint colour code.

The tyre pressures should be checked when cold, at least once a month.

i If your vehicle is fitted with the system, refer to the "Under-inflation detection" section in Chapter 3.



7-inch touch screen

GPS satellite navigation - Multimedia audio - Bluetooth® telephone



	Contents
First steps	204
Steering mounted controls	206
Menus	207
Navigation	208
Navigation - Guidance	216
Traffic	220
Radio Media	222
Radio	228
DAB (Digital Audio Broadcasting) radio	230
Media	232
Settings	234
Connected services	242
MirrorLink™	242
CarPlay®	246
Telephone	248
Frequently asked questions	256

i The system is protected in such a way that it will only operate in your vehicle.

! As a safety measure, the driver should only carry out operations which require prolonged attention while the vehicle is stationary. The display of an energy economy mode message signals that electrical systems operating are going into standby. Refer to the energy economy mode section.

First steps

Use the buttons above the touch screen for access to the menu carousel, then press the virtual buttons in the touch screen.
Each menu is displayed in one or two pages (primary page and secondary page).



i In very hot conditions, the system may go into stand-by (screen and sound completely off) for a minimum period of 5 minutes.

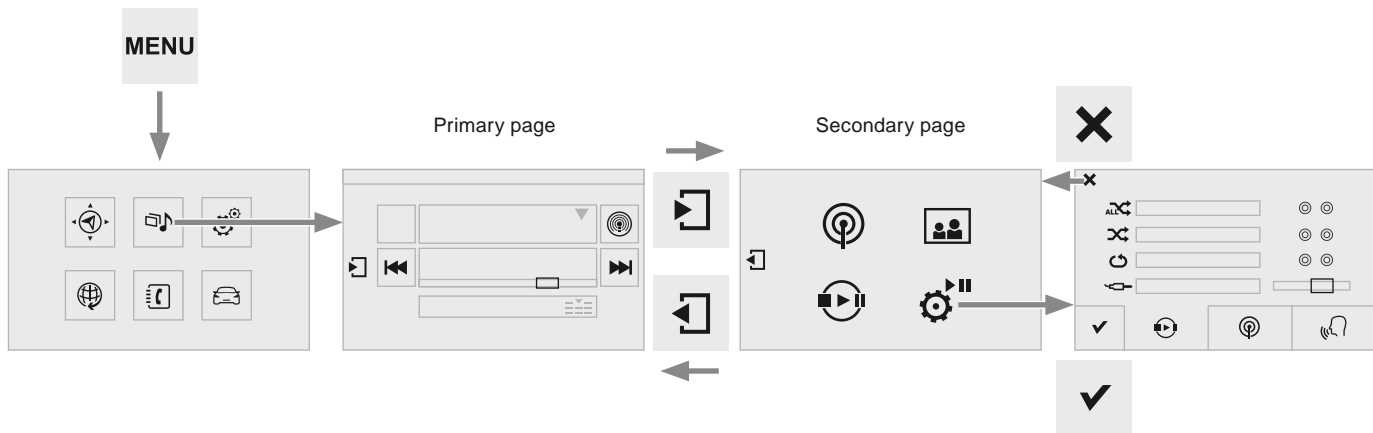

Short-cuts: using the touch buttons in the upper band of the touch screen, it is possible to go directly to the selection of the audio source or the list of stations (or titles, depending on the source).

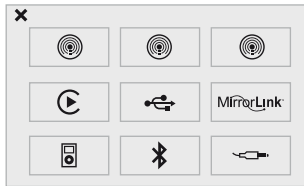

Selecting the audio source (depending on version):

- "FM" / "DAB" / "AM" stations.
- "USB" memory stick.
- Smartphone via MirrorLink™ or CarPlay®.
- Telephone connected by Bluetooth® and Bluetooth® audio streaming.
- Media player connected to the auxiliary socket (jack, cable not supplied).

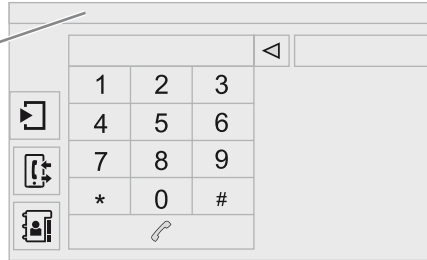

MENU

Press **Menu** to display the menu carousel.

Volume adjustment (each source is independent, including traffic announcements (TA) and navigation instructions).



Increase volume.



Reduce volume.

Mute the sound by pressing simultaneously on the volume increase and reduce buttons. Unmute the sound by pressing one of the two volume buttons.

i In very high temperatures, the volume may be limited to protect the system. The return to normal takes place when the temperature in the passenger compartment drops.

i The screen is of the "resistive" type, it is necessary to press firmly, particularly for "flick" gestures (scrolling through a list, moving the map...). A simple wipe will not be enough. Pressing with more than one finger is not recognised. The screen can be used when wearing gloves. This technology allows use at all temperatures.

! To clean the screen, use a soft non-abrasive cloth (spectacles cloth) without any additional product. Do not use pointed objects on the screen. Do not touch the screen with wet hands.

* Depending on equipment.

Steering mounted controls



Radio: select the previous/next preset station.
Media: select a genre / artist / folder from the list.
Select the previous/next entry in a menu.



Radio: automatic search for a higher frequency.
Media: Select next track.
Media, press and hold: fast forward. Jump in the list.



Change the audio source.
Confirm a selection.
Call/end call on the telephone.
Press for more than 2 seconds: access to the telephone menu.



Radio: automatic search for a lower frequency.
Media: select previous track.
Media, press and hold: fast back. Jump in the list.



Increase volume.



Decrease volume.



Mute: cut the sound by pressing the volume increase and decrease buttons simultaneously.
Restore the sound by pressing one of the two volume buttons.

Menus



Navigation

(Depending on equipment)



Enter navigation settings and choose a destination.



Connected services

(Depending on equipment)

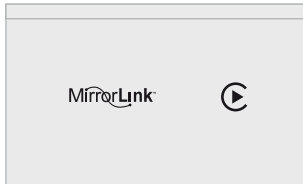

Operate certain applications on your smartphone via MirrorLink™ or CarPlay®.



Radio Media



Select an audio source, a radio station, display photographs.



Settings

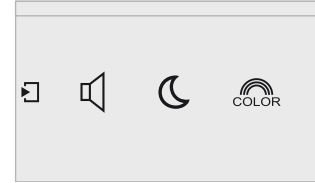

Adjust the settings for sound (balance, ambient, ...), colour schemes and the display (language, units, date, time, ...).



Telephone

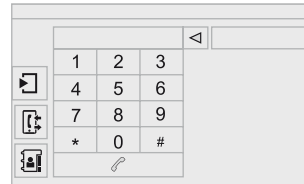

Connect a telephone by Bluetooth®. Access to the CarPlay® function after connection of your smartphone by USB cable.





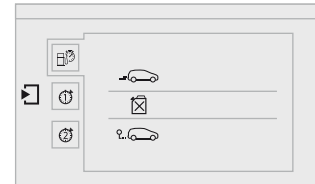





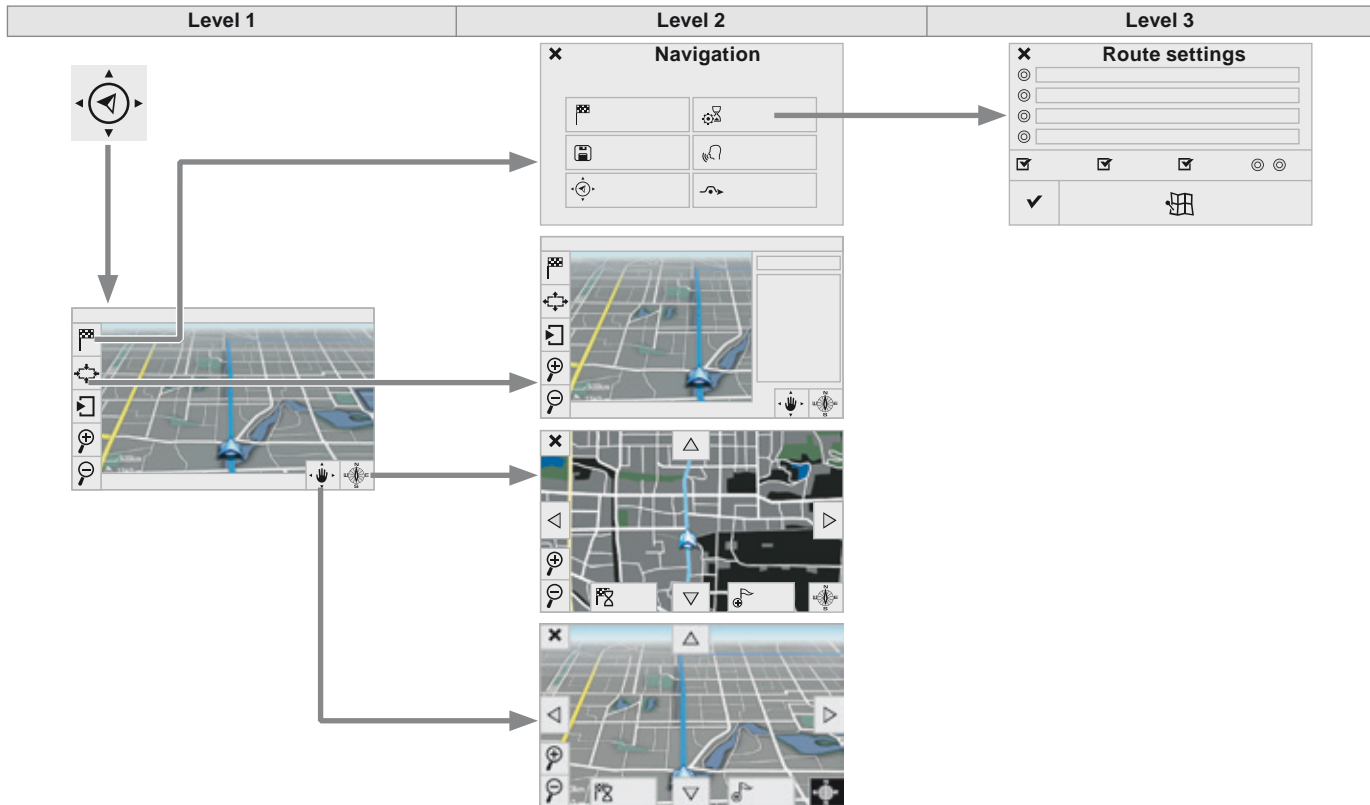







Driving











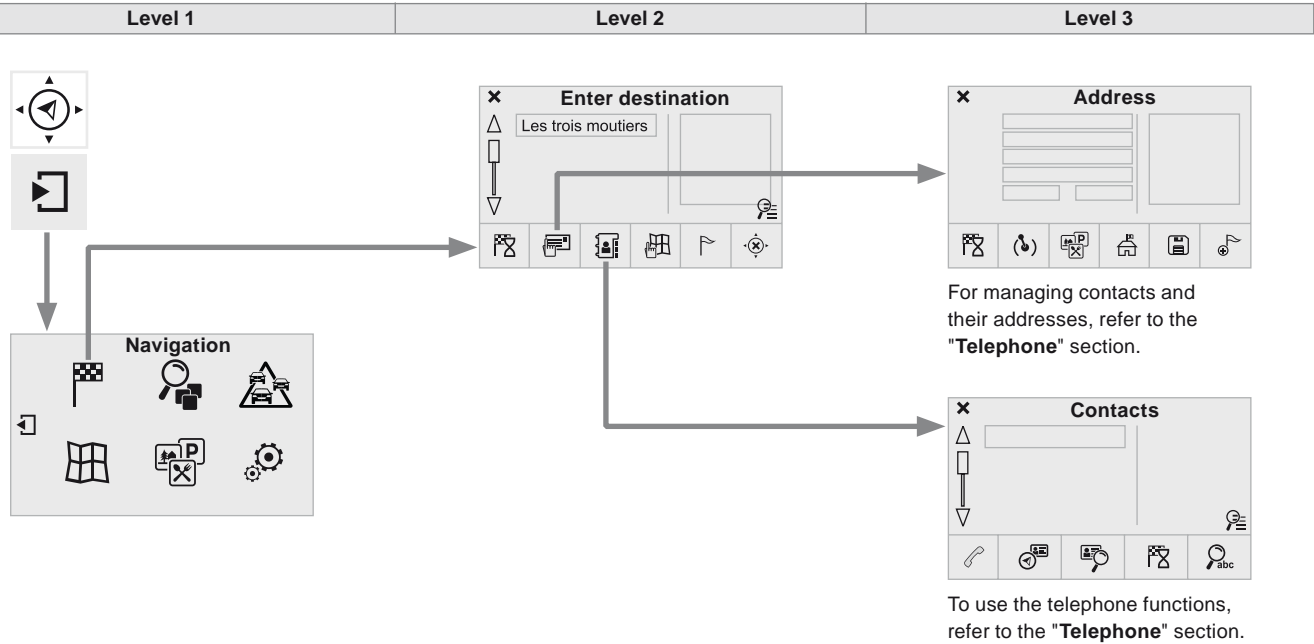











Access to the trip computer. Activate, deactivate or enter settings for certain vehicle functions.

Navigation









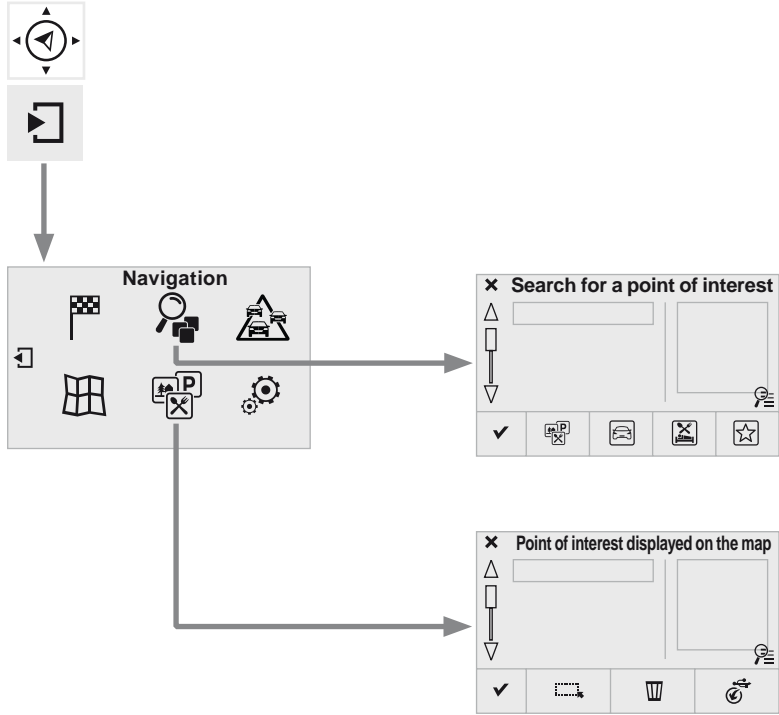





Level 1	Level 2		Level 3		Comments
  <p style="text-align: center;">Navigation ↓ Settings Navigation</p>		Enter destination			Display recent destinations.
		Route settings	<input type="radio"/>	Fastest	Choose the navigation criteria. The map displays the route chosen according to these criteria.
			<input type="radio"/>	Shortest	
			<input type="radio"/>	Time/distance	
			<input type="radio"/>	Ecological	
			<input checked="" type="checkbox"/>	Tolls	
			<input checked="" type="checkbox"/>	Ferries	
			<input checked="" type="checkbox"/>	Traffic	
			<input type="checkbox"/>	Strict-Close	
				Show route on map	Display the map and start navigation.
		<input checked="" type="checkbox"/>	Confirm	Save the options.	
		Save current location			Save the current address.
		Stop navigation			Delete the navigation information.
		Voice synthesis			Choose the volume for voice and announcement of street names.
		Diversion			Detour from your initial route by a determined distance.
					Display in text mode
					Zoom in.
					Zoom out.
					Display in full screen mode. Use the arrows to move the map.
					Switch to 2D map.









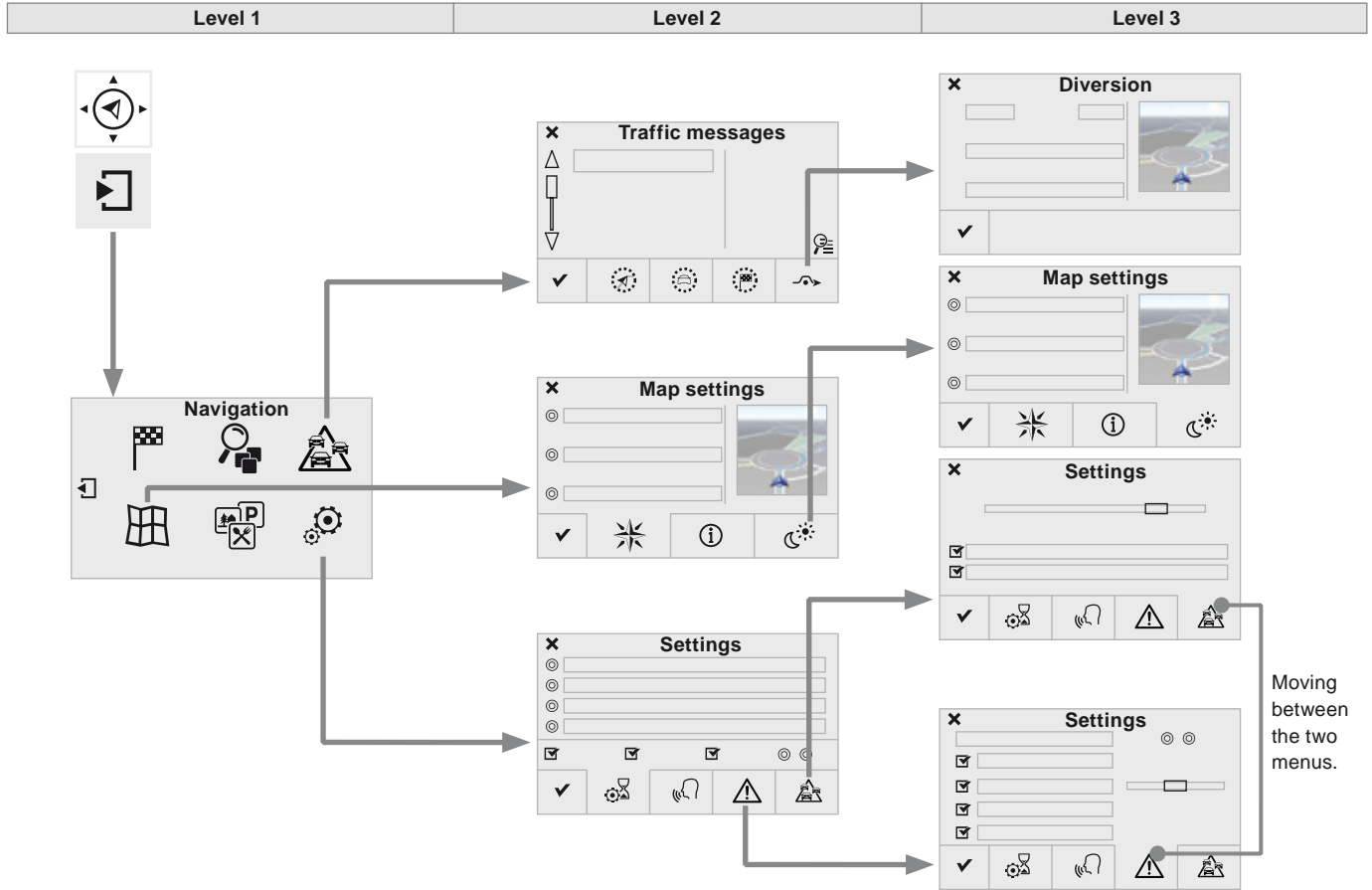













Level 1		Level 2		Level 3		Comments
  	<p style="text-align: center;"> Navigation ↓ Secondary page ↓ Enter destination </p>		<p>Address</p>	 Current loc.	Address settings	
				 Point of interest		
				 Town center		
				 Save	Save the current address.	
				 Add waypoint	Add a waypoint to the route.	
				 Navigate to	Press to calculate the route.	
			<p>Contacts</p>	 Addresses	Select a contact then calculate the route.	
				 View		
				 Navigate to		
				 Search for contact		
 Call						
	<p>On the map</p>			Display the map and zoom to view the roads.		
	<p>Itinerary</p>			Create, add or delete a waypoint or view the itinerary.		
	<p>Stop</p>			Delete navigation information.		
	<p>Navigate to</p>			Press to calculate the route.		



Level 1		Level 2		Level 3	Comments
  	Navigation	 All POIs			List of categories available. After choosing the category, select the points of interest.
	↓	 Motor			
	Secondary page	 Dining/hotels			
	↓	 Personal			
	Search for POI	<input checked="" type="checkbox"/> Search			Save the settings.
  	Navigation	 Select all			Choose the display settings for POIs.
	↓	 Delete			
	Secondary page	 Import POIs			
	↓	<input checked="" type="checkbox"/> Confirm			Save the options.
Show POIs					



Level 1		Level 2		Level 3		Comments	
  	<p>Navigation ↓ Secondary page ↓ Traffic messages</p>	 On the route				Settings for the choice of messages and the filter radius.	
		 Around vehicle					
		 Near destination					
		 Detour	<input type="radio"/>	Detour over a distance			
			<input type="radio"/>	Recalculate route			
	<input checked="" type="checkbox"/> Finish				Save your selections.		
  	<p>Navigation ↓ Secondary page ↓ Map settings</p>	 Orientation		<input type="radio"/>	Flat view north heading	Choose the display and orientation of the map.	
				<input type="radio"/>	Flat view vehicle heading		
				<input type="radio"/>	Perspective view		
		 Maps					
		 Aspect	<input type="radio"/>	"Day" map colour			
			<input type="radio"/>	"Night" map colour			
			<input type="radio"/>	Auomatic day/night			
	<input checked="" type="checkbox"/> Confirm				Save the settings.		
  	<p>Navigation ↓ Secondary page ↓ Settings</p>	 Route settings				Enter settings and choose the volume for the voice and announcement of street names.	
		 Voice					
		 Alarm!					
		 Traffic options					
			<input checked="" type="checkbox"/> Confirm				Save your selections.

Navigation - Guidance

Choosing a new destination

Towards a new destination



Press on **Navigation** to display the primary page.



Press on the secondary page.



Select "**Enter destination**".



Select "**Address**".

▼	FRANCE	⊞
▼	PARIS	⊞
▼	Blvd Hossein	⊞
N°/R	20	⊞

Select the "**Country:**" from the list offered, then in the same way the "**City:**" or its post code, the "**Road:**", the "**N°:**". Confirm each time.



Select "**Save**" to save the address entered as a contact entry. The system allows up to 200 entries.



Select "**Navigate to**".



Choose the navigation criteria: "**Fastest**" or "**Shortest**" or "**Time/distance**" or "**Ecological**".



Choose the restriction criteria: "**Tolls**", "**Ferries**", "**Traffic**", "**Strict**", "**Close**".



Select "**Confirm**".

Or



"**Show route on map**" to start navigation.



To delete navigation information, press on "**Settings**".



Press on "**Stop navigation**".



To resume navigation press on "**Settings**".



Press on "**Resume guidance**".

Towards a recent destination



Press on **Navigation** to display the primary page.



Press on the secondary page.



Select "**Enter destination**".

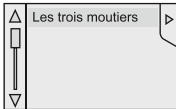

Select an address from the list offered.



Select "**Navigate to**".



Select the criteria then "**Confirm**" or press "**Show route on map**" to start navigation.

Towards a contact



To be able to use navigation "towards a contact in the directory", it is first necessary to enter the address for your contact.



Press on **Navigation** to display the primary page.



Press on the secondary page.



Select "**Enter destination**".



Select "**Contacts**".

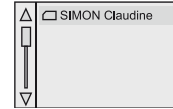

Select a destination from the contacts in the list offered.



Select "**Navigate to**".



Select the criteria then "**Confirm**" to start navigation.

Towards GPS coordinates



Press on **Navigation** to display the primary page.



Press on the secondary page.



Select "**Enter destination**".



Select "**Address**".

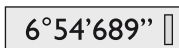

Enter the "**Longitude**:" then the "**Latitude**:".



Select "**Navigate to**".



Select the criteria then "**Confirm**" or press "**Show route on map**" to start navigation.

Towards a point on the map



Press on **Navigation** to display the primary page.



Press on the secondary page.



Select "**Enter destination**".



Select "**On the map**".

Zooming in on the map shows points with information.

A long press on a point opens its content.

Towards points of interest (POI)

Points of Interest (POI) are listed in different categories.



Press on **Navigation** to display the primary page.



Press on the secondary page.



Select "**Search for POI**".



Select "**All POIs**".

Or



"**Motor**",

Or



"**Dining/hotels**".

i An annual mapping update allows new points of interest to be presented to you.
You can also update the Risk areas / Danger areas every month.
The detailed procedure is available on:
<http://peugeot.navigation.com>.

Risk areas / Danger zone alert settings



Press on **Navigation** to display the primary page.



Press on the secondary page.



Select "**Settings**".



Select "**Alarm!**" (Alert).

It is then possible to activate Risk areas alerts then:

- "Audible warning"
- "Alert only when navigating"
- "Alert only for overspeed"
- "Display speed limits"
- Timing: the choice of timing allows the time before giving a Risk areas alert to be defined.



Select "**Confirm**".

! This series of alerts and displays is only available if Risk areas have first been downloaded and installed on the system.

Traffic

Traffic information

Display of messages



Press on **Navigation** to display the primary page.



Press on the secondary page.



Select "**Traffic messages**".

Choose filter settings for:



"**On the route**",



"**Around**",



"**Near destination**", filters to fine-tune the list of messages.

Press again to remove the filter.



Select the message from the list offered.



Select the magnifying glass to have voice information.

i TMC (Traffic Message Channel) messages on GPS-Navigation contain traffic information transmitted in real time.

Setting filters



Press on **Navigation** to display the primary page.



Press on the secondary page.



Select "**Settings**".



Select "**Traffic options**".



Select:
- "**Be advised of new messages**",
- "**Speak messages**".

Then enter the filter radius.



Select "**Confirm**".

i We recommend a filter radius of:

- 12 miles (20 km) in urban areas,
- 30 miles (50 km) on motorways.

Receiving TA messages



Press on **Navigation** to display the primary page.



Press on the secondary page.



Select "**Settings**".



Select "**Voice**".









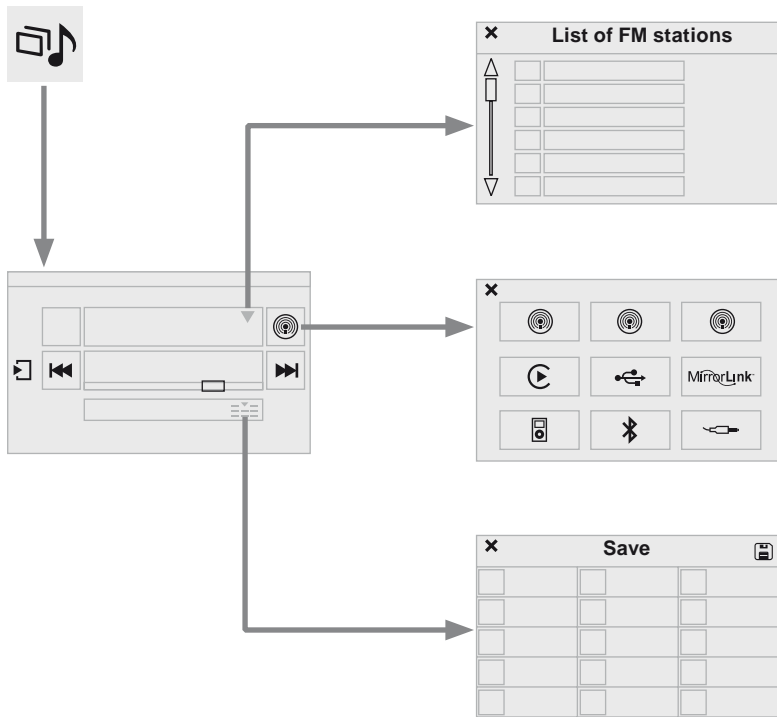







Off On

Activate / Deactivate "**Traffic (TA)**".









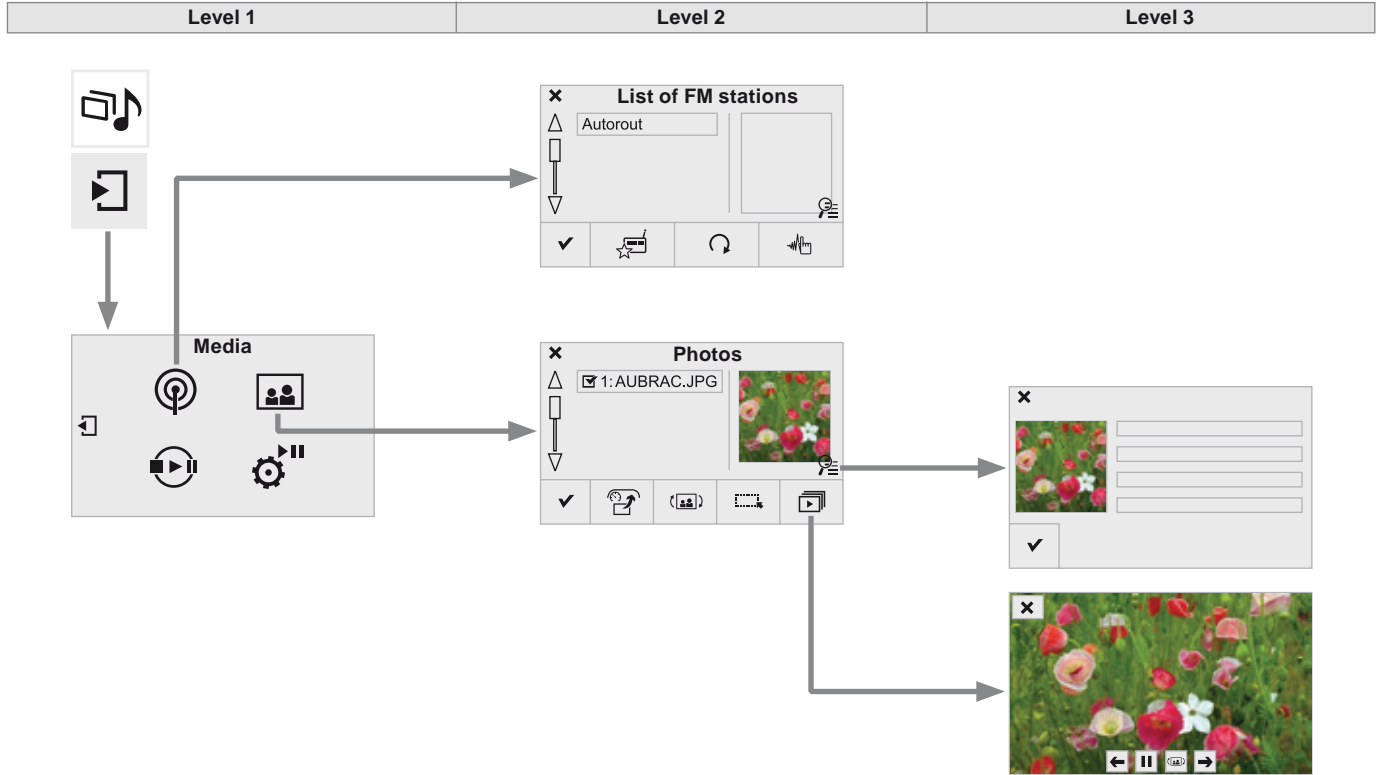









i The TA (Traffic Announcement) function gives priority to TA alert messages. To operate, this function needs good reception of a radio station transmitting this type of message. When a traffic report is transmitted, the current audio source is interrupted automatically to play the TA message. Normal playback of the audio source resumes at the end of the transmission of the message.

Radio Media









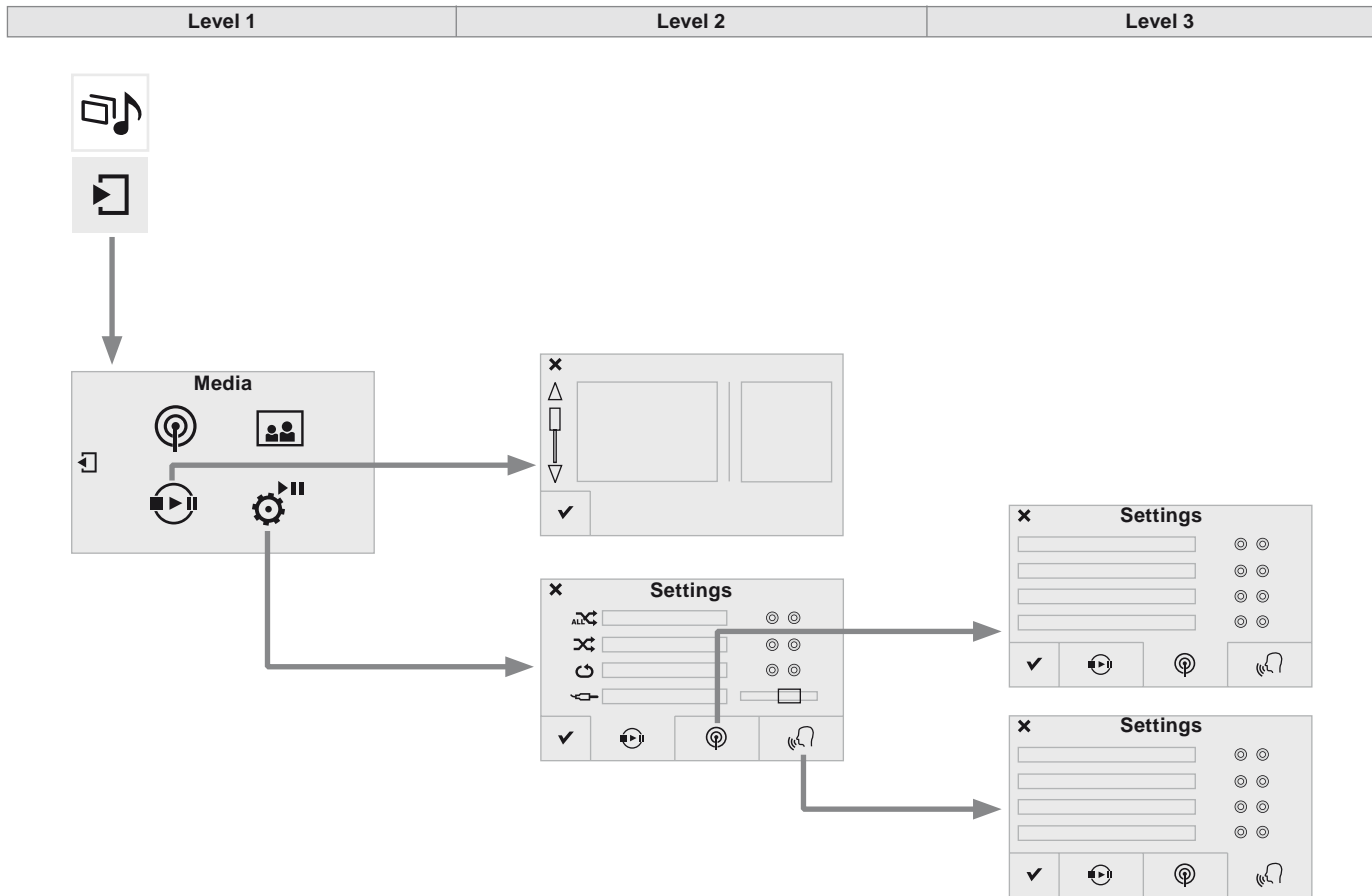







Level 1		Level 2		Comments
 	Radio Media ↓ List		List of FM stations	Press on a radio station to select it.
 	Radio Media ↓ Source	 FM Radio  DAB Radio  AM Radio  USB  MirrorLink  CarPlay  iPod  Bluetooth  AUX		Select change of source.
 	Radio Media ↓ Save (preset)			Press an empty location to Save it.



Level 1		Level 2		Level 3		Comments
  	<p>Radio Media ↓ Secondary page ↓ Radio list</p>	 Save				Press a radio station to select it.
		 Update list				Update the list of stations received.
		 Frequency				Enter the desired radio frequency.
		 Confirm				Save the settings.
  	<p>Radio Media ↓ Secondary page ↓ Photos</p>	 Home screen				Display the selected photo in the home page.
		 Rotate				Rotate the photo 90°.
		 Select all				Select all the photos in the list. Press again to deselect.
		 Slideshow	 Previous photo.			Display the photos in sequence, full-screen. The system supports the following image formats: .gif, .jpg, .bmp, .png.
			 Pause / Play.			
			 Next photo.			
 Full screen				Display the selected photo full-screen.		



Level 1		Level 2		Level 3		Comments	
	Radio Media					Presentation of the last media used.	
	Secondary page						
	Media list						
  	Radio Media ↓ Secondary page ↓ Settings		Media ↓ Settings	 Shuffle (all tracks)	Choose the play settings.		
				 Shuffle (current album)			
				 Repeat			
				 Aux. amplification			
			Radio ↓ Settings	<input type="checkbox"/> RDS options	Activate or deactivate the settings.		
				<input type="checkbox"/> DAB/FM station tracking			
				<input type="checkbox"/> Display Radio Text			
				<input type="checkbox"/> Digital radio slideshow display			
			Announcements ↓ Settings	<input type="checkbox"/> Traffic announcements (TA)	Activate or deactivate the settings.		
				<input type="checkbox"/> News - Weather			
				<input type="checkbox"/> Sport - Programm info			
				<input type="checkbox"/> Flash - Unforeseen events			
			Confirm				Save the settings.

Radio

Selecting a station

 Press on **Radio Media** to display the primary page.

 Select "**List**" in the primary page.

Or

 Press on **Radio Media** to display the primary page.

 Press on the secondary page.

 Select "**Radio list**" in the secondary page.

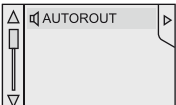
 Select a radio station from the list offered.

 Select "**Update list**" to refresh the list.

To select a preset radio station.

 Press on **Radio Media** to display the primary page.

 Select "**Save**".

 **Mémotre 1** Select a preset radio station in the list.

 If necessary, select change of source.

 Select "**FM Radio**".

Or

 "**AM Radio**".

 Radio reception may be affected by the use of electrical equipment not approved by PEUGEOT, such as a USB charger connected to the 12 V socket. The exterior environment (hills, buildings, tunnel, car park, below ground...) may prevent reception, even in RDS station tracking mode. This phenomenon is normal in the propagation of radio waves and is in no way indicative of a fault with the audio system.



Changing a radio frequency

 Press on **Radio Media** to display the primary page.

 107.7 MHz

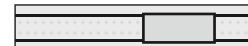
By automatic frequency search



Press  or  to move the cursor for an automatic search down or up for a radio frequency.

THEN

 Select change source.

 Select "**FM Radio**".

Or

 "**AM Radio**".

OR



Press on **Radio Media** to display the primary page.



Press on the secondary page.



Press on **Frequency**.

THEN



Enter the frequency in full (e.g.: 92.10 MHz) using the keypad then "**Confirm**".

FRANCE BLEU

Changing radio station

Pressing the name of the current radio station brings up a list.

To change radio station press the name of the desired station.

Presetting a station

Select a radio station or frequency (refer to the corresponding section).



Press on "**Save**" (preset).

Mémoire 1

Select a number in the list to preset the previously chosen radio station.

A long press on a number saves (presets) the station.

Or



A press on this button presets all of the stations one after the other.

Recalling preset stations



Press on **Radio Media** to display the primary page.



Select "**Save**" (preset).

Activating / Deactivating RDS



Press on **Radio Media** to display the primary page.



Press on the secondary page.



Select "**Settings**".



Select "**Radio**".

Off On

Activate/deactivate "**RDS options**".

i RDS, if activated, allows you to continue listening to the same station by automatic retuning to alternative frequencies. However, in certain conditions, coverage of an RDS station may not be assured throughout the entire country as radio stations do not cover 100 % of the territory. This explains the loss of reception of the station during a journey.

DAB (Digital Audio Broadcasting) radio

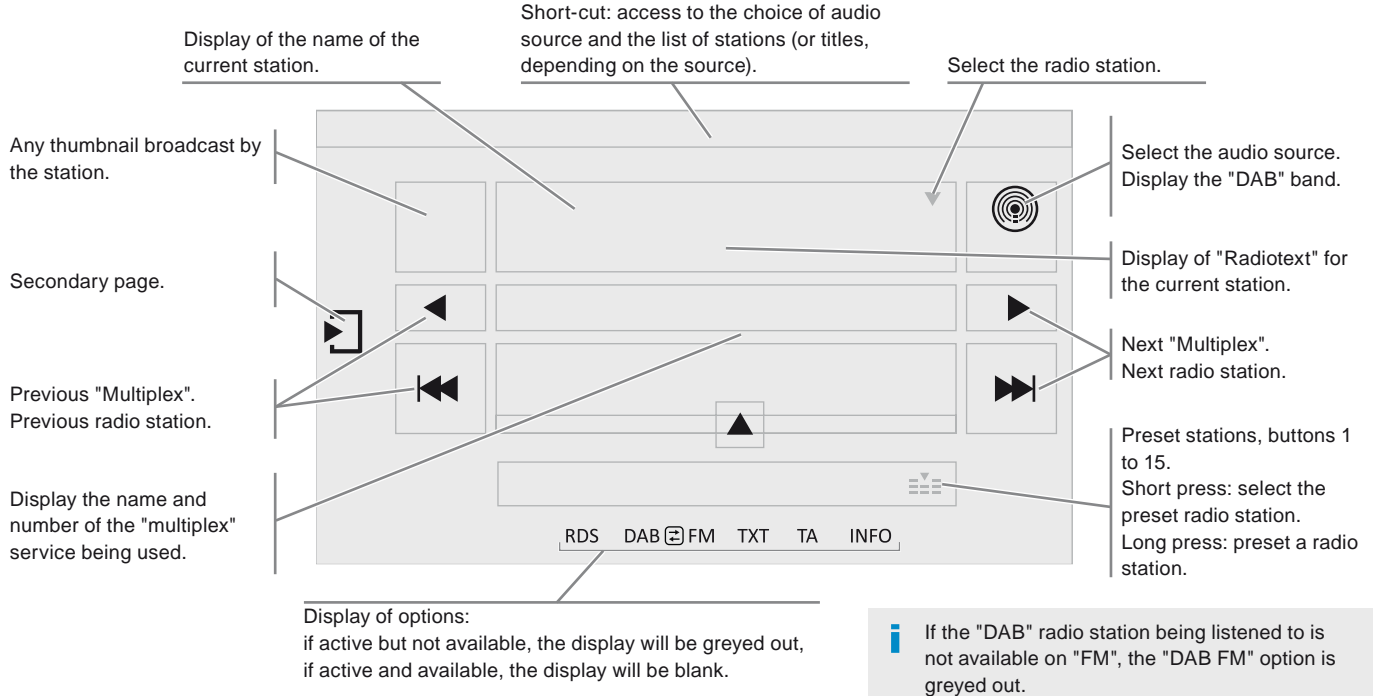

! Journaline® is a text-based information service designed for digital radio systems. It provides text-based information structured around topics and sub-topics. This service is available from the "LIST OF DAB STATIONS" page.

Digital radio

- ! Digital radio provides higher quality reception and also the graphical display of current information on the radio station being listened to. Select "List" in the primary page.
The range of multiplexes available is displayed in alphabetical order.



Press on **Radio Media** to display the primary page.



Select change of source.



Select "**DAB Radio**".



Select "**List**" in the primary page.

or

Select "**Radio list**" in the secondary page.

Select the radio station from the list offered.

DAB / FM auto tracking

- i "DAB" does not cover 100% of the territory.
When the digital radio signal is poor, "DAB/FM station tracking" allows you to continue listening to the same station, by automatically switching to the corresponding "FM" analogue station (if there is one).



Press on **Radio Media** to display the primary page.



Press on the secondary page.



Select "**Settings**".



Select "**Radio**".

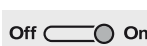

Select "**Digital/FM auto tracking**" then "**Confirm**".

- i If "DAB/FM station tracking" is activated, there is a difference of a few seconds when the system switches to "FM" analogue radio with sometimes a variation in volume.
When the digital signal is restored, the system automatically changes back to "DAB".

- ! If the "DAB" station being listened to is not available on "FM" ("**DAB/FM**" option greyed out), or "DAB/FM station tracking" is not activated, the sound will cut out while the digital signal is too weak.

Media

USB port

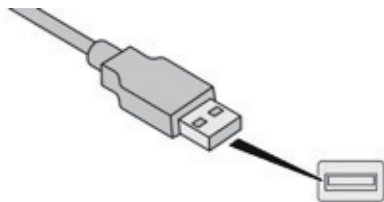

Insert the USB memory stick into the USB port or connect the USB device to the USB port using a suitable cable (not supplied).

! To protect the system, do not use a USB hub.

The system builds playlists (in temporary memory), an operation which can take from a few seconds to several minutes at the first connection.
Reduce the number of non-music files and the number of folders to reduce the waiting time.
The playlists are updated every time the ignition is switched off or on connection of a USB memory stick. The lists are memorised: if they are not modified, the subsequent loading time will be shorter.

Auxiliary socket (AUX)



This source is only available if the "Auxiliary socket" option has been activated in the "Media" settings.

Connect the portable device (MP3 player...) to the auxiliary Jack socket using an audio cable (not supplied).

First adjust the volume of your portable device (to a high level). Then adjust the volume of your audio system.
Display and management of the controls are via the portable device.

Selection of source



Press on **Radio Media** to display the primary page.



Select change of source.

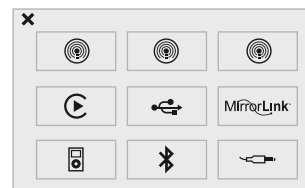

Choose the source.



The steering mounted **SRC** (source) button can be used to go to the next media source, available if the source is active.

Information and advice

The audio system will only play audio files with ".wma", ".aac", ".flac", ".ogg" and ".mp3" file extensions and with a bit rate of between 32 Kbps and 320 Kbps.
It also supports VBR (Variable Bit Rate) mode. No other type of file (.mp4, ...) can be played.
".wma" files must be of the standard wma 9 type.
The sampling rates supported are 32, 44 and 48 KHz.

It is advisable to restrict file names to 20 characters, without using special characters (e.g. " " ? ; ù) to avoid any playing and displaying problems.

! The system supports USB mass storage portable players, BlackBerry® devices or Apple® players via USB ports. The adaptor cable is not supplied. Control of the peripheral device is with the audio system controls. Other peripheral devices, not recognised by the system on connection, must be connected to the auxiliary socket using a Jack cable (not supplied).

Use only USB memory sticks formatted FAT32 (file allocation table).

! To protect the system, do not use a USB hub.

i It is recommended that the USB cable for the portable device is used.

Bluetooth® audio streaming

Streaming allows audio files on your telephone to be played through the vehicle's speakers.

Connect the telephone: see the "**Telephone**" section, then "**Bluetooth**". Choose the "**Audio**" or "**All**" profile.

If play does not start automatically, it may be necessary to start the audio playback from the telephone.

Control is from the peripheral device or by using the audio system buttons.

! Once connected in streaming mode, the telephone is considered to be a media source. It is recommended that you activate "**Repeat**" on the Bluetooth® peripheral.

Connecting Apple® players

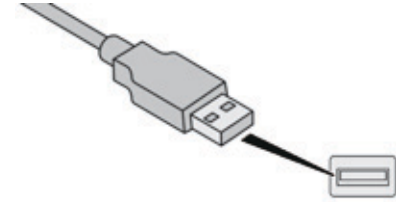









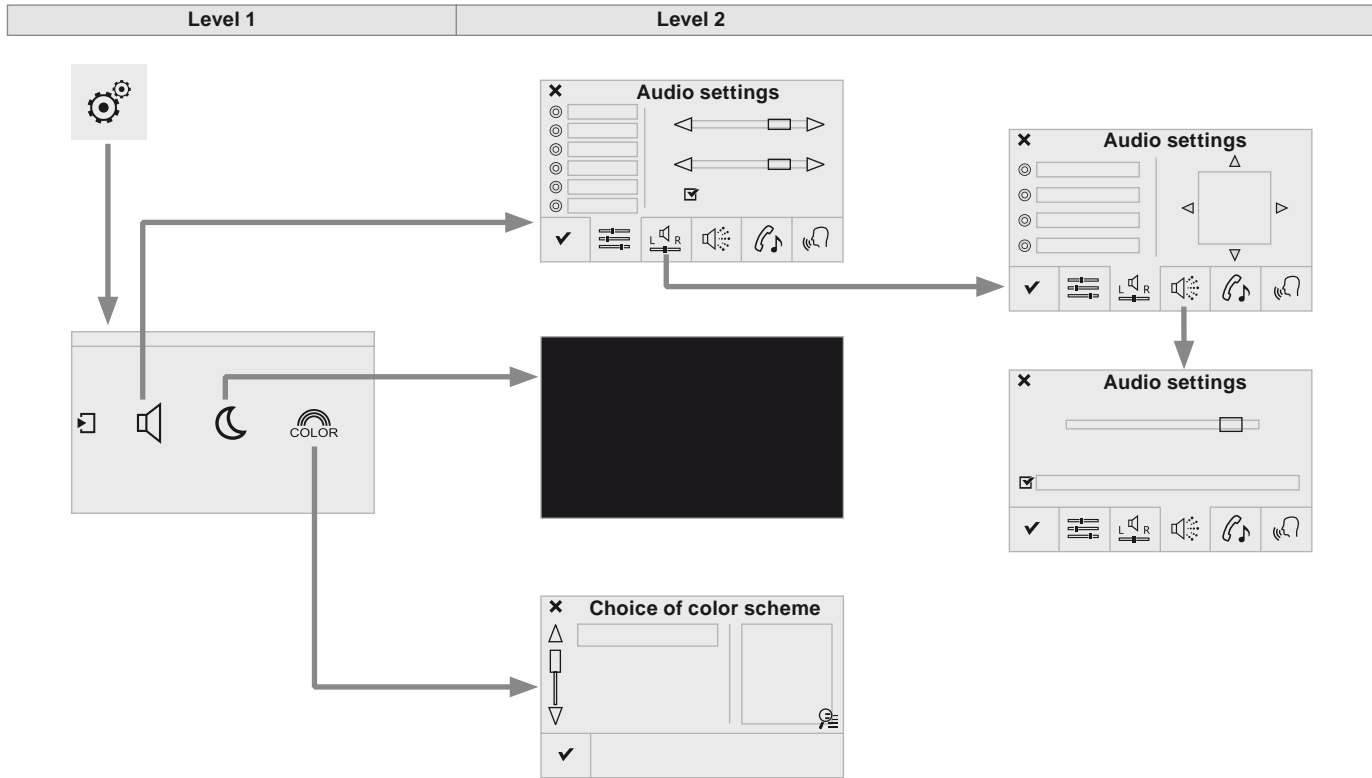





Connect the Apple® player to the USB port using a suitable cable (not supplied). Play starts automatically. Control is via the audio system.

i The classifications available are those of the portable device connected (artists / albums / genres / playlists / audiobooks / podcasts). The default classification used is by artist. To modify the classification used, return to the first level of the menu then select the desired classification (playlists for example) and confirm to go down through the menu to the desired track.









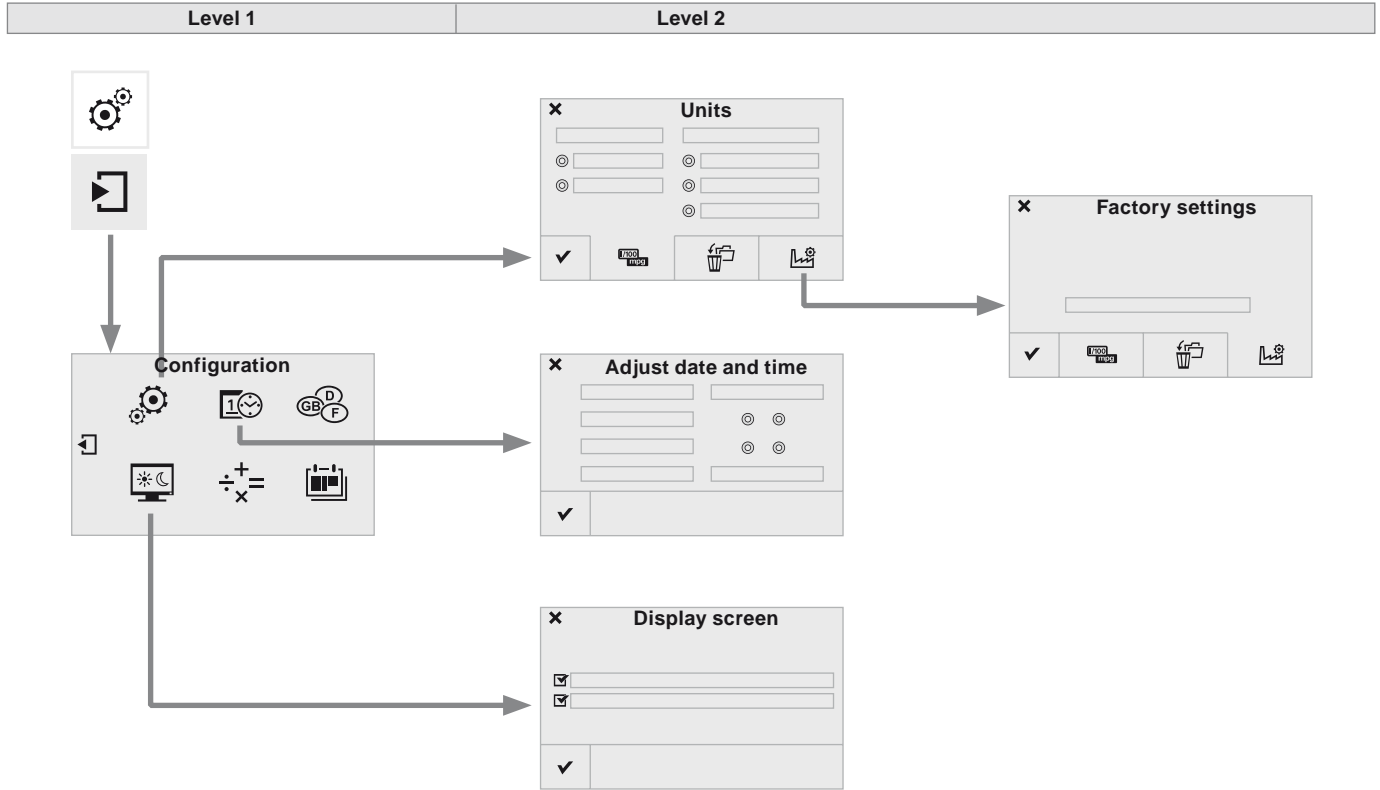



The version of software in the audio system may not be compatible with the generation of your Apple® player.

Settings









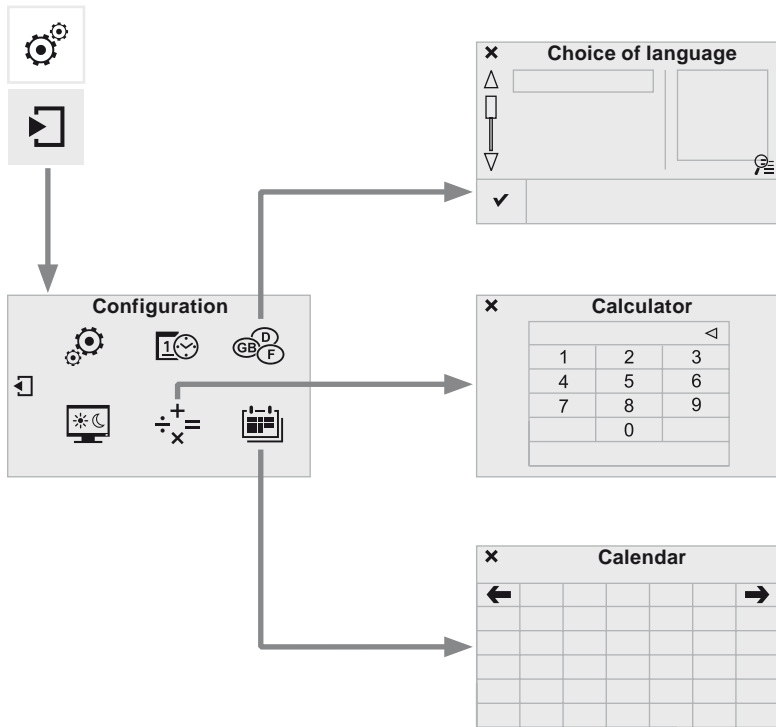

Level 1		Level 2		Comments
 	Settings ↓ Audio settings		Ambience	Choose the sound ambience.
			Balance	Sound distribution using the Arkamys® system.
			Sound effects	Set the volume or activate the link to vehicle speed.
			Ringtones	Set the telephone ringtone and volume.
			Voice	Set the volume and voice for speaking street names
			Confirm	Save your settings.
 	Settings ↓ Turn off screen			Function that turns off the display. Pressing the screen reactivates it.
 	Settings ↓ Color schemes		Confirm	Choose the color scheme, then confirm to save the setting.



Level 1		Level 2		Comments
  	Settings ↓ Secondary page ↓ System Settings	 Units	Set the units used to display distance, fuel consumption and temperature.	
		 Delete data	Select the desired data in the list then press Delete.	
		 Factory settings	Return to factory settings.	
		✓ Confirm	Save the settings.	
  	Settings ↓ Secondary page ↓ Time/Date	✓ Confirm	Set the date and time then confirm.	
  	Settings ↓ Secondary page ↓ Screen settings	<input checked="" type="checkbox"/> Activate automatic text scrolling	Activate or deactivate the setting then confirm.	
	<input checked="" type="checkbox"/> Activate animations			
	✓ Confirm			



Level 1		Level 2		Comments
  	<p>Settings</p> <p>↓</p> <p>Secondary page</p> <p>↓</p> <p>Languages</p>	✓	Confirm	Select the language then confirm.
  	<p>Settings</p> <p>↓</p> <p>Secondary page</p> <p>↓</p> <p>Calculator</p>			Select the calculator.
  	<p>Settings</p> <p>↓</p> <p>Secondary page</p> <p>↓</p> <p>Calendar</p>			Select the calendar.

Audio settings



Press on **Settings** to display the primary page.



Select "**Audio settings**".



Select "**Ambience**".

Or



"**Balance**"

Or



"**Sound effects**"

Or



"**Ringtones**"

Or



"**Voice**".

! The distribution (or spatialisation using the Arkamys® system) of sound is an audio process that allows the audio quality to be adapted to the number of passengers in the vehicle. Available only with the 6-speaker configuration.

! The audio settings (**Ambience**, **Bass**., **Treble**: and **Loudness**) are different and independent for each sound source. The settings for **Distribution** and **Balance** are common to all sources.

!

- "**Ambience**" (choice of 6 musical ambiances)
- "**Bass**:"
- "**Treble**:"
- "**Loudness**" (Activate/Deactivate)
- "**Distribution**" ("**Driver**", "**All passengers**", "**Front only**")
- "**Audible response from touch screen**"
- "**Volume linked to speed**" (Activate/Deactivate)

i On-board audio: Arkamys® Sound Staging optimises sound distribution in the passenger compartment.

Color schemes



Press on **Settings** to display the primary page.



Select "**Color schemes**".



Select the color scheme in the list then "**Confirm**".

i At each change of color scheme the system restarts, showing a black screen for a few moments.

! As a safety measure, the procedure for changing the color scheme is only possible with the vehicle stationary.

Modifying system settings

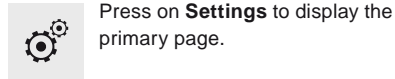

Press on **Settings** to display the primary page.

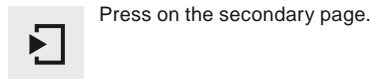

Press on the secondary page.

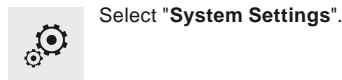

Select "**System Settings**".

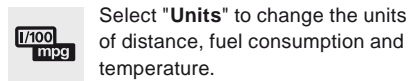

Select "**Units**" to change the units of distance, fuel consumption and temperature.



Select "**Delete data**" to delete the list of recent destinations, personal points of interest, contacts in the list.

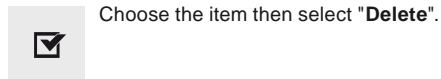

Choose the item then select "**Delete**".



Select "**Factory settings**" to return to the original settings.

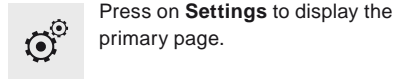

Press on **Settings** to display the primary page.

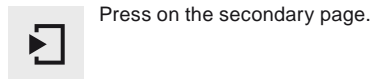

Press on the secondary page.

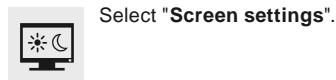

Select "**Screen settings**".

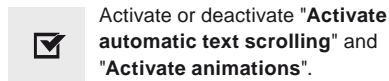

Activate or deactivate "**Activate automatic text scrolling**" and "**Activate animations**".

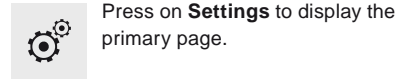

Press on **Settings** to display the primary page.

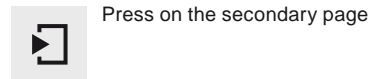

Press on the secondary page

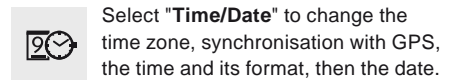

Select "**Time/Date**" to change the time zone, synchronisation with GPS, the time and its format, then the date.

i The system does not manage changes between summer time and winter time automatically (according to country).

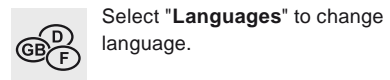

Select "**Languages**" to change language.

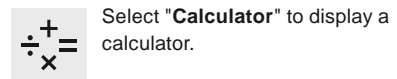

Select "**Calculator**" to display a calculator.

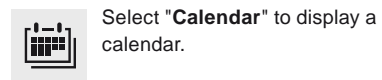

Select "**Calendar**" to display a calendar.

Connected services

MirrorLink™

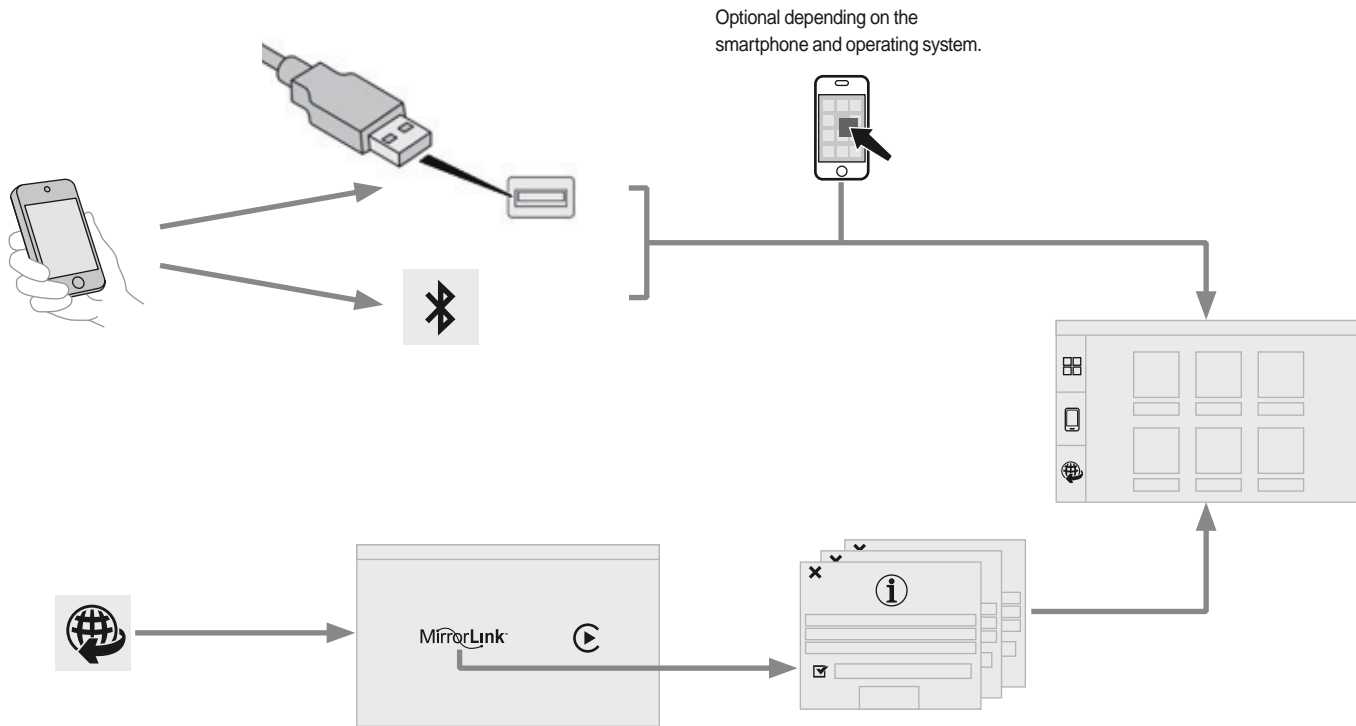

MirrorLink™ smartphone connection

! As a safety measure and because it requires sustained attention by the driver, using a smartphone when driving is prohibited. All operations must be done with the **vehicle stationary**.

i The synchronisation of a smartphone allows applications on a smartphone that are adapted to the MirrorLink™ technology to be displayed in the vehicle's screen. The principles and standards are constantly evolving. For the communication process between the smartphone and the system to work correctly, the smartphone must be unlocked; update the operating system of your smartphone as well as the date and time in the smartphone and the system. For the list of eligible smartphones, connect to the brand's internet website in your country.

! As a safety measure, applications can only be viewed with the vehicle stationary; display is interrupted once the vehicle is moving.

i Please note:

- if your smartphone is supported, to make it "MirrorLink™" compatible, some phone manufacturers nevertheless invite you to first download a dedicated application.



When connecting a smartphone to the system, it is recommended that Bluetooth® be started on the smartphone.



Connect a USB cable. The smartphone charges when connected by a USB cable.



From the system, press on "**Connected services**" to display the primary page.

MirrorLink

Press on "**MirrorLink™**" to start the application in the system.



Start the application on the smartphone (optional, depending on the smartphone and operating system).

OK

During the procedure, several screen pages relating to certain functions are displayed. Accept to start and end the connection.

Once connection is established, an page is displayed with the applications already downloaded to your smartphone and adapted to MirrorLink™ technology. If only one application has been downloaded to the smartphone, it starts automatically.





Access to the different audio sources remains accessible in the margin of the MirrorLink™ display, using touch buttons in the upper bar. Access to the menus for the system is possible at any time using the dedicated buttons

Voice recognition

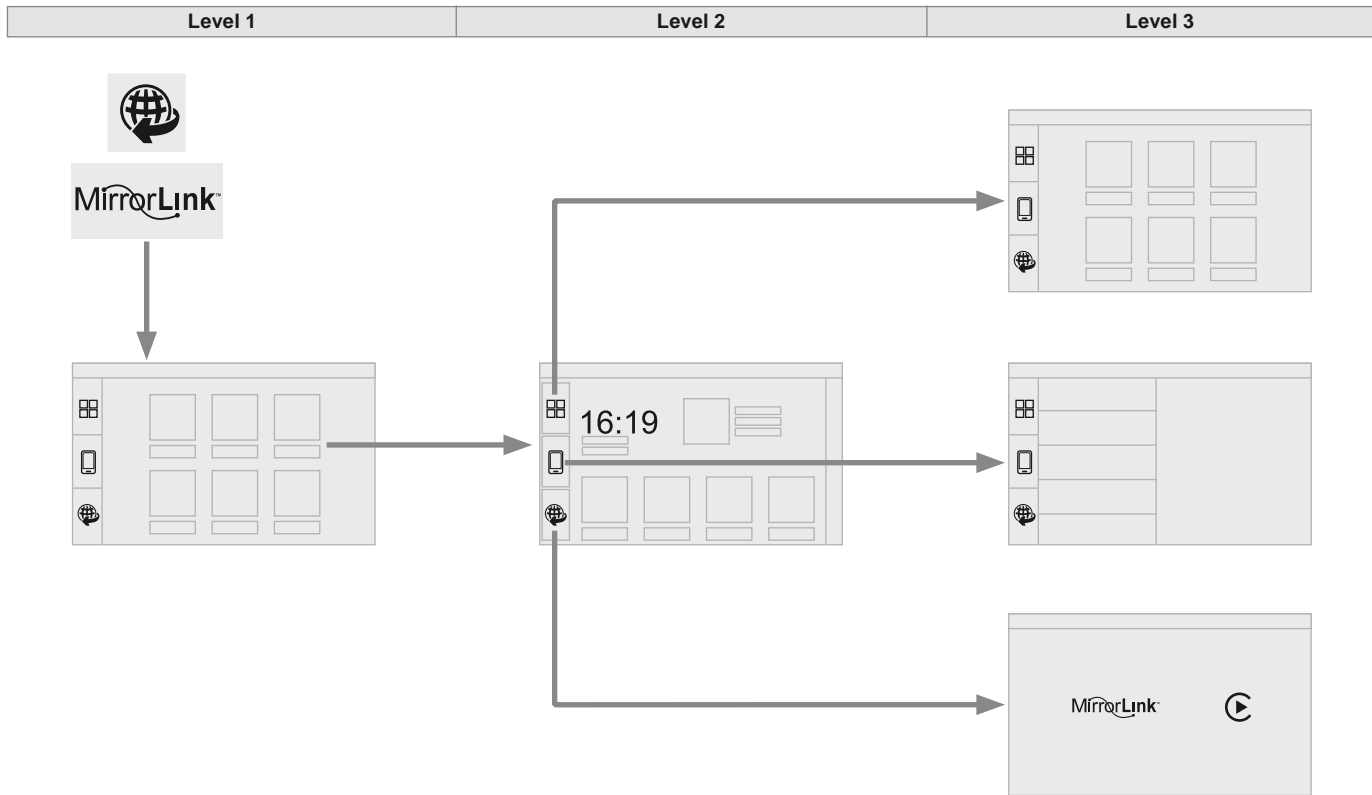
Press the end of the lighting control stalk to start voice recognition of your smartphone via the system.

Voice recognition requires a compatible smartphone connected to the vehicle by Bluetooth®.



Level 1		Level 2		Level 3		Comments
 	<p>Connected services</p> <p>↓</p> <p>MirrorLink™</p>					Access or return to the applications already downloaded to your smartphone and adapted to MirrorLink™ technology.
						Access to a menu list depending on the application chosen. "Back": abandon the current operation, go up one level. "Home": access or return to the "Car mode" page.
						Access to the "Connected services" primary page.

CarPlay®

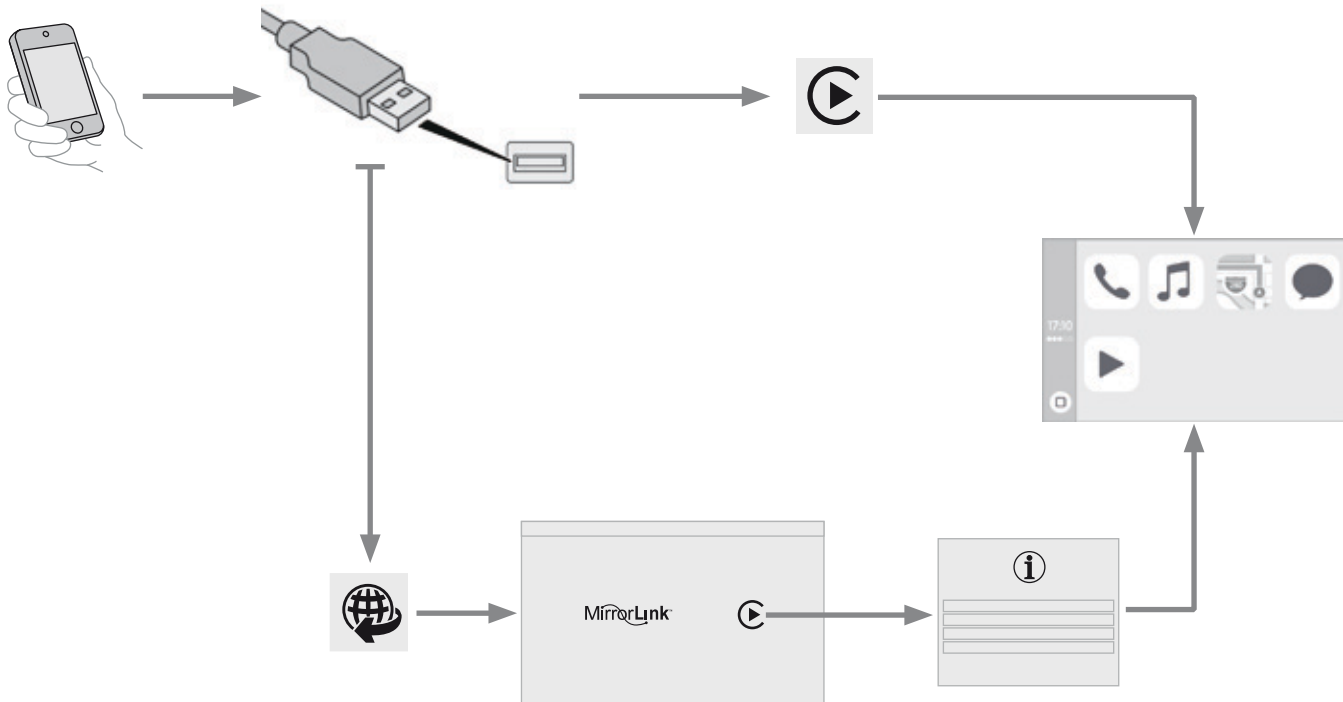

CarPlay® smartphone connection

! As a safety measure and because it requires sustained attention by the driver, using a smartphone when driving is prohibited. All operations must be done with the **vehicle stationary**.

i The synchronisation of a smartphone allows applications on a smartphone that are adapted to the CarPlay® technology to be displayed on the vehicle's screen. As the principles and standards are constantly evolving, it is recommended that you update the operating system of your smartphone. For the list of eligible smartphones, connect to the brand's internet website in your country.

i As a safety measure, applications can only be viewed with the vehicle stationary; display is interrupted once the vehicle is moving.



Connect a USB cable. The smartphone charges when connected by a USB cable.



On connecting the USB cable, the **"Telephone"** function changes to **"CarPlay"** in the menu carousel. Press on **"CarPlay"** to display the CarPlay® interface.

Or



Connect the USB cable. The smartphone is charged while connected by the USB cable.



From the system, press on **"Connected services"** to display the primary page.



Press on **"CarPlay"** to display the CarPlay® interface.

i During the procedure, one or more screen pages relating to certain functions are displayed on connection.

When the telephone menu is displayed, connection of the USB cable causes the display to automatically change to CarPlay mode.









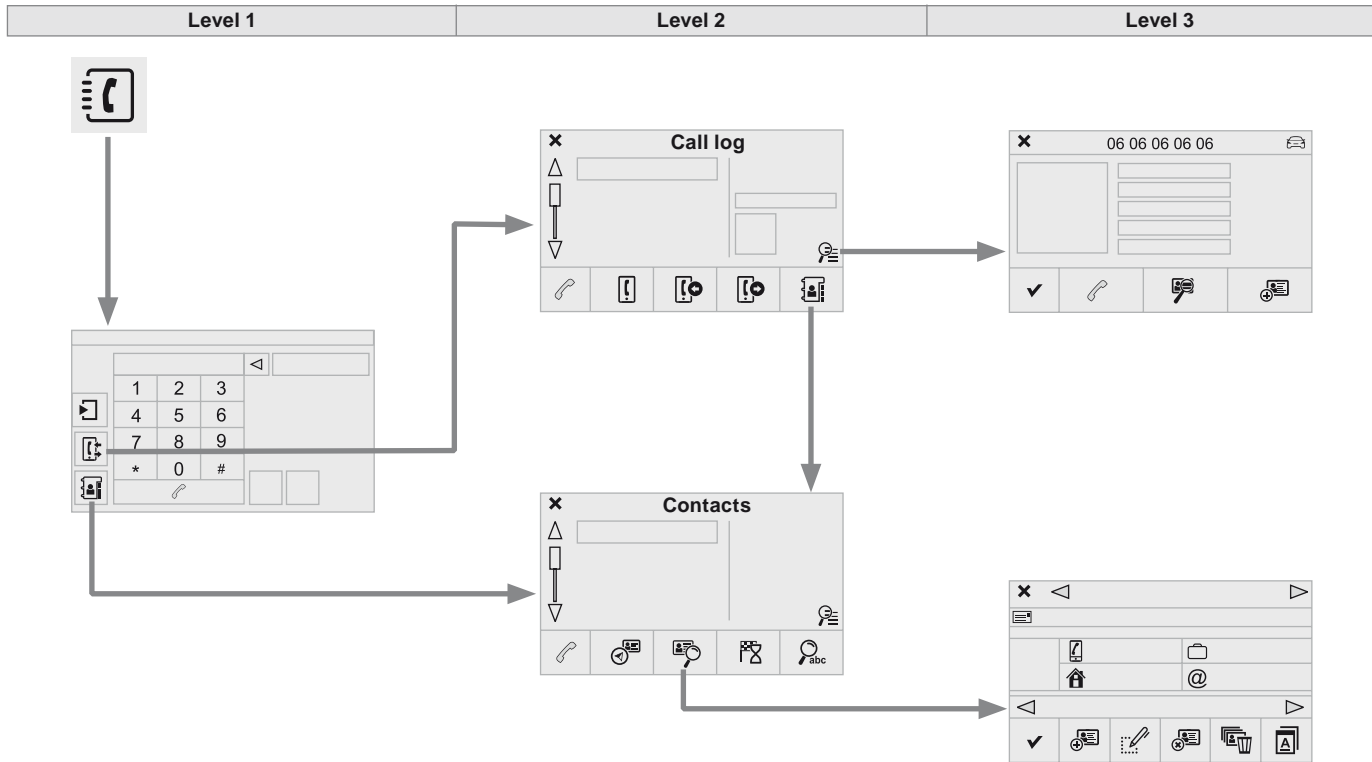













When another menu is displayed, on connection of a USB cable a message is displayed in the upper bar, indicating that CarPlay mode has been activated. Press Open to display CarPlay mode.

Voice recognition









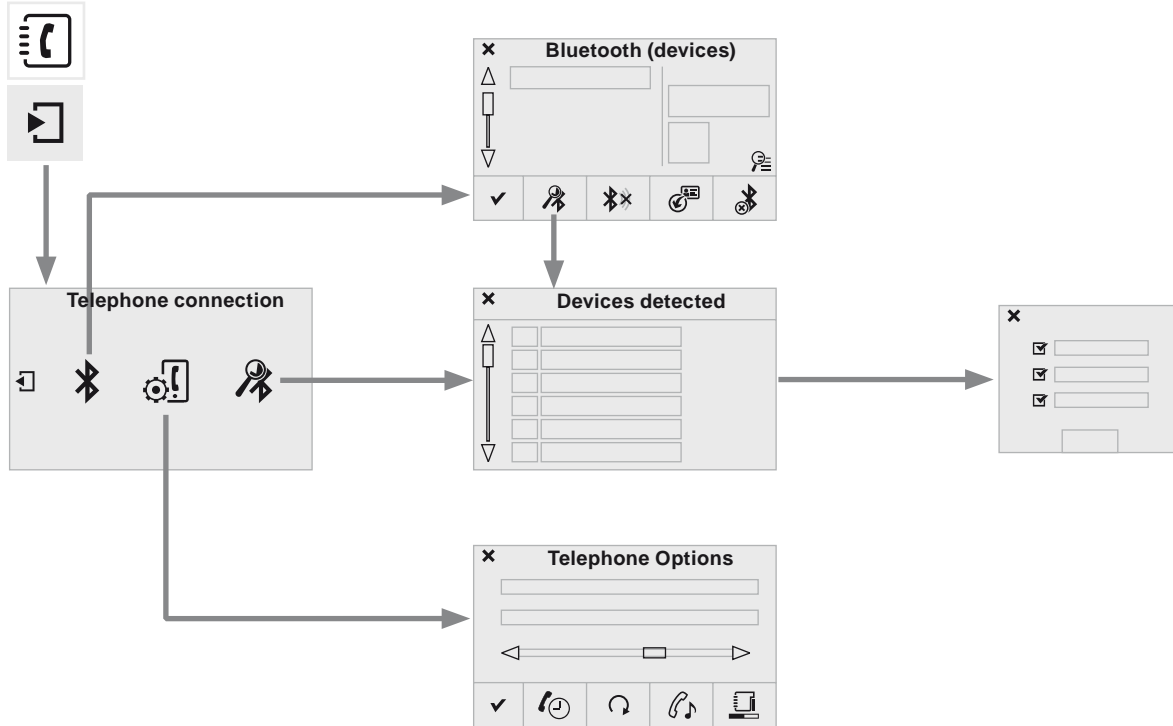









Press the end of the lighting control stalk to start voice recognition of your smartphone via the system.

Telephone



Level 1		Level 2		Level 3		Comments
 	<p>Telephone ↓ Call log</p>	 All calls				After making choices, start the call.
		 Incoming calls				
		 Outgoing calls				
		 Contacts				
		 Magnifying glass	 View			
			 Create			
 Call						
 	<p>Telephone ↓ Contacts</p>	 Addresses				After making choices, start the call.
		 View	 Create			
			 Modify			
			 Delete			
			 Delete all			
			 By name			
			 Confirm			
		 Navigate to				
		 Search for contact				
 Call						



Level 1		Level 2		Level 3		Comments
  	Telephone connection ↓ Secondary page ↓ Bluetooth connection	 Search				Start the search for another peripheral device to connect.
		 Connect / Disconnect				Start or stop the Bluetooth® connection to the selected peripheral device.
		 Update				Import the contacts from the selected telephone to store them in the audio system.
		 Delete				Delete the selected telephone.
		 Confirm				Save the settings.
  	Telephone connection ↓ Secondary page ↓ Search for devices			<input checked="" type="checkbox"/> Telephone		Start the search for peripheral devices.
		Devices detected		<input checked="" type="checkbox"/> Audio streaming		
				<input checked="" type="checkbox"/> Internet		
  	Telephone connection ↓ Secondary page ↓ Telephone Options	 Put on hold				Cut the microphone temporarily so that the contact cannot hear your conversation with a passenger.
		 Update				Import the contacts from the selected telephone to save then in the audio system.
		 Ringtones				Choose the telephone ringtone and volume.
		 Memory info.				Contact records used and free, percentage of storage space used by internal contacts and Bluetooth® contacts.
		 Confirm				Save the settings.

Pairing a Bluetooth® telephone

! For reasons of safety and because they require prolonged attention on the part of the driver, the operations for pairing the Bluetooth® mobile telephone to the hands-free system of the audio system must be carried out with the **vehicle stationary**.

Procedure (short) from the telephone

In the Bluetooth® menu of your device, select the system name in the list of devices detected.

Enter a code of at least 4 figures in the device and confirm.



Enter this same code in the system, select **"OK"** and confirm.

Procedure from the system

Activate the telephone's Bluetooth® function and ensure that it is "visible to all" (telephone configuration).



Press on **Telephone** to display the primary page.



Press on the secondary page.



Select **"Bluetooth connection"**.



Select **"Search for devices"**.
The list of telephones detected is displayed.



If the telephone is not detected, it is recommended that you switch the Bluetooth® function on your telephone off and then on again.

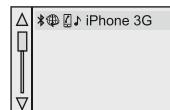

Select the name of the desired peripheral from the list and **"Confirm"**.



Enter a code of at least 4 figures for the connection then **"Confirm"**.

Enter this same code in the telephone then accept the connection.

The system offers to connect the telephone:

- in **"Telephone"** (hands-free kit, telephone only),
- in **"Audio streaming"** (streaming: wireless playing of audio files from the telephone),
- in **"Internet"** (internet browsing, only if your telephone is compatible with the "DUN" Dial-Up Networking Bluetooth® standard).

Select one or more profiles and confirm.

! The services available depend on the network, the SIM card and the compatibility of the Bluetooth® telephone used. Check the telephone manual and with your network provider for details of the services available to you.

! The ability of the system to connect with only one profile depends on the telephone. The three profiles may all connect by default.

Visit www.peugeot.co.uk for more information (compatibility, additional help, ...).

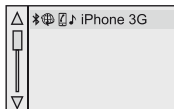

The recognised telephone appears in the list.

Depending on your telephone, you may be asked to accept automatic connection every time the ignition is switched on.

! Depending on the type of telephone, the system will ask you to accept or not the transfer of your contacts.



If not, select "**Update**".

On return to the vehicle, if the last telephone connected is present again, it is reconnected automatically and within around 30 seconds after switching on the ignition the pairing is done without any action on your part, with (Bluetooth® activated).

To modify the automatic connection mode, select the telephone in the list then select the desired profile.

Connecting a Bluetooth® peripheral device

Automatic reconnection

On switching on the ignition, the telephone connected when the ignition was last switched off is automatically reconnected, if this connection mode had been activated during the pairing procedure.

The connection is confirmed by the display of a message and the name of the telephone.

Manual connection



Press on **Telephone** to display the primary page.



Press on the secondary page.



Select "**Bluetooth**" to display the list of paired peripherals.

Select the peripheral to connect.



Press on "**Search for devices**".

The connection is confirmed by the display of a message and the name of the telephone.

Managing paired telephones

i This function allows the connection or disconnection of a peripheral device as well as the deletion of a pairing.



Press on **Telephone** to display the primary page.



Press on the secondary page.



Select "**Bluetooth**" to display the list of paired peripheral devices.

Select the peripheral in the list.



Select "**Search for devices**"

Or



"**Connect / Disconnect**" to start or end the Bluetooth connection with the selected device.

Or



"**Delete**" to delete the pairing.

Receiving a call

An incoming call is announced by a ring and a superimposed display in the screen.



Make a short press on the steering mounted **TEL** button to accept an incoming call.



Make a long press



on the steering mounted **TEL** button to reject the call.

Or



Select "**End call**".

Making a call

! Using the telephone is not recommended while driving. Park the vehicle. Make the call using the steering mounted controls.

Calling a new number



Press on **Telephone** to display the primary page.



Enter the phone number using the digital keypad. Press "**Call**" to start the call.

Calling a contact



Press on **Telephone** to display the primary page.



Or make a long press



on the steering mounted **TEL** button.



Select "**Contacts**".

Select the desired contact from the list offered.



Select "**Call**".

Calling a recently used number



Press on **Telephone** to display the primary page.



Select "**Call log**".

Select the desired contact from the list offered.



It is always possible to make a call directly from the telephone; park the vehicle first as a safety measure.

Managing contacts / entries



Press on **Telephone** to display the primary page.



Select "**Contacts**".



Select "**View**".



Select "**Create**" to add a new contact, observing the "international format".

Or



"**Modify**" to edit the selected contact.

Or



"**Delete**" to delete the selected contact.

Or



"**Delete all**" to delete all information for the selected contact.



Select "**By name**" to view the list of contacts.

Frequently asked questions

The table below gives answers to the most frequently asked questions on your audio system.

Navigation

QUESTION	ANSWER	SOLUTION
The route calculation is not successful.	The navigation settings may conflict with the current location (exclusion of toll roads on a toll motorway).	Check the settings in the "Navigation" menu.
The POIs do not appear.	The POIs have not been selected.	Select the POIs in the list of POIs.
The Risk areas audible warning does not work.	The audible warning is not active.	Activate audible warnings in the "Navigation" menu.
The system does not suggest a detour around an incident on the route.	The guidance criteria do not take account of TMC messages.	Select the "Information" function in the list of guidance criteria.
I receive a Risk areas alert which is not on my route.	Other than guidance, the system announces all Risk areas positioned in a cone located in front of the vehicle. It may provide an alert for Risk areas located on nearby or parallel roads.	Zoom in on the map to view the exact position of the Risk areas. Select "On the route" to no longer receive alerts other than guidance or to reduce the time for the announcement.

QUESTION	ANSWER	SOLUTION
Certain traffic jams along the route are not indicated in real time.	On starting, it is several minutes before the system begins to receive the traffic information.	Wait until the traffic information is being received correctly (display of the traffic information icons on the map).
	The filters are too restrictive.	Modify the settings.
	In certain countries, only major routes (motorways...) are listed for the traffic information.	This phenomenon is normal. The system is dependent on the traffic information available.
The altitude is not displayed.	On starting, the initialisation of the GPS may take up to 3 minutes to receive more than 4 satellites correctly.	Wait until the system has completed starting up, so that there is GPS coverage of at least 4 satellites.
	Depending on the geographical environment (tunnel...) or the weather, the conditions of reception of the GPS signal may vary.	This phenomenon is normal. The system is dependent on the GPS signal reception conditions.

Radio

QUESTION	ANSWER	SOLUTION
<p>The quality of reception of the radio station listened to gradually deteriorates or the stored stations do not function (no sound, 87.5 Mhz is displayed...).</p>	<p>The vehicle is too far from the transmitter used by the station listened to or there is no transmitter in the geographical area through which the vehicle is travelling.</p>	<p>Activate the "RDS" function by means of the short-cut menu to enable the system to check whether there is a more powerful transmitter in the geographical area.</p>
	<p>The environment (hills, buildings, tunnels, basement car parks...) block reception, including in RDS mode.</p>	<p>This phenomenon is normal and does not indicate a fault with the audio system.</p>
	<p>The aerial is absent or has been damaged (for example when going through a car wash or into an underground car park).</p>	<p>Have the aerial checked by a PEUGEOT dealer.</p>
<p>I cannot find some radio stations in the list of stations received.</p>	<p>The station is not received or its name has changed in the list.</p>	<p>Press on the "Update list" function in the system to update the list of stations received.</p>
	<p>Some radio stations send other information in place of their name (the title of the song for example). The system interprets this information as the name of the station.</p>	

Media

QUESTION	ANSWER	SOLUTION
Playback of my USB memory stick starts only after a very long wait (around 2 to 3 minutes).	Some files supplied with the memory stick may greatly slow down access to reading the memory stick (multiplication by 10 of the catalogue time).	Delete the files supplied with the memory stick and limit the number of sub-folders in the file structure on the memory stick.
When I connect my iPhone as telephone and to the USB port at the same time, I am unable to play the music files.	When the iPhone connects automatically as a telephone, it forces the streaming function. The streaming function takes the place of the USB function which is then not useable, there is a period without sound of the track being played with Apple® players.	Disconnect and reconnect to the USB port (the USB function takes priority over streaming).
Some characters in the media information are not displayed correctly while playing.	The audio system does not display some types of characters.	Use standard characters to name tracks and folders.
Playing of streaming files does not start.	The peripheral device connected does not support automatic play.	Start the playback from the device.
The names of tracks and the track length are not displayed on the screen when streaming audio.	The Bluetooth profile does not allow the transfer of this information.	

Settings

QUESTION	ANSWER	SOLUTION
<p>In changing the setting of treble and bass the equalizer setting is deselected.</p>	<p>The selection of an equalizer setting imposes the balance settings. Modifying one without the other is not possible.</p>	<p>Modify the balance or equalizer settings to obtain the desired musical ambience.</p>
<p>In changing the equalizer setting, treble and bass return to zero.</p>		
<p>When changing the balance settings, the distribution setting is deselected.</p>	<p>The selection of a distribution setting imposes the balance settings. Modifying one without the other is not possible.</p>	<p>Modify the balance or distribution settings to obtain the desired musical ambience.</p>
<p>When changing a sound distribution setting, the balance setting is deselected.</p>		
<p>When I select the "All passengers" mode, the distribution is not as I would like.</p>	<p>The choice of an "All passengers" distribution can be programmed.</p>	<p>Modify the distribution setting using the slider on the touch screen.</p>

QUESTION	ANSWER	SOLUTION
<p>There is a difference in sound quality between the different audio sources.</p>	<p>For optimum sound quality, the audio settings for Volume:, Bass:, Treble:, Ambience and Loudness can be adapted to the different sound sources, which may result in audible differences when changing source.</p>	<p>Check that the audio settings for (Volume:, Bass:, Treble:, Ambience, Loudness) are adapted to the sources listened to. It is advisable to set the audio functions (Bass:, Treble:, Balance) to the middle position, select the "None" musical ambience and set the loudness correction to the "Inactive" position in radio mode.</p>
<p>With the engine off, the system switches off after a few minutes of use.</p>	<p>When the engine is switched off, the system's operating time depends on the state of charge of the battery. The switch-off is normal: the system switches to economy mode and switches off to prevent discharging of the vehicle's battery.</p>	<p>Start the vehicle's engine to increase the battery charge.</p>

Telephone

QUESTION	ANSWER	SOLUTION
I cannot connect my Bluetooth telephone.	The telephone's Bluetooth function may be switched off or the telephone may not be visible.	Check that your telephone's Bluetooth function is switched on. Check in the telephone settings that it is "Visible to all".
	The Bluetooth telephone is not compatible with the system.	You can check the compatibility of your telephone at www.peugeot.co.uk (services).
The volume of the telephone connected in Bluetooth mode is inaudible.	The volume depends both on the system and on the telephone.	Increase the volume of the audio system, to maximum if required, and increase the volume of the telephone if necessary.
	The ambient noise level has an influence on the quality of telephone communication.	Reduce the ambient noise level (close the windows, reduce the booster fan speed, slow down...).
Some contacts are duplicated in the list.	The options for synchronizing contacts are synchronizing the contacts on the SIM card, the contacts on the telephone, or both. When both synchronizations are selected, some contacts may be duplicated.	Select "Display SIM card contacts" or "Display telephone contacts".
Contacts are not shown in alphabetical order.	Some telephones offer display options. Depending on the settings chosen, contacts can be transferred in a specific order.	Modify the display setting in the telephone directory.
The system does not receive SMS text messages.	The Bluetooth mode does not permit sending SMS text messages to the system.	



MM-BTEL
SMEG+ IV2



COFETEL : RCPMASM15-1111

La operación de este equipo está sujeta a las siguientes dos condiciones: (1) es posible que este equipo o dispositivo no cause interferencia perjudicial y (2) este equipo o dispositivo debe aceptar cualquier interferencia, incluyendo la que pueda causar su operación no deseada.
The operation of this equipment is subject to the following two conditions: (1) it is possible that this equipment or device may not cause harmful interference, and (2) the equipment or device must accept any interference, including interference that may cause undesired operation.



Class A Equipment (Industrial Broadcasting & Communication Equipment).
이 기기는 업무용(A급) 전자기 적합기기(로세 판매자 또는 사용자는 이 점을 주의하시기 바라며, 가전과의 지역에서 사용하는 것을 목적으로 합니다).

MSIP -CMM-RX2-SMEGIV2

סמך אישור אלקטרוני של משרד התקשורת הוא 51-52173

אנא להחליף את האנמנת הספציפית של המכשיר, ולא לעשות בו כל שינוי טכני אחר

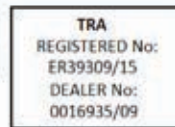

INDOTEL identification for Dominican republic

CONATEL : 2015-06-I-0000190

Aprobado CNC C-14786

INCM: 16EBP15

TRC/SS/2015/258



005-101030
AD15-0101005

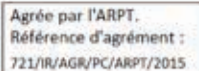

Este equipamento opera em caráter secundário, isto é, não tem direito à proteção contra interferência prejudicial, mesmo de estações do mesmo tipo e não pode causar interferência a sistemas operando em caráter primário.



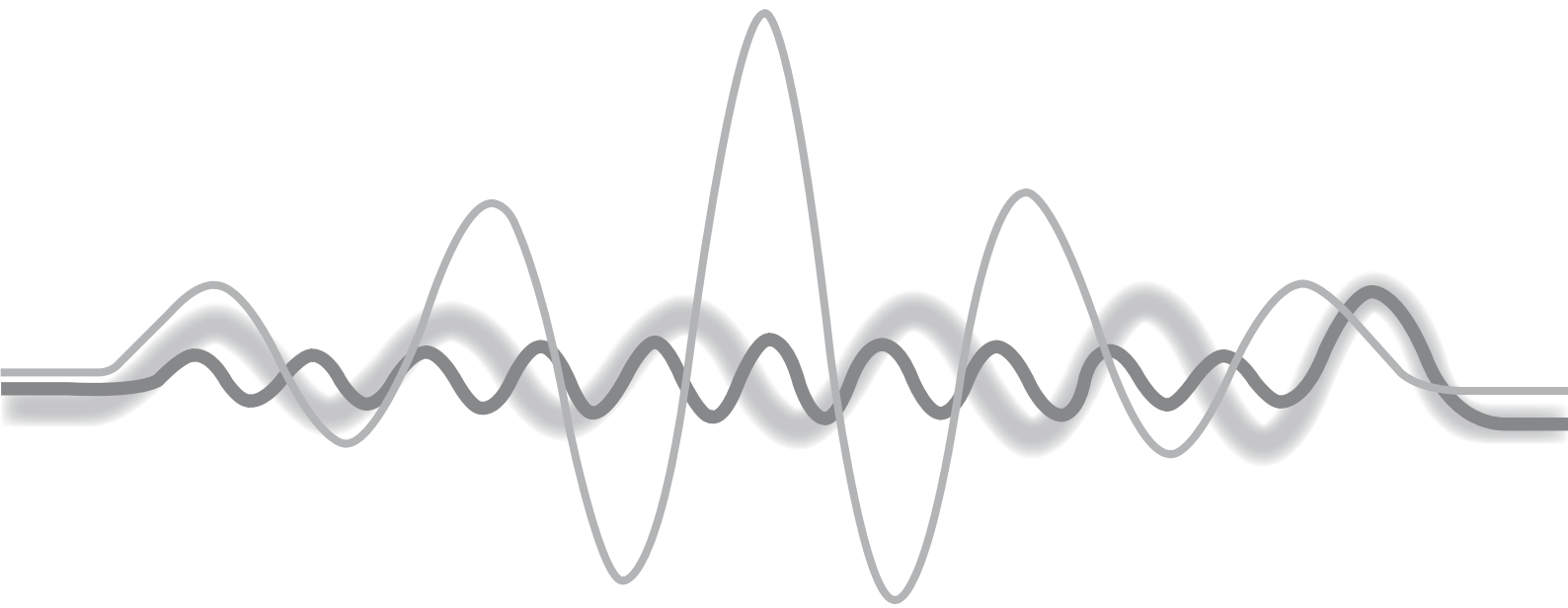

PEUGEOT Connect Sound (RD5)

Audio system / Bluetooth®



	Contents
First steps	266
Steering mounted controls	267
Menus	268
Radio	268
Media	270
Telephone	274
Screen menu map(s)	276
Frequently asked questions	280

i Your PEUGEOT Connect Sound (RD5) is coded in such a way that it will only operate in your vehicle.

! As a safety measure, the driver must only carry out operations which require prolonged attention while the vehicle is stationary. When the engine is switched off and to prevent discharging of the battery, the audio equipment may switch off after a few minutes.

First steps



On / Off, volume setting.

SOURCE

Select source:
Radio; USB; AUX; CD; Streaming.



Audio settings:
Front/rear fader, left/right balance,
bass/treble, loudness, audio
ambiances.

**LIST
REFRESH**

Display the list of local stations.
Long press: CD tracks or MP3 folders
(CD / USB).

MODE

Select the screen display mode:
Date, audio functions, trip computer,
telephone.

DARK

The DARK button changes the
screen display for improved driving
comfort at night.
1st press: upper bar only illuminated.
2nd press: black screen.
3rd press: return to standard display.



Abandon the current operation.

MENU

Display main menu.

1

Buttons 1 to 6
Select a pre-set radio station.
Long press: pre-set a station.



Automatic frequency search down/up.
Select previous/next CD, MP3 or
USB track.



Select next frequency down/up.
Select previous/next MP3 folder.
Select previous/next folder / genre /
artist / playlist (USB).

OK

Confirm.

TA / PTY

TA (Traffic Announcements) on/off.
Long press: PTY* (radio Programme
Type).



Eject CD.

**BAND
AST**

Select AM / FM wavebands.

* Available according to version.

Steering mounted controls



Radio: select the previous/next pre-set station.
 USB: select genre / artist / folder from the classification list.
 Select the previous/next item in a menu.



Radio: automatic search for a higher frequency.
 CD / MP3 / USB: select the next track.
 CD / USB: continuous press: fast forward.
 Move in the list.



Change audio source.
 Confirm a selection.
 Call/end call on the telephone.
 Press for more than 2 seconds: telephone main menu.



Radio: automatic search for a lower frequency.
 CD / MP3 / USB: select the previous track.
 CD / USB: continuous press: rewind.
 Move in the list.



Volume increase.



Volume decrease.



Mute: press the volume increase and decrease buttons simultaneously.
 The sound is restored by pressing one of the two volume buttons.

Menus

Screen C



Audio functions

Radio; CD; USB; AUX.



Trip computer

Enter distances; Alerts; State of functions.



Bluetooth®: Telephone - Audio

Pairing; Hands-free kit; Streaming.



Personalisation-configuration

Vehicle parameters; Display; Languages.

Screen A



For an overview of the menus available, refer to the "Screen menu map" section.

Radio

Selecting a station



Press the **SOURCE** button several times in succession and select the radio.



Press the **BAND AST** button to select a waveband.



Briefly press one of the buttons to carry out an automatic search of the radio stations.



Press one of the buttons to carry out a manual search up / down for radio frequencies.



Press the **LIST REFRESH** button to display the list of stations received locally (30 stations maximum). To update this list, press for more than two seconds.

RDS

i The external environment (hills, buildings, tunnels, basement car parks, ...) may block reception, including in RDS mode. This is a normal effect of the way in which radio waves are transmitted and does not indicate any failure of the audio system.

MENU

Press the **MENU** button.



Select "**Audio functions**".

OK

Press **OK**.



Select the "**FM waveband preferences**" function.

OK

Press **OK**.



Select "**Activate RDS**".

OK

Press **OK**, RDS is displayed in the screen.

In "**Radio**" mode, press **OK** directly to activate / deactivate RDS mode.



RDS, if displayed, enables you to continue listening to the same station by automatic retuning to alternative frequencies. However, in certain conditions, coverage of an RDS station may not be assured throughout the country as radio stations do not cover 100 % of the territory. This explains the loss of reception of a station that can occur during a journey.

Receiving TA messages



The TA (Traffic Announcement) function gives priority to TA alert messages. To operate, this function needs good reception of a radio station transmitting this type of message. When a traffic report is transmitted, the current audio source (Radio, CD, ...) is interrupted automatically to play the TA message. Normal playback of the audio source resumes at the end of the transmission of the message.

TA / PTY

Press the **TA** button to activate or deactivate traffic messages.

Media

USB port



This unit consists of a USB port and an auxiliary Jack socket, depending on model.

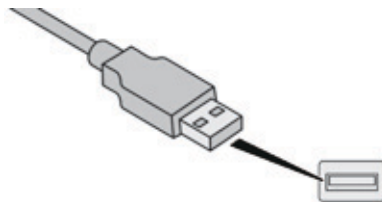

Insert a USB memory stick into the USB port or connect a USB peripheral device to the USB port using a suitable cable (not supplied).

! To protect the system, do not use a USB hub.



Press and hold **REFRESH LIST** to display the different classifications.



Select by "**Folder**" / "**Artist**" / "**Genre**" / "**Playlist**".



Press **OK** to select the classification required, then press **OK** again to confirm.



Press **REFRESH LIST** briefly to display the previously selected classification.



Navigate through the list using the left / right and up / down buttons.



Confirm the selection by pressing **OK**.



Press one of these buttons to gain access to the previous / next track in the list. Press and hold one of the buttons for fast forward or rewind.



Press one of these buttons to gain access to the previous / next "**Folder**" / "**Artist**" / "**Genre**" / "**Playlist**" in the list.

Auxiliary socket (AUX)



Connect the portable device (MP3 player, ...) to the auxiliary Jack socket using an audio cable (not supplied).

Press the **SOURCE** button several times in succession and select **AUX**.

First adjust the volume on your portable device (to a high level). Then adjust the volume on your audio system. Operation of controls is via the portable device.

! Do not connect a device to both the Jack auxiliary socket and the USB port at the same time.

CD player

Insert circular compact discs only. Some anti-pirating systems, on original discs or CDs copied using a personal recorder, may cause faults which are no reflection on the quality of the vehicle's player. Insert a CD in the player, play begins automatically.

SOURCE

To play a disc which has already been inserted, press the **SOURCE** button several times in succession and select **CD**.



Press one of the buttons to select a track on the CD.

**LIST
REFRESH**

Press the **LIST REFRESH** button to display the list of tracks on the CD.



Press and hold one of the buttons for fast forward or rewind.

Playing an MP3 CD compilation

Insert an MP3 CD compilation in the player. The audio equipment searches for all of the music tracks, which may take anything between a few seconds and several tens of seconds, before play begins.

! On a single disc, the CD player can read up to 255 MP3 files spread over 8 folder levels. However, it is advisable to keep to a limit of two levels to reduce the access time before the CD is played.

While the CD is being played, the folder structure is not followed. All of the files are displayed on a single level.

SOURCE

To play a disc which has already been inserted, press the **SOURCE** button several times in succession and select **CD**.



Press one of the buttons to select a folder on the CD.



Press one of the buttons to select a track on the CD.

LIST REFRESH

Press the **LIST REFRESH** button to display the list of directories of the MP3 compilation.



Press and hold one of the buttons for fast forward or rewind play.

Information and advice

The audio system will only play files with the extension ".mp3" with a sampling rate of 22.05 KHz or 44.1 KHz. No other type of file (.wma, .mp4, .m3u, etc.) can be played.

It is advisable to restrict file names to 20 characters without using special characters (e.g. " ? ; ù) to avoid any playing or displaying problems.

In order to be able to play a recorded CDR or CDRW, when recording, the ISO 9660 level 1. 2 or Joliet file format is recommended. If the disc is recorded in another format, it may not be played correctly.

It is recommended that the same recording format is always used for an individual disc, with as low a speed as possible (4x maximum) for optimum sound quality.

In the particular case of a multi-session CD, the Joliet format is recommended.

Use only USB memory sticks formatted FAT32 (File Allocation Table).

! To protect the system, do not use a USB hub.

i It is recommended that you use genuine Apple® USB cables for correct operation.

Bluetooth® audio streaming

Streaming allows music files on the telephone to be played via the audio system.

Connect the telephone: see the "**Telephone**" section.

Select in the "**Bluetooth: Telephone - Audio**" menu the telephone to be connected. The audio system connects to a newly paired telephone automatically.

SOURCE Activate the streaming source by pressing the **SOURCE*** button.

Control of tracks to be played is via the buttons on the audio system control panel and the steering mounted controls**. The contextual information can be displayed in the screen.

* In certain cases, play of the audio files must be initiated from the keypad.

** If the telephone supports the function.

Connecting Apple® players

Connect the Apple® player to the USB port using a suitable cable (not supplied). Play starts automatically.

Control is via the audio system.

The classifications available are those of the portable device connected (artists / albums / genres / playlists / audiobooks / podcasts).

The version of software in the audio system may not be compatible with the generation of your Apple® player.

Telephone

Pairing a Bluetooth® telephone

Screen C

(Available according to model and version)

! As a safety measure and because they require prolonged attention on the part of the driver, the operations for pairing of the Bluetooth® mobile telephone with the Bluetooth® hands-free system of your audio equipment must be carried out with the vehicle stationary and the ignition on.

Go to www.peugeot.co.uk for more information (compatibility, more help, ...).

Activate the telephone's Bluetooth® function and ensure that it is "visible to all" (telephone configuration).

Press the **MENU** button.



In the menu, select:

- "Bluetooth: Telephone - Audio"
- "Bluetooth configuration"
- "Perform a Bluetooth search"

A window is displayed with a message that a search is in progress.

i The services available depend on the network, the SIM card and the compatibility of the Bluetooth® device used. Consult your telephone's manual and your operator to find out which services are available to you.

The first 4 telephones recognised are displayed in this window.

The "**Telephone**" menu permits access to the following functions in particular: "**Directory**"*, "**Calls list**", "**Consult the paired equipment**".

* If your telephone is fully compatible.

Select the telephone to be connected from the list. Only one telephone can be connected at a time.



A virtual keypad is displayed in the screen: enter a code with at least 4 digits.



Confirm by pressing **OK**.

A message in the screen indicates the telephone chosen. To accept the pairing, enter the same code on the telephone, then confirm with **OK**. If pairing fails, the number of attempts is not limited.

A message that the pairing has been successful appears in the screen.

The automatic connection authorised is only active after the telephone has been configured. The directory and the call list can be accessed after the necessary synchronisation period.

Receiving a call

An incoming call is announced by a ring and a superimposed display in the screen.



Select the **YES** tab on the display using the buttons.

OK

Confirm by pressing **OK**.



Press this button at the steering mounted controls to accept the call.

Making a call

From the "**Bluetooth: Telephone - Audio**" menu.

Select "**Manage the telephone call**".

Select "**Call**".

Or

Select "**Calls list**".

Or

Select "**Directory**".



Press this button for more than two seconds for access to your directory, then navigate using the thumbwheel.

Or

To dial a number, use your telephone's keypad, with the vehicle stationary.

Ending a call



During a call, press this button for more than 2 seconds.

Confirm with **OK** to end the call.

i The system accesses the telephone's contacts directory, depending on its compatibility, and while it is connected by Bluetooth®.

i With certain telephones connected by Bluetooth® you can send a contact to the directory of the audio system. Contacts imported in this way are saved in a permanent directory visible to all, whatever the telephone connected. The menu for the directory is not accessible if it is empty.

Screen menu map(s)

Screen A

1 Radio-CD

2 RDS options

2 REG mode

2 CD repeat

2 Shuffle play

1 Vehicle config*

2 R wiper in rev

2 Guide lighting

1 Options

2 Diagnostic

3 View

3 Abandon

1 Units

2 Temperature: °Celsius / °Fahrenheit

2 Fuel consumption: KM/L - L/100 - MPG

1 Display adjust

2 Year

2 Month

2 Day

2 Hour

2 Minutes

2 12 H/24 H mode

1 Language

2 Français

2 Italiano

2 Nederlands

2 Português

2 Português do Brasil

2 Deutsch

2 English

2 Español

2 Čeština

2 Hrvatski

2 Magyar

* The settings vary according to the trim level of the vehicle.

Screen C

OK

Press the **OK** dial for access to short-cut menus according to the display on the screen.

Radio

- 1** activate / deactivate RDS
- 1** activate / deactivate REG mode
- 1** activate / deactivate radiotext

CD / MP3 CD

- 1** activate / deactivate Intro
- 1** activate / deactivate track repeat
(the entire current CD for CD, the entire current folder for MP3 CD)
- 1** activate / deactivate random play
(the entire current CD for CD, the entire current folder for MP3 CD)

USB

- 1** activate / deactivate track repeat
(of the current folder / artist / genre / playlist)
- 1** activate / deactivate random play
(of the current folder / artist / genre / playlist)

Screen C

Pressing the **MENU** button displays:

MENU



Audio functions

- 1 **Audio functions**
- 2 **FM preferences**
 - 3 Alternative frequencies (RDS)
 - 4 Activate / deactivate
 - 3 Regional mode (REG)
 - 4 Activate / deactivate
 - 3 Radio-text information (RDTXT)
 - 4 Activate / deactivate

- 2 **Play modes**
 - 3 Album repeat (RPT)
 - 4 Activate / deactivate
 - 3 Track random play (RDM)
 - 4 Activate / deactivate



Trip computer

- 1 **Enter distance to destination**
- 2 Distance: x miles
- 1 **Warning log**
- 2 **Vehicle diagnosis**
- 1 **State of systems**
- 2 **Systems activated or deactivated**



Personalisation-configuration

1 **Define the vehicle parameters***

1 **Display configuration**

2 **Brightness-video adjustment**

3 Normal video

3 Inverse video

3 Brightness (- +) adjustment

2 **Date and time adjustment**

3 Setting the day/month/year

3 Setting the hour/minute

3 Choice of 12 h / 24 h mode

2 **Choice of units**

3 l/100 km - mpg - km/l

3 °Celsius / °Fahrenheit

1 **Choice of language**



Bluetooth: Telephone - Audio

1 **Bluetooth configuration**

2 **Connect/Disconnect an equipment**

2 **Telephone function**

2 **Audio Streaming function**

3 Consult the paired equipment

3 Delete a paired equipment

3 Perform a Bluetooth search

1 **Call**

2 **Calls list**

3 Directory

1 **Manage the telephone call**

2 **Terminate the current call**

2 **Activate secret mode**

* The settings vary according to vehicle.

Frequently asked questions

The table below gives answers to the most frequently asked questions on your audio system.

QUESTION	ANSWER	SOLUTION
With the engine off, the audio system switches off after a few minutes of use.	When the engine is switched off, the audio system operating time depends on the state of charge of the battery. The switch-off is normal: the audio equipment switches to economy mode and switches off to prevent discharging of the vehicle's battery.	Start the vehicle's engine to increase the battery charge.
The message "the audio system is overheated" appears on the display.	In order to protect the installation if the surrounding temperature is too high, the audio system switches to an automatic thermal protection mode leading to a reduction in volume or CD play stopping.	Switch the audio system off for a few minutes to allow the system to cool.

Radio

QUESTION	ANSWER	SOLUTION
There is a difference in sound quality between the different audio sources (radio, CD...).	For optimum sound quality, the audio settings (Volume, Bass, Treble, Ambience, Loudness) can be adapted to the different sound sources, which may result in audible differences when changing source (radio, CD...).	Check that the audio settings (Volume, Bass, Treble, Ambience, Loudness) are adapted to the sources listened to. It is advisable to set the audio functions (Bass, Treble, Front-Rear Balance, Left-Right Balance) to the middle position, select the musical ambience "None" and set the loudness correction to the "Active" position in CD mode or to the "Inactive" position in radio mode.

QUESTION	ANSWER	SOLUTION
The stored stations do not function (no sound, 87.5 Mhz is displayed...).	An incorrect waveband is selected.	Press the BAND AST button to return to the waveband (AM, FM1, FM2, FMAST) on which the stations are stored.
The traffic announcement (TA) is displayed. I do not receive any traffic information.	The radio station is not part of the regional traffic information network.	Tune to a radio station which broadcasts traffic information.
The quality of reception of the radio station listened to gradually deteriorates or the stored stations do not function (no sound, 87.5 Mhz is displayed...).	The vehicle is too far from the transmitter used by the station listened to or there is no transmitter in the geographical area through which the vehicle is travelling.	Activate the RDS function to enable the system to check whether there is a more powerful transmitter in the geographical area.
	The environment (hills, buildings, tunnels, underground car parks...) block reception, including in RDS mode.	This phenomenon is normal and does not indicate a failure of the audio equipment.
	The aerial is absent or has been damaged (for example when going through an automatic car wash or into an underground car park).	Have the aerial checked by a PEUGEOT dealer.
Sound cut-outs of 1 to 2 seconds in radio mode.	During this brief sound cut-out, the RDS searches for another frequency giving better reception of the station.	Deactivate the RDS function if the phenomenon is too frequent and always on the same route.

Media

QUESTION	ANSWER	SOLUTION
The message "USB peripheral error" is displayed on the screen. The Bluetooth® connection is cut.	The battery of the peripheral may not be sufficiently charged.	Recharge the battery of the peripheral device.
	The USB memory stick is not recognised. The USB memory stick may be corrupt.	Reformat the USB memory stick.
The CD is ejected automatically or is not played by the player.	The CD is inserted upside down, is unplayable, does not contain any audio data or contains an audio format which the player cannot play. The CD is protected by an anti-pirating protection system which is not recognised by the audio equipment.	<ul style="list-style-type: none"> - Check that the CD is inserted in the player the right way up. - Check the condition of the CD: the CD cannot be played if it is too damaged. - Check the content in the case of a recorded CD: consult the advice in the "Audio" section. - The audio equipment's CD player does not play DVDs. - Due to their quality level, certain writeable CDs will not be played by the audio system.
The CD player sound is poor.	The CD used is scratched or of poor quality.	Insert good quality CDs and store them in suitable conditions.
	The audio equipment settings (bass, treble, ambiances) are unsuitable.	Set the treble or bass level to 0, without selecting an ambience.

Telephone

QUESTION	ANSWER	SOLUTION
I am unable to access my voicemail.	Few telephones or service providers allow the use of this function.	

Emergency or assistance call

For Russia, Belarus and Kazakhstan.



PEUGEOT Connect SOS

SOS In an emergency, press this button for more than 2 seconds. Flashing of the green LED and a voice message confirm that the call has been made to the "PEUGEOT Connect SOS" call centre*.

Pressing this button again immediately cancels the request.

The green LED goes off.

The green LED remains on (without flashing) when communication is established.

It goes off at the end of the call.

"PEUGEOT Connect SOS" immediately locates your vehicle, starts communication with you in your language**, and where necessary sends the appropriate public emergency services**. In countries where the service is not available, or when the locating service has been expressly declined, the call is sent directly to the emergency services (112) without the vehicle location.

! If an impact is detected by the airbag control unit, and independently of the deployment of any airbags, an emergency call is made automatically.

i If you benefit from the PEUGEOT Connect Packs offer with the SOS and assistance pack included, there are additional services available to you in your personal space, via the Internet website for your country.

* Subject to the general conditions for the service available from dealers and subject to technological and technical limitations.

** Depending on the geographical cover of "PEUGEOT Connect SOS", "PEUGEOT Connect Assistance" and the official national language selected by the owner of the vehicle.
The list of countries covered and PEUGEOT CONNECT services is available from dealers or on the website for your country.

Operation of the system

For Russia, Belarus and Kazakhstan.



When the ignition is switched on, the green LED comes on for 3 seconds indicating that the system is operating correctly.



The red indicator lamp is on continuously: there is a system fault.

The red indicator lamp flashes: replace the back-up battery.

In either case, the emergency and assistance calls may not function.

Contact a qualified repairer as soon as possible.

i A fault with the system does not prevent the vehicle being driven.

PEUGEOT Connect Assistance



Press this button for more than 2 seconds to request assistance if the vehicle breaks down.

A voice message confirms that the call has been made**.

Pressing this button again immediately cancels the request.

The cancellation is confirmed by a voice message.

Geo-location



You can deactivate geo-location by simultaneously pressing the "PEUGEOT Connect SOS" and "PEUGEOT Connect Assistance" buttons, followed by a press on "PEUGEOT Connect Assistance" to confirm.

To reactivate geo-location, simultaneously press the "PEUGEOT Connect SOS" and "PEUGEOT Connect Assistance" buttons again, followed by a press on "PEUGEOT Connect Assistance" to confirm.

i If you purchased your vehicle outside the Brand's dealer network, we invite you to have a dealer check the configuration of these services and, if desired, modified to suit your wishes. In a multi-lingual country, configuration is possible in the official national language of your choice.

i For technical reasons and in particular to improve the quality of "PEUGEOT CONNECT services" services to customers, the manufacturer reserves the right to carry out updates to the vehicle's on-board telematic system.

** Depending on the geographical cover of "PEUGEOT Connect SOS", "PEUGEOT Connect Assistance" and the official national language selected by the owner of the vehicle. The list of countries covered and PEUGEOT CONNECT services is available from dealers or on the website for your country.

Reproduction or translation of all or part of this document is prohibited without written authorisation from Automobiles PEUGEOT.

Automobiles PEUGEOT declares, by application of the provisions of the European legislation (Directive 2000/53) relating to End of Life Vehicles, that it achieves the objectives set by this legislation and that recycled materials are used in the manufacture of the products that it sells.

Printed in the EU
Anglais
08-16



PEUGEOT

AUTOMOBILES PEUGEOT - Siège Social : 75, avenue de la Grande-Armée 75016 Paris - France
Tél. : +33 (0)1 40 66 55 11 - Fax : +33 (0)1 40 66 54 14 - Téléc : 645 700 F
<http://www.peugeot.com>

Société anonyme au capital de 172.711.770 € - R.C.S. : 552 144 503 R.C.S. Paris - SIRET : 552 144 503 00018 - APE : 2910Z

